

GROWING GOURMET  
and  
MEDICINAL MUSHROOMS

食用及び薬用きのこの栽培

a companion guide to  
*The Mushroom Cultivator*

by

Paul Stamets

*Growing Gourmet & Medicinal Mushrooms* is terrific. It solidifies Paul Stamets' reputation as a mycological trailblazer. It is practical, comprehensive as well as inspirational—an absolute must for anyone who wants to grow their own mushrooms. . . .

David Arora, author *Mushrooms Demystified* and *All That the Rain Promises and More*.

Stamets draws on the collective experience of centuries of mushroom cultivation, creating a revolutionary model for the use of higher fungi. Not only does it cover every aspect of cultivation, he also addresses the issues of environmentalism, health and business. For anyone who has ever wanted to grow mushrooms, this is “The Book”.

Alan E. Bessette, Ph.D. , Utica College of Syracuse University, NY.

*Growing Gourmet & Medicinal Mushrooms* is the most comprehensive treatment of the subject I have seen in my 30 years as a mycologist and mushroom specialist. It is an absolute must for the day-to-day activities of professional mushroom growers and an extremely valuable resource for amateur growers, agricultural extension personnel, researchers, teachers, students, marketers, and anyone with an interest in mushroom culture and its practical applications. I heartily recommend this book to mushroom aficionados everywhere.

S. C. Jong, Ph.D., The American Type Culture Collection, Rockville, MD.

*Growing Gourmet & Medicinal Mushrooms* is the best and most comprehensive guide to growing mushrooms ever published. But *Growing Gourmet & Medicinal Mushrooms* is much more than a grower's manual: it is a visionary quest—and Paul Stamets is your best possible guide—not just for informing you about growing mushrooms, but for transforming you into a myco-warrior, an active participant in a heroic, Gaian process of planetary healing through mushroom cultivation. *Growing Gourmet & Medicinal Mushrooms* is a sacred text for spiritual growth—an instruction manual for all those seeking a happier and healthier way of life. . .

Gary Lincoff, author, *The Audubon Field Guide to Mushrooms*, the New York Botanical Garden, N.Y.C.

Paul Stamets is the most successful cultivator of a wide range of exotic mushrooms known to me. In this latest book he brings together history, folklore, scientific facts and his own extensive first hand experience—all presented in an entertaining and informative format. As with the earlier *Mushroom Cultivator*, *Growing Gourmet & Medicinal Mushrooms* will certainly become a standard reference.

Scott Redhead, Ph.D., Dept. of Botany University of Washington, Seattle, WA.

*Growing Gourmet & Medicinal Mushrooms* is the most comprehensive and exciting book on the subject to be published. I hope it will make many of these useful species more available to more people throughout the world, because I believe these mushrooms can enrich our lives as well as improve our health.

Andrew T. Weil, M.D., author, *Health and Healing* and *The Natural Mind*.

This book should help advance the cause of mycology, and mushroom biology worldwide. It will be an important reference for those who are interested in research as well as in the cultivation of mushrooms. *Growing Gourmet & Medicinal Mushrooms* is unique not only in its treatment of the technical aspects of growing gourmet and medicinal mushrooms, but also in its emphasis on the environmental importance of mushrooms in terms of world biological diversity.

S. T. Chang, Ph.D, Dept. of Biology, The Chinese University of Hong Kong

*Growing Gourmet & Medicinal Mushrooms* is an extremely informative text on all aspects of the mushroom growing industry and provides us with the expertise of the author who has been cultivating mushrooms for over 20 years. This book adds to the extensive knowledge of the author's previous book, *The Mushroom Cultivator*, and thus will undoubtedly become a standard for those who would like to enter this field. It is written clearly, organized efficiently, and exhibits the love and enjoyment the author has for his chosen profession. It is a welcome addition to mycology in general.

David Largent, Ph.D, Humboldt State University, CA.

For both the commercial grower and the amateur, *Growing Gourmet & Medicinal Mushrooms* is a very complete approach to the subject and I highly recommend it.

Orson K. Miller, Jr., Ph.D, Biology Dept., Virginia State University, VA.

This book, a true labor of love, makes a major contribution to our knowledge of the practical production of gourmet and medicinal mushrooms.

Dan Royse, Ph.D, Penn State College of Agricultural Sciences, University Park, PA.

This book should be on the library shelves of everyone interested in the cultivation of fleshy fungi. . . . It is a mine of information and will be a source book for a good long time.

Roy Watling, Ph.D, Senior Principal Scientific Officer, Royal Botanic Garden, Edinburgh, U. K.

Pick up this book and prepare to be swept away into the world of mushroom cultivation on the tide of Paul's contagious enthusiasm. He presents a wealth of ideas and detailed instructions for the cultivation of mushrooms in a book that is destined to join the ranks of mycological classics. Doers and dreamers, students and teachers will all find something to enjoy in this book.

Nancy Smith Weber, Ph.D, Forest Sciences Dept., Oregon State University, OR.

Copyright © 1993 Paul Stamets. All rights reserved. No part of this book may be reproduced or transmitted in any form by any means without written permission from the publisher, except by a reviewer, who may quote brief passages in a review.

Published and distributed by:

Ten Speed Press  
P.O. Box 7123,  
Berkeley, CA 94707

ISBN: 0-89815-608-4

Printed in Hong Kong

Co-produced by Ten Speed Press and  
Mycomedia™

a division of Fungi Perfecti  
P.O. Box 7634,  
Olympia, WA 98507

Typeset by Graphics Unlimited, Eugene, Oregon

Designed by Betsy Bodine Ford and Paul Stamets.

The author invites comments on *Growing Gourmet & Medicinal Mushrooms* as well as personal experiences concerning mushroom cultivation.

Address all mail to Mycomedia™ Productions.

# *mycotopia*

*an environment wherein  
ecological equilibrium  
is enhanced through the  
judicious use of fungi*



# *Dedication*

*To my family  
and the warriors  
of Hwa Rang Do*

---

# Table of Contents

<b>1. Mushrooms, Civilization and History</b> .....	<b>1</b>
<b>2. The Role of Mushrooms in Nature</b> .....	<b>5</b>
The Mycorrhizal Gourmet Mushrooms: Matsutake, Boletus, Chanterelles & Truffles .....	5
Parasitic Mushrooms: Blights of the Forest .....	9
Saprophytic Mushrooms: The Decomposers .....	10
The Global Environmental Shift and The Loss of Species Diversity .....	13
Catastrophobia: Nature as a Substrate Supplier .....	14
Mushrooms and Toxic Wastes .....	14
Mushroom Mycelium and Mycofiltration .....	15
<b>3. Selecting a Candidate for Cultivation</b> .....	<b>17</b>
Woodland Mushrooms .....	18
Grassland Mushrooms .....	18
Dung Inhabiting Mushrooms .....	19
Compost/ Litter/Disturbed Habitat Mushrooms .....	19
<b>4. Natural Culture: Creating Mycological Landscapes</b> .....	<b>21</b>
Some Wild Mushrooms Naturally Found in Beds of Wood Chips .....	23
Methods of Mushroom Cultivation .....	24
Spore Mass Inoculation .....	24
Transplantation: Mining Mycelium from Wild Patches .....	26
Inoculating Outdoor Substrates with Pure Cultured Spawn .....	26
When to Inoculate an Outdoor Mushroom Patch .....	30
Site Location of a Mushroom Patch .....	30
Stumps as Platforms for Growing Mushrooms .....	31
Log Culture .....	34
<b>5. The Stametsian Model: Permaculture with a Mycological Twist</b> .....	<b>41</b>
<b>6. Materials for Formulating a Fruiting Substrate</b> .....	<b>47</b>
Raw Materials .....	48
Suitable Wood Types: Candidate Tree Species .....	48
List of Suitable Tree Species for the Cultivation of Gourmet & Medicinal Mushrooms .....	50
Cereal Straws .....	53
Corncobs and Cornstalks .....	54
Coffee and Banana Plants .....	54

---

Soybean Waste .....	55
Supplements .....	55
Structure of the Habitat .....	56
<b>7. Biological Efficiency: An Expression of Yield .....</b>	<b>57</b>
<b>8. Home-made vs. Commercial Spawn .....</b>	<b>61</b>
<b>9. The Mushroom Life Cycle .....</b>	<b>65</b>
<b>10. The Six Vectors of Contamination .....</b>	<b>75</b>
<b>11. Mind and Methods for Mushroom Culture .....</b>	<b>83</b>
Overview of Techniques for Cultivating Mushrooms .....	85
<b>12. Culturing Mushroom Mycelium on Agar Media .....</b>	<b>89</b>
Preparing Nutrified Agar Media .....	89
Malt Extract, Yeast Agar .....	90
Potato, Dextrose, Yeast Agar .....	90
Oatmeal, Malt, Yeast Enriched Agar .....	90
Dog Food Agar .....	90
Corn Meal, Yeast, Glucose Agar .....	90
Nitrogen & Carbohydrate Supplements .....	91
End-Substrate Supplements .....	92
Pouring Agar Media .....	92
Starting a Mushroom Strain by Cloning .....	93
Cloning Wild Specimens vs. Cloning Cultivated Mushrooms .....	96
How to Collect Spores .....	96
Germinating Spores .....	100
Purifying a Culture .....	101
<b>13. The Stock Culture Library: A Genetic Bank of Mushroom Strains.....</b>	<b>103</b>
Preserving the Culture Library .....	104
The Stamets "P" Value System for Age Determination of a Strain .....	106
Iconic Types of Mushroom Mycelium .....	108
The Event of Volunteer Primordia on Nutrified Agar Media .....	115
<b>14. Evaluating a Mushroom Strain .....</b>	<b>117</b>
28 Features for Evaluating and Selecting a Mushroom Strain .....	118
<b>15. Generating Grain Spawn .....</b>	<b>127</b>
Formulas for Creating Grain Spawn .....	129
Grain Formulas for Spawn Production .....	130
First Generation Grain-Spawn Masters .....	133
Steps for Generating Grain Spawn Masters .....	134
Second and Third Generation Grain Spawn .....	135

---



---

Steps for Creating Second and Third Generation Grain Spawn .....	136
Autoclavable Spawn Bags .....	139
Liquid Inoculation Techniques .....	142
Spore Mass Inoculation .....	142
Liquid Inoculation Techniques: Mycelial Fragmentation and Fermentation .....	146
Pelletized (Granular) Spawn .....	151
Matching the Spawn with the Substrate: Critical Choices on the Mycelial Path .....	152
Spawn Storage .....	153
<b>16. Creating Sawdust Spawn .....</b>	<b>155</b>
Step-by-Step Instructions for Inoculating Sawdust .....	156
<b>17. Growing Gourmet Mushrooms on Enriched Sawdust .....</b>	<b>161</b>
The Supplemented Sawdust "Fruiting" Formula: Creating the Production Block .....	162
Testing For Moisture Content .....	164
Choosing a Sterilizer, a.k.a the Retort or Autoclave .....	165
Sterilization of Supplemented Substrates .....	167
Post-Autoclaving .....	170
Unloading the Autoclave .....	170
Atmospheric Steam Sterilization of Sawdust Substrates .....	171
Inoculation of Supplemented Sawdust: Creating the Production Block .....	173
Incubation of the Production Blocks .....	176
Achieving Full Colonization on Supplemented Sawdust .....	177
Handling the Bags Post Full Colonization .....	179
<b>18. Cultivating Gourmet Mushrooms on Agricultural Waste Products .....</b>	<b>181</b>
Alternative Fruiting Formulas .....	182
Heat Treating the Bulk Substrate .....	183
Alternative Methods for Rendering Straw & other Bulk Substrates for Mushroom Cultivation .....	189
<b>19. Cropping Containers .....</b>	<b>191</b>
Tray Culture .....	192
Vertical Wall Culture .....	195
Slanted Wall or "A" Frame Culture .....	196
Bag Culture .....	196
Column Culture .....	198
Bottle Culture .....	204
<b>20. Casing: A Topsoil Promoting Mushroom Formation .....</b>	<b>209</b>
<b>21. Growth Parameters for Gourmet and Medicinal Mushroom Species ...</b>	<b>211</b>
Spawn Run: Colonizing the Substrate .....	212
Primordia Formation: The Initiation Strategy .....	213

---

Fruitbody (Mushroom) Development ..... 217

**The Gilled Mushrooms ..... 219**

    The Black Poplar Mushroom of the Genus *Agrocybe* ..... 220

*Agrocybe aegerita*

    The Shaggy Mane of the Genus *Coprinus* ..... 224

*Coprinus comatus*

    The Enoki Mushroom ..... 229

*Flammulina velutipes*

    The Clustered Wood-lovers ..... 236

*Hypoloma capnoides*, Brown Gilled Woodlover ..... 237

*Hypoloma sublateritium*, Kuritake (The Chestnut Mushroom) ..... 242

    The Beech Mushrooms ..... 246

*Hypsizygus tessulatus*, Buna-Shimeji ..... 247

*Hypsizygus ulmarius*, Shirotamogitake ..... 254

    The Shiitake Mushroom ..... 259

*Lentinula edodes*

    The Nameko Mushroom ..... 277

*Pholiota nameko*

    The Oyster Mushrooms ..... 283

*Pleurotus citrinopileatus*, The Golden Oyster Mushroom ..... 285

*Pleurotus cystidiosus*, The Abalone Mushroom ..... 292

*Pleurotus djamor*, The Pink Oyster Mushroom ..... 297

*Pleurotus eryngii*, The King Oyster Mushroom ..... 304

*Pleurotus euosmus*, The Tarragon Oyster Mushroom ..... 309

*Pleurotus ostreatus*, The Tree Oyster Mushroom ..... 313

*Pleurotus pulmonarius* "*P. sajor-caju*", The Phoenix or Indian Oyster Mushroom ..... 321

    The Caramel Capped Psilocybes ..... 327

*Psilocybe cyanescens* complex

    The King Stropharia of the Genus *Stropharia* ..... 335

*Stropharia rugoso-annulata*

    The Paddy Straw Mushroom of the Genus *Volvariella* ..... 343

*Volvariella volvacea*

**The Polypore Mushrooms of the Genera *Ganoderma*, *Grifola* and *Polyporus* ..... 351**

*Ganoderma lucidum*, Reishi or Ling Chi ..... 355

*Grifola frondosa*, Maitake or Hen-of-the-Woods ..... 370

*Polyporus umbellatus*, Zhu Ling or the Umbrella Polypore ..... 380

**The Lion's Mane of the Genus *Hericium* ..... 387**

*Hericium erinaceus*, Lion's Mane

**The Wood Ears of the Genus *Auricularia* ..... 395**

*Auricularia polytricha*

**The Morels: Land-Fish Mushrooms of the Genus *Morchella* ..... 401**

    The Morel Life Cycle ..... 404

    The Development of Indoor Morel Cultivation ..... 405



<i>Morchella angusticeps</i> and allies: The Black Morels .....	409
<b>22. Maximizing the Substrate’s Potential through Species Sequencing .....</b>	<b>419</b>
<b>23. Harvesting, Storing, and Packaging the Crop for Market .....</b>	<b>423</b>
Harvesting the Crop .....	424
Packaging and Storing the Crop for Market .....	426
Drying Mushrooms .....	427
Marketing the Product .....	429
<b>24. Mushroom Recipes: Enjoying the Fruits of Your Labors .....</b>	<b>431</b>
<b>25. Cultivation Problems &amp; Their Solutions: A Troubleshooting Guide .....</b>	<b>443</b>

## Appendices

<b>I. Descriptions of Environments for A Mushroom Farm .....</b>	<b>455</b>
The Laboratory Complex .....	455
The Growing Room Complex .....	456
Environment 1: The Growing Rooms .....	456
Environment 2: The Spawning Room .....	456
Environment 3: The Pasteurization Chamber or Phase II Room .....	457
Environment 4: The Main Corridor: A Highway for Substrate & Product Flow .....	458
Environment 5: Sorting, Grading & Packing Room .....	458
Environment 6: The Refrigeration Room .....	458
Environment 7: Shipping & Receiving Room .....	459
Environment 8: Production/Recapture Open-Air Growing Room .....	459
<b>II. Designing and Building A Spawn Laboratory .....</b>	<b>461</b>
Design Criteria for A Spawn Laboratory .....	464
Good Clean Room Habits: Helpful Suggestions for Minimizing Contamination in the Laboratory .....	467
<b>III. The Growing Room: An Environment for Mushroom Formation &amp; Development .....</b>	<b>469</b>
Design Criteria for the Growing Rooms .....	470
Managing the Growing Rooms: Good Habits for the Personnel .....	478
<b>IV. Resource Directory .....</b>	<b>481</b>
Recommended Mushroom Field Guides .....	481
Mushroom Book Suppliers .....	483
Annual Mushroom Festivals & Events .....	483
Mushroom Cultivation Seminars & Training Centers .....	485
Mushroom Study Tours/Adventures .....	485
International Mushroom Associations .....	486
North American Mushroom Societies & Associations .....	486

---

Mushroom Growers Associations .....	490
Sources for Mushroom Cultures .....	491
Sources for Mushroom Spawn .....	492
Grower's Associations & Sources for Marketing Information .....	493
Mushroom Newsletters & Journals .....	494
Mushroom Museums .....	495
Sources for Medicinal Mushroom Products .....	495
Mycological Resources on the Internet .....	495
<b>V. Analyses of Basic Materials Used in Substrate Preparation.....</b>	<b>497</b>
<b>VI. Data Conversion Tables .....</b>	<b>513</b>
Weights & Volumes .....	514
Temperature .....	515
Heat Energy .....	516
Light .....	516
Pressure & Power .....	516
Miscellaneous Data .....	517
<b>Glossary .....</b>	<b>519</b>
<b>Bibliography .....</b>	<b>527</b>
<b>Acknowledgments .....</b>	<b>544</b>

---

# Foreword

Mushrooms—fleshy fungi—are the premier recyclers on the planet. Fungi are essential to recycling organic wastes and the efficient return of nutrients back into the ecosystem. Not only are they recognized for their importance within the environment, but also for their effect on human evolution and health. Yet, to date, the inherent biological power embodied within the mycelial network of mushrooms largely remains a vast, untapped resource. As we enter the 21st century, ecologists, foresters, bioremediators, pharmacologists, and mushroom growers are uniting at a new frontier of knowledge, where enormous biodynamic forces are at play.

Only in the last half of this century have we learned enough about the cultivation of mushrooms to tap into their inherent biological power. Working with mushroom mycelium *en masse* will empower every country, farm, recycling center and individual with direct economic, ecological and medical benefits. As we approach a new century, this myco-technology is a perfect example of the equation of good environmentalism, good health and good business.

This book strives to create new models for the future use of higher fungi in the environment. As woodland habitats, especially old growth forests, are lost to development, mushroom diversity also declines. Wilderness habitats still offer vast genetic resources for new strains. The temperate forests of North America, particularly the mycologically rich Pacific Northwest, may well be viewed in the 21st century as the Amazon Basin was viewed by pharmaceutical companies earlier in the 20th century. Hence, mushroom cultivators should preserve this gene pool now for its incalculable future value. The importance of many mushroom species may not be recognized for decades to come.

In many ways, this book is an off-spring of the marriage of many cultures—arising from the worldwide use of mushrooms as food, as religious sacraments in Mesoamerica, and as medicine in Asia. We now benefit from the collective experience of lifetimes of mushroom cultivation. As cultivators we must continue to share, explore and expand the horizons of the human/fungal relationship. Humans and mushrooms must bond in an evolutionary partnership. By empowering legions of individuals with the skills of mushroom tissue culture, future generations will be able to better manage our resources and improve life on this planet.

Now that the medical community widely recognizes the health-stimulating properties of mushrooms, a combined market for gourmet *and* medicinal foods is rapidly emerging. People with compromised immune systems would be wise to create their own medicinal mushroom gardens. A community-based, resource-driven industry, utilizing recyclable materials in a fashion that strengthens ecological equilibrium and human health will evolve. As recycling centers flourish, their by-products include streams of organic waste which cultivators can divert into mushroom production.

I foresee a network of environmentally sensitive and imaginative individuals presiding over this new industry, which has previously been controlled by a few mega-businesses. The decentralization began with *The Mushroom Cultivator* in 1983. It now continues with *Growing Gourmet & Medicinal Mushrooms*. Join me in the next phase of this continuing revolution.

---

# Introduction

Mushrooms have never ceased to amaze me. The more I study them, the more I realize how little I have known, and how much more there is to learn. For thousands of years, fungi have evoked a host of responses from people—from fear and loathing to reverent adulation. And I am no exception.

When I was a little boy, wild mushrooms were looked upon with foreboding. It was not as if my parents were afraid of them, but our Irish heritage lacked a tradition of teaching children anything nice about mushrooms. In this peculiar climate of ignorance, rains fell and mushrooms magically sprang forth, wilted in the sun, rotted and vanished without a trace. Given the scare stories told about “experts” dying after eating wild mushrooms, my family gave me the best advice they could: Stay away from all mushrooms, except those bought in the store. Naturally rebellious, I took this admonition as a challenge, a call to arms, firing up an already over-active imagination in a boy hungry for excitement.

When we were 7, my twin brother and I made a startling mycological discovery—*Puffballs!* We were told that they were not poisonous, but if the spores got into your eyes, you would be instantly blinded! This information was quickly put to good use. We would viciously assault each other with mature puffballs which would burst upon impact and emit a cloud of brown spores. The battle would continue until all the puffballs in sight had been hurled. They provided us with hours of delight over the years. Neither one of us ever went blind—although we both suffer from very poor eyesight. You must realize that to a 7 year-old these free, ready-made missiles satisfied instincts for warfare on the most primal of levels. This is my earliest memory of mushrooms, and to this day I consider it to be a positive emotional experience. (Although I admit a psychiatrist might like to explore these feelings in greater detail.)

Not until I became a teenager did my hunter-gatherer instincts resurface, when a relative returned from extensive travels in South America. With a twinkle in his eyes, he spoke of his experiences with the sacred *Psilocybe* mushrooms. I immediately set out to find these species, not in the jungles of Colombia, but in fields and forests of Washington State where they were rumored to grow. For the first several years, my searches provided me with an abundance of excellent edible species, but no *Psilocybes*. Nevertheless, I was hooked.

When hiking through the mountains, I encountered *so* many mushrooms. They were a mystery until I could match them with descriptions in a field guide. I soon came to learn that a mushroom was described as “edible,” “poisonous,” or my favorite: “unknown,” based on the experiences of others like me, who boldly ingested them. People are rarely neutral in their opinion about mushrooms—either they *love* them or they *hate* them. I took delight in striking fear into the hearts of the latter group whose illogical distrust of fungi provoked my over-active imagination.

When I enrolled in the Evergreen State College in 1975, my skills at mushroom identification earned the support of a professor with similar interests. My initial interest was taxonomy, and I soon focused on fungal microscopy. The scanning electron microscope revealed new worlds, dimensional landscapes I never dreamed possible. As my interest grew, the need for fresh material year-round

---

became essential. Naturally, these needs were aptly met by learning cultivation techniques, first in petri dishes, then on grain, and eventually on a wide variety of materials. In the quest for fresh specimens, I had embarked upon an irrevocable path that would steer my life on its current odyssey.



Paul Stamets in his laboratory. (Photograph by John Stamets.)

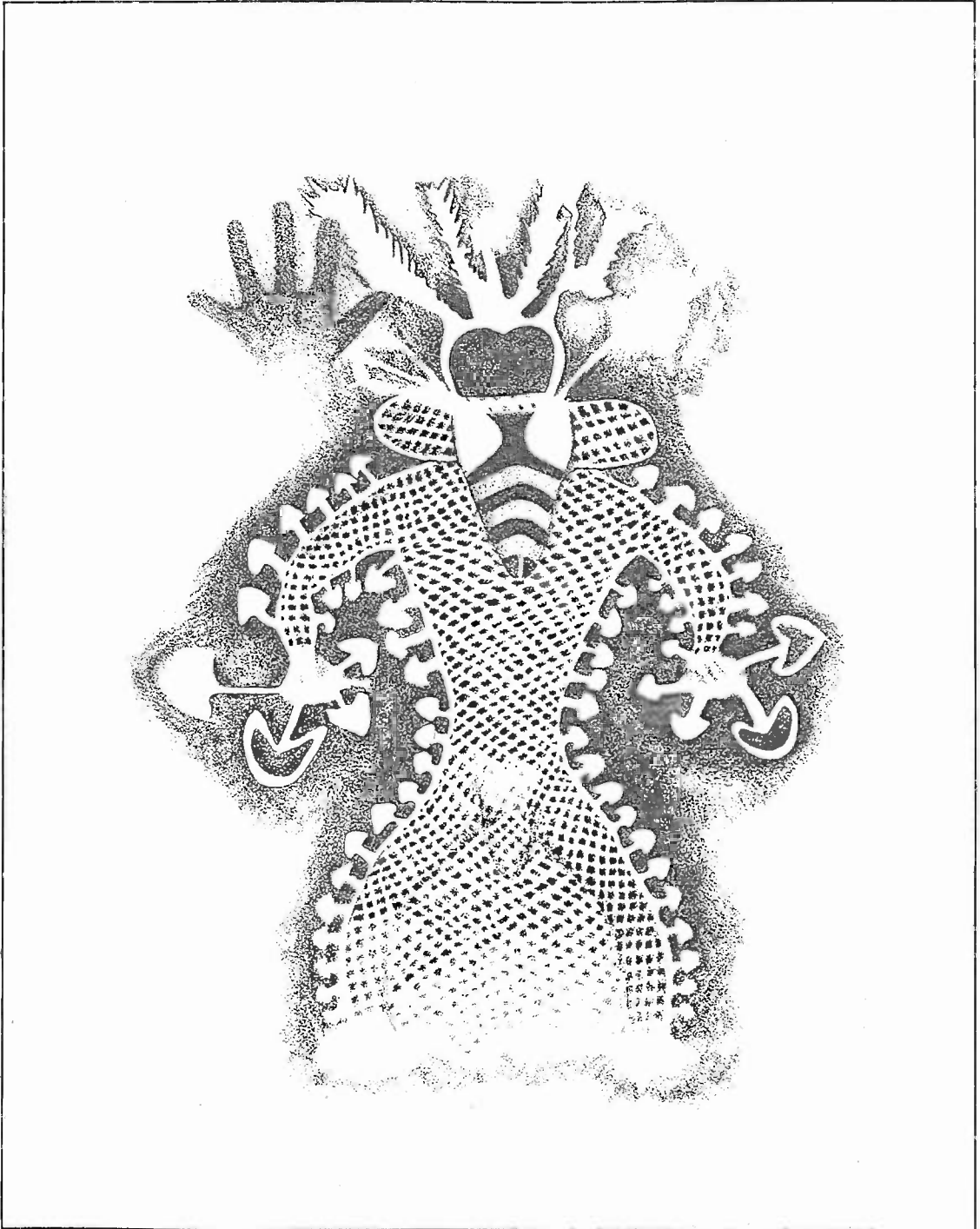

Figure 1. Tassili Cave Art from Northern Algeria, circa 5000 years B.C.



# Mushrooms, Civilization & History

**H**umanity's use of mushrooms extends back to Paleolithic times. Few people—even anthropologists—comprehend how influential mushrooms have been in affecting the course of human evolution. Mushrooms have played pivotal roles in ancient Greece, India and Mesoamerica. True to their beguiling nature, fungi have always elicited deep emotional responses: from adulation by those who understand them to outright fear by those who do not.

The historical record reveals that mushrooms have been used for less than benign purposes. Claudius II and Pope Clement VII were both killed by enemies who poisoned them with deadly *Amanitas*. Buddha died, according to legend, from a mushroom that grew underground. Buddha was given the mushroom by a peasant who believed it to be a delicacy. In ancient verse, that mushroom was linked to the phrase “pig’s foot” but has never been identified. (Although truffles grow underground and pigs are used to find them, no deadly poisonous species are known.)



Figure 2. Cruz Stamets holding a Mesoamerican Mushroom Stone, circa 500 B.C.

The oldest archaeological record of mushroom use is probably a Tassili image from a cave dating back 5000 years B. C. (Figure 1). The artist's intent is clear. Mushrooms with electrified auras are depicted outlining a dancing shaman. The spiritual interpretation of this image transcends time and is obvious. No wonder that the word "bemushroomed" has evolved to reflect the devout mushroom lover's state of mind.

In the spring of 1991, hikers in the Italian Alps came across the well-preserved remains of a man who died over 5300 years ago, approximately 1700 years later than the Tassili cave artist. Dubbed the "Iceman" by the news media, he was well-equipped with a knapsack, flint axe, a string of dried Birch Polypores (*Piptoporus betulinus*) and another as yet unidentified mushroom. The polypores can be used as tinder for starting fires and as medi-

cine for treating wounds. Further, a rich tea with immuno-enhancing properties can be prepared by boiling these mushrooms. Equipped for traversing the wilderness, this intrepid adventurer had discovered the value of the noble polypores. Even today, this knowledge can be life-saving for anyone astray in the wilderness.

Fear of mushroom poisoning pervades every culture, sometimes reaching phobic extremes. The term *mycophobic* describes those individuals and cultures where fungi are looked upon with fear and loathing. Mycophobic cultures are epitomized by the English and Irish. In contrast, *mycophilic* societies can be found throughout Asia and eastern Europe, especially amongst Polish, Russian and Italian peoples. These societies have enjoyed a long history of mushroom use, with as many as a hundred common names to describe the mushroom varieties they loved.

The use of mushrooms by diverse cultures was intensively studied by an investment banker named R. Gordon Wasson. His studies concentrated on the use of mushrooms by Mesoamerican, Russian, English and Indian cultures. With the French mycologist, Dr. Roger Heim, Wasson published research on *Psilocybe* mushrooms in Mesoamerica, and on *Amanita* mushrooms in Euro-Asia/Siberia. Wasson's studies spanned a lifetime marked by a passionate love for fungi. His publications include: *Mushrooms, Russia, & History*; *The Wondrous Mushroom: Mycolatry in Mesoamerica*; *Maria Sabina and her Mazatec Mushroom Velada*; and *Persephone's Quest: Entheogens and the Origins of Religion*. More than any individual of the 20th century, Wasson kindled interest in ethnomycology to its present state of intense study. Wasson died on Christmas Day in 1986.

One of Wasson's most provocative findings can be found in *Soma: Divine Mushroom of*

*Immortality* (1976) where he postulated that the mysterious SOMA in the Vedic literature, a red fruit leading to spontaneous enlightenment for those who ingested it, was actually a mushroom. The Vedic symbolism carefully disguised its true identity: *Amanita muscaria*, the hallucinogenic Fly Agaric. Many cultures portray *Amanita muscaria* as the archetypal mushroom. Although some Vedic scholars disagree with his interpretation, Wasson's exhaustive research still stands. (See Brough (1971) and Wasson (1972)).

Aristotle, Plato, Homer, and Sophocles all participated in religious ceremonies at Eleusis where an unusual temple honored Demeter, the Goddess of Earth. For over two millennia, thousands of pilgrims journeyed fourteen miles from Athens to Eleusis, paying the equivalent of a month's wage for the privilege of attending the annual ceremony. The pilgrims were ritually harassed on their journey to the temple,

apparently in good humor.

Upon arriving at the temple, they gathered in the initiation hall, a great telestrion. Inside the temple, pilgrims sat in rows that descended step-wise to a hidden, central chamber from which a fungal concoction was served. An odd feature was an array of columns, beyond any apparent structural need, whose designed purpose escapes archaeologists. The pilgrims spent the night together and reportedly came away forever changed. In this pavilion crowded with pillars, ceremonies occurred, known by historians as the Eleusinian Mysteries. No revelation of the ceremony's secrets could be mentioned under the punishment of imprisonment or death. These ceremonies continued until repressed in the early centuries of the Christian era.

In 1977, at a mushroom conference on the Olympic Peninsula, R. Gordon Wasson, Albert

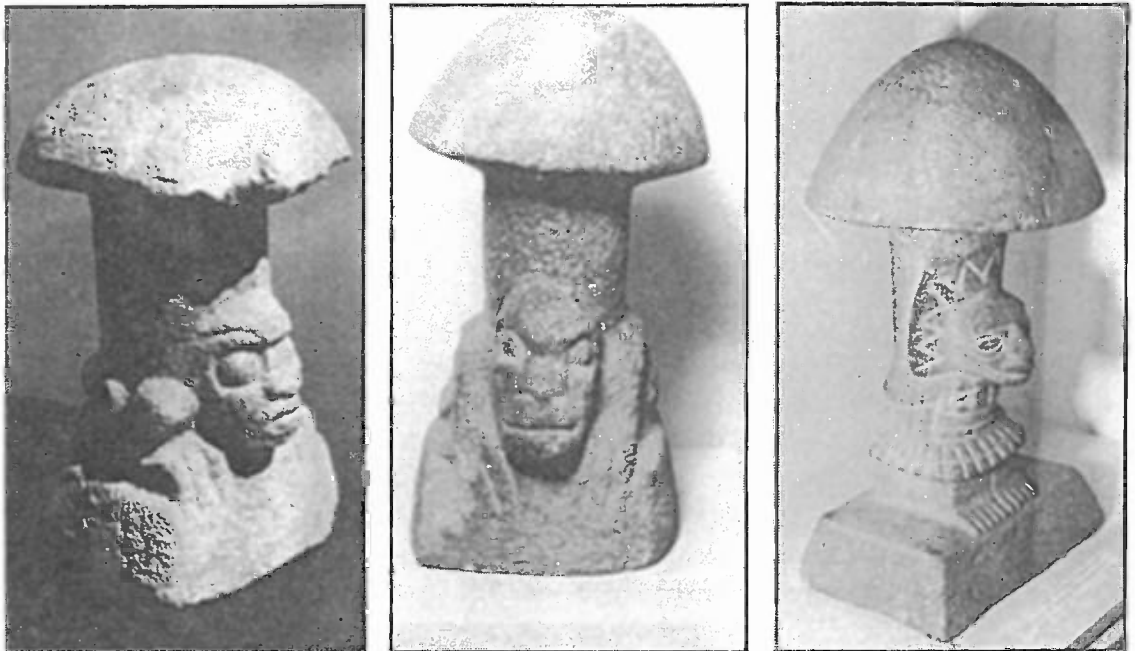

Figures 3, 4, 5. Meso-American mushroom stones, circa 300 years B.C., from the Pacific slope of Guatemala.

Hofmann, and Carl Ruck first postulated that the Eleusinian mysteries centered on the use of psychoactive fungi. Their papers were later published in a book entitled *The Road to Eleusis: Unveiling the Secret of the Mysteries* (1978). That Aristotle and other founders of

western philosophy undertook such intellectual adventures, and that this secret ceremony persisted for nearly 2000 years, underscores the profound impact that fungal rites have had on the evolution of western consciousness.

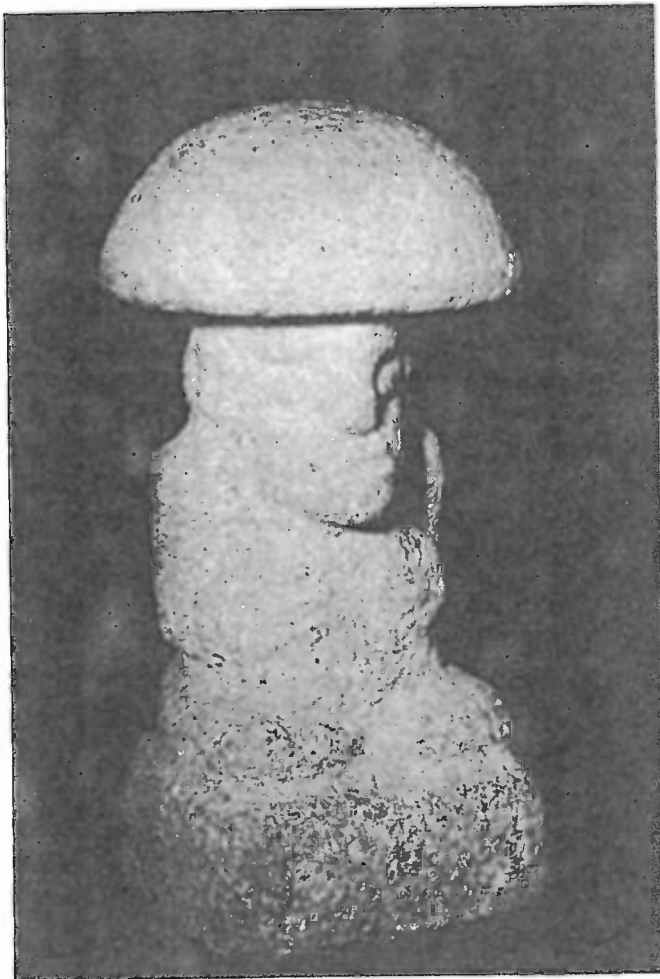

Figure 6. Pre-Classic Mayan Mushroom Stone from Kaminaljuyu Highlands of Guatemala, circa 500 years B.C.

---

# The Role of Mushrooms in Nature

**E**cologically, mushrooms can be classified into three groups: the *saprophytes*, the *parasites* and the *mycorrhizae*. Although this book centers on the cultivation of gourmet and medicinal saprophytic species, other mushrooms are also discussed.

## The Mycorrhizal Gourmet Mushrooms: Matsutake, Boletus, Chanterelles & Truffles

Mycorrhizal mushrooms form a mutually dependent, beneficial relationship with the roots of host plants, ranging from trees to grasses. “Myco” means mushrooms while “rhizal” means roots. The filaments of cells which grow into the mushroom body are called the *mycelium*. The mycelia of mycorrhizal mushrooms can form an exterior sheath covering the roots of plants and are called *ectomycorrhizal*. Or they can invade the interior root cells of host plants and these are called *endomycorrhizal*. In either case, both organisms benefit from this association. Plant growth is accelerated.

The resident mushroom mycelium increases the plant's absorption of nutrients, nitrogenous compounds, and essential elements (phosphorus, copper and zinc). By growing beyond the immediate root zone, the mycelium channels and concentrates nutrients from afar. Plants with mycorrhizal fungal partners can also resist diseases far better than those without.

Most ecologists now recognize that a forest's health is directly related to the presence, abundance and variety of mycorrhizal associations. The mycelial component of top soil within a typical Douglas fir forest in the Pacific Northwest approaches 10% of the total biomass. Even this estimate may be low, not taking into account the mass of the endomycorrhizae and the many yeast-like fungi that thrive in the topsoil.

The nuances of climate, soil chemistry and predominant microflora play determinate roles in the cultivation of mycorrhizal mushrooms in natural settings. I am much more inclined to spend time attempting the cultivation of native mycorrhizal species than to import exotic candidates from afar. Here is a relevant example.

Truffle orchards are well established in France, Spain and Italy, with the renowned Perigold black truffle, *Tuber melanosporum*, fetching up to \$500 per lb. (See Figure 7). Only in the past 30 years has tissue culture of Truffle mycelium become widely practiced, allowing the development of planted Truffle orchards. Land owners seeking an economic return without resorting to cutting trees are naturally attracted to this prospective investment. The idea is enticing. Think of having an orchard of oaks or filberts, yielding pounds of Truffles per year for decades at several hundred dollars a pound! Several



Figure 7. A Truffle market in France.

companies in this country have, in the past 12 years, marketed Truffle-inoculated trees for commercial use. Calcareous soils (i. e. high in calcium) in Texas, Washington and Oregon have been suggested as ideal sites. Tens of thousands of dollars have been exhausted in this endeavor. Ten years after planting, I know of only one, possibly two, successes with this method. This discouraging state of affairs should be fair warning to investors seeking profitable enterprises in the arena of Truffle cultivation. Suffice it to say that the only ones to have made money in the Truffle tree industry are those who have resold "inoculated" seedlings to other would-be trufflateurs.

A group of Oregon trufflateurs has been attempting to grow the Oregon White Truffle, *Tuber gibbosum*. Douglas fir seedlings have been inoculated with mycelium from this na-

tive species and planted in plots similar to Christmas tree farms. Several years passed before the harvests began. However, since Oregon White Truffles were naturally occurring nearby, whether or not the inoculation process actually caused the truffles to form is unclear.

Mycorrhizal mushrooms in Europe have suffered a radical decline in years of late while the saprophytic mushrooms have increased in numbers. The combined effects of acid rain and other industrial pollutants, even the disaster at Chernobyl, have been suggested to explain the sudden decline of both the quantity and diversity of wild mycorrhizal mushrooms. Most mycologists believe the sudden availability of dead wood is responsible for the comparative increase in the numbers of saprophytic mushrooms. The decline in Europe portends, in a worst case

scenario, a total ecological collapse of the mycorrhizal community. In the past ten years, the diversity of the mycorrhizal mushrooms in Europe has fallen by more than 50%! Some species, such as the Chanterelle, have all but disappeared from regions in the Netherlands, where it was abundant only 20 years ago. (See Arnolds, 1992; Leck, 1991). Many biologists view these mushrooms as indicator species, the first domino to fall in a series leading to the failure of the forest's life-support systems.

One method for inoculating mycorrhizae calls for the planting of young seedlings near the root zones of proven mushroom-producing trees. The new seedlings acclimate and become "infected" with the mycorrhizae of a neighboring, parent tree. In this fashion, a second generation of trees carrying the mycorrhizal fungus is generated. After a few



Figure 8. Scanning electron micrograph of an emerging root tip being mycorrhized by mushroom mycelium.

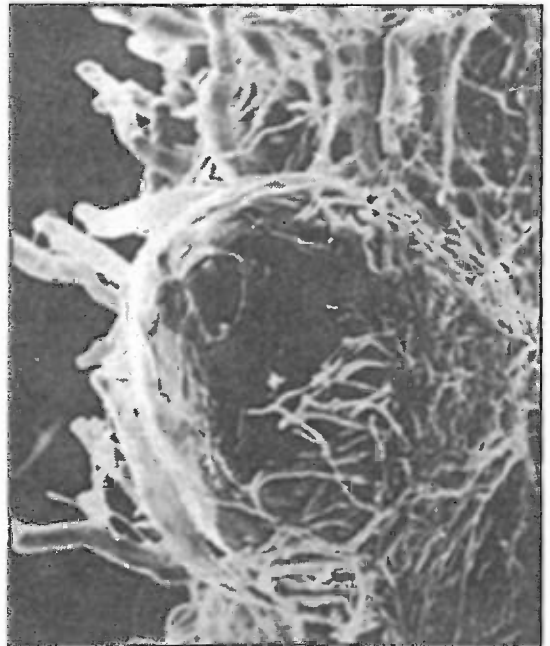

Figure 9. Scanning electron micrograph of mycelium encasing the root of a tree after mycorrhization.

years, the new trees are dug up and replanted into new environments. This method has had the longest tradition of success in Europe.

Another approach, modestly successful, is to dip the exposed roots of seedlings into water enriched with the spore mass of a mycorrhizal candidate. First, mushrooms are gathered from the wild and soaked in water. Thousands of spores are washed off of the gills resulting in an enriched broth of inoculum. A spore-mass slurry coming from several mature mushrooms and diluted into a 5-gallon bucket can inoculate a hundred or more seedlings. The concept is wonderfully simple. Unfortunately, success is not guaranteed.

Broadcasting spore mass onto the root zones of likely candidates is another avenue that costs little in time and effort. Habitats should be selected on the basis of their parallels in nature. For instance, Chanterelles can be found in oak forests of the midwest and in Douglas fir forests of the west. Casting spore mass of Chanterelles into forests similar to those where Chanterelles proliferate is obviously the best choice. Although the success rate is not high, the rewards are well worth the minimum effort involved. Bear in mind that tree roots confirmed to be mycorrhized with a gourmet mushroom will not necessarily result in harvestable mushrooms. Fungi and their host trees may have long associations without the appearance of edible fruitbodies. (For more information, consult Fox (1983)).

On sterilized media, most mycorrhizal mushrooms grow slowly, compared to the saprophytic mushrooms. Their long evolved dependence on root by-products and complex soils makes media preparation inherently more complicated. Some mycorrhizal species, like *Pisolithus tinctorius*, a puffball

favoring pines, grow quite readily on sterilized media. A major industry has evolved providing foresters with seedlings inoculated with this fungus. Mycorrhized seedlings are healthier and grow faster than non-mycorrhized ones. Unfortunately, the gourmet mycorrhizal mushroom species do not fall into the readily cultured species category. The famous Matsutake (*Tricholoma magnivelare*) may take weeks before its mycelium fully colonizes the medium on a single petri dish! Unfortunately, this rate of growth is the rule rather than the exception with the majority of gourmet mycorrhizal species.

Chanterelles are one of the most popularly collected wild mushrooms. In the Pacific Northwest of North America the harvesting of Chanterelles has become a controversial, multi-million dollar business. Like Matsutake, Chanterelles (*Cantharellus cibarius*) also form mycorrhizal associations with trees. Additionally, they demonstrate a unique interdependence on soil yeasts. This type of mycorrhizal relationship makes tissue culture most difficult. At least three organisms must be cultured simultaneously: the host tree, the mushroom, and soil yeasts. A red soil yeast, *Rhodotorula glutinis*, is crucial in stimulating spore germination. The Chanterelle life cycle may have more dimensions of biological complexity. Currently, no one has grown Chanterelles to the fruitbody stage under laboratory conditions. Not only do other microorganisms play essential roles, the timing of their introduction appears critical to success in the mycorrhizal theater.

Senescence occurs with both saprophytic and mycorrhizal mushroom species. Often the first sign of senescence is not the inability of mycelium to grow vegetatively, but the loss of the formation of the sexually repro-

---



ducing organ: the mushroom. Furthermore, the slowness from sowing the mycelium to the final stages of harvest confounds the quick feed-back all cultivators need to refine their techniques. Thus, experiments trying to mimic how Chanterelles or Matsutake grow may take 20-40 years each, the age the trees must be to support healthy, fruiting colonies of these prized fungi. Faster methods are clearly desirable, but presently only the natural model has shown any clue to success.

Given the huge hurdle of time for honing laboratory techniques, I favor the "low-tech" approach of planting trees adjacent to known producers of Chanterelles, Matsutake, Truffles and Boletes. After several years, the trees can be uprooted, inspected for mycorrhizae, and replanted in new environments. The value of the contributing forest can then be viewed, not in terms of board feet of lumber, but in terms of its ability for creating satellite, mushroom/tree colonies. When industrial or suburban development threatens entire forests, and is unavoidable, future-oriented foresters may consider the removal of the mycorrhizae as a last-ditch effort to salvage as many mycological communities as possible by simple transplantation techniques, although on a much grander scale.

Until laboratory techniques evolve to establish a proven track record of successful marriages that result in harvestable crops, I hesitate to recommend mycorrhizal mushroom cultivation as an economic endeavor. Mycorrhizal cultivation pales in comparison to the predictability of growing saprophytic mushrooms like Oyster and Shiitake. The industry simply needs the benefit of many more years of mycological research to better decipher the complex models of mycorrhizal mushrooms.



Figure 10. Oyster and Honey Mushrooms growing on a stump.

## Parasitic Mushrooms: Blights of the Forest?

Parasitic fungi have been the bane of foresters. They do immeasurable damage to the health of resident tree species, but in the process, create new habitats for many other organisms. Although the ecological damage caused by parasitic fungi is well understood, we are only just learning of their importance in the forest ecosystem. Comparatively few mushrooms are true parasites.

Parasites live off a host plant, endangering the host's health as it grows. Of all the parasitic mushrooms that are edible, the Honey Mushrooms, *Armillaria mellea*, are the best known. One of these Honey Mushrooms, known as *Armillaria bulbosa*, made national headlines when scientists reported finding a single colony covering 37 acres, weighing at least 220,000 lbs. with an estimated age of 1500 years! With the exception of the trembling Aspen forests of Colorado, this fungus is the largest-known, living organism on the planet. And, it is a marauding parasite!

In the past, a parasitic fungus has been looked upon as being biologically evil. This



Figure 11. Intrepid amateur mycologist Richard Gaines points to a parasitic fungus attacking Yew

view is rapidly changing as science progresses. A new parasitic fungus attacking the Yew tree has been recently discovered by Montana State University researchers. This new species is called *Taxomyces andreanae* for one notable feature: it produces minute quantities of the potent anti-carcinogen taxol, a proven shrinker of breast cancer. (Stone, 1993). If this new fungus can be grown in sufficient quantities in liquid culture, the potential value of the genome of parasitic fungi takes on an entirely new dimension.

Many saprophytic fungi can be weakly parasitic in their behavior, especially if a host tree is dying from other causes. These can be called *facultative* parasites: saprophytic fungi activated by favorable conditions to behave parasitically. Some parasitic fungi continue to grow long after their host has died. Oyster

mushrooms (*Pleurotus ostreatus*) are classic saprophytes, although they are frequently found on dying cottonwood, oak, poplar, birch, maple and alder trees. These appear to be operating parasitically when they are only exploiting a rapidly evolving ecological niche.

Many parasitic fungi are microfungi and are barely visible to the naked eye. In mass, they cause the formation of cankers and shoot blights. Often their preeminence in a middle-aged forest is symptomatic of other imbalances within the ecosystem. Acid rain, ground water pollution, insect damage, and loss of protective habitat all are contributing factors unleashing parasitic fungi. After a tree dies, from parasitic fungi or other causes, saprophytic fungi come into play.

## Saprophytic Mushrooms: The Decomposers

Most of the gourmet mushrooms are saprophytic, wood-decomposing fungi. These saprophytic fungi are the premier recyclers on the planet. The filamentous mycelial network is designed to weave between and through the cell walls of plants. The enzymes and acids they secrete degrade large molecular complexes into simpler compounds. All ecosystems depend upon fungi's ability to decompose organic plant matter soon after it is rendered available. The end result of their activity is the return of carbon, hydrogen, nitrogen and minerals back into the ecosystem in forms usable to plants, insects and other organisms. As decomposers, they can be separated into three key groups. Some mushroom species cross over from one category to another depending upon prevailing conditions.

**Primary Decomposers:** These are the

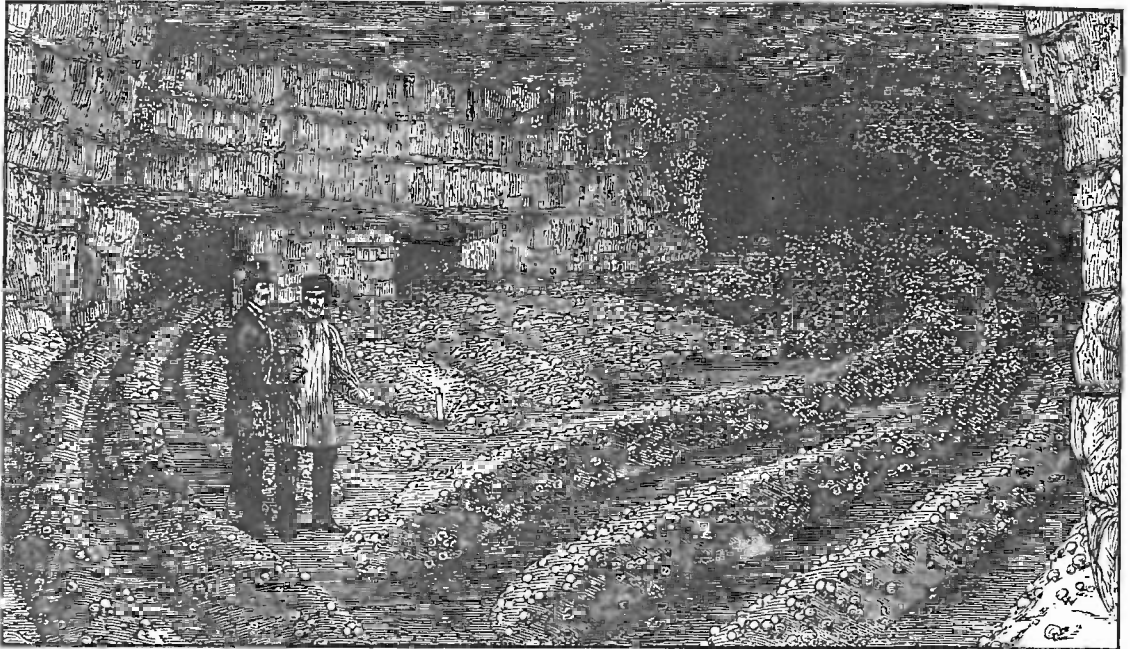

Figure 12. The cultivation of the Button Mushroom, a secondary decomposer, in caves near Paris in July of 1868. Note candle used for illumination. (From Robinson's *Mushroom Culture*, 1885, David Mc Kay Publishers, Philadelphia).

fungi first to capture a twig, a blade of grass, a chip of wood, a log or stump. Primary decomposers are typically fast-growing, sending out ropey strands of mycelium that quickly attach to and decompose plant tissue. Most of the decomposers degrade wood. Hence, the majority of these saprophytes are woodland species, such as Oyster mushrooms (*Pleurotus* species), Shiitake (*Lentinula edodes*) and King Stropharia (*Stropharia rugoso-annulata*). However, each species has developed specific sets of enzymes to break down lignin-cellulose, the structural components of most plant cells. Once the enzymes of one mushroom species have broken down the lignin-cellulose to its fullest potential, other saprophytes utilizing their own repertoire of enzymes can reduce this material even further.

**Secondary Decomposers:** These mushrooms rely on the previous activity of other fungi to partially break down a substrate to a state wherein they can thrive. Secondary decomposers typically grow from composted material. The actions of other fungi, actinomycetes, bacteria and yeasts all operate within a compost. As plant residue is degraded by these microorganisms, the mass, structure and composition of the compost is reduced. Heat, carbon dioxide, ammonia and other gases are emitted as by-products of the composting process. Once these microorganisms (especially actinomycetes) have completed their life cycles, the compost is susceptible to invasion by a select secondary decomposer. A classic example of a secondary decomposer is the White Button Mushroom, *Agaricus brunnescens*, the most

commonly cultivated mushroom.\* Another example is *Stropharia ambigua* which invades outdoor mushroom beds after wood chips have been first decomposed by a primary saprophyte.

**Tertiary Decomposers:** An amorphous group, the fungi represented by this group are typically soil dwellers. They survive in habitats that are years in the making from the activity of the primary and secondary decomposers. Fungi existing in these reduced substrates are remarkable in that the habitat appears inhospitable for most other mushrooms. A classic example of a tertiary decomposer is *Aleuria aurantia*, the Orange Peel Mushroom. This complex group of fungi often pose unique problems to would-be cultivators. *Panaeolus subbalteatus* is yet another example. Although one can grow it on composted substrates, this mushroom has the reputation of growing prolifically in the discarded compost from Button mushroom farms. Other tertiary decomposers include species of *Conocybe*, *Agrocybe*, *Pluteus* and some *Agaricus* species.

The floor of a forest is constantly being replenished by new organic matter. Primary, secondary and tertiary decomposers can all occupy the same location. In the complex environment of the forest floor, a "habitat" can actually be described as the overlaying of several habitats mixed into one. And, over time, as each habitat is being transformed, successions of mushrooms occur. This model becomes infinitely complex when taking into account the

inter-relationships of not only the fungi to one another, but the fungi to other micro-organisms (yeasts, bacteria, protozoa), plants, insects and mammals.

Primary and secondary decomposers afford the most opportunities for cultivation. To select the best species for cultivation, several variables must be carefully matched.

Climate, available raw materials, and the mushroom strains all must interplay for cultivation to result in success. Native species are the best choices when you are designing outdoor mushroom landscapes.

Temperature-tolerant varieties of mushrooms are more forgiving and easier to grow than those which thrive within finite temperature limits. In warmer climates, moisture is typically more rapidly lost, narrowing the opportunity for mushroom growth. Obviously, growing mushrooms outdoors in a desert climate is more difficult than growing mushrooms in moist environments where they naturally abound. Clearly, the site selection of the mushroom habitat is crucial. The more exposed a habitat is to direct mid-day sun, the more difficult it is for mushrooms to flourish.

Many mushrooms actually benefit from indirect sunlight, especially in the northern latitudes. Pacific Northwest mushroom hunters have long noted that mushrooms grow most prolifically, not in the darkest depths of a woodlands, but in environments where shade and dappled sunlight are combined. Sensitivity studies to light have established that various species differ in their optimal response to wave-bands of sunlight. Nevertheless, few mushrooms enjoy prolonged exposure to direct sunlight.

---

\* The cultivation of this mushroom is covered in detail in *The Mushroom Cultivator* (1983) by Stamets & Chilton.

## The Global Environmental Shift and The Loss of Species Diversity

Studies in Europe show a frightening loss of species diversity in forestlands, most evident with the mycorrhizal species. Many mycologists fear many mushroom varieties, and even species, will soon become extinct. As the mycorrhizal species decline in both numbers and variety, the populations of saprophytic and parasitic fungi initially rise, a direct result of the increased availability of dead wood debris. However, as woodlots are burned and replanted, the complex mosaic of the natural forest is replaced by a highly uniform, mono-species landscape. Because the replanted trees are nearly identical in age, the cycle of debris replenishing the forest floor is interrupted. This new "ecosystem" cannot support the myriad of fungi, insects, small mammals, birds, mosses and flora so characteristic of ancestral forests. In pursuit of commercial forests, the native ecology has been supplanted by a biologically anemic woodlot. This woodlot landscape is barren in terms of species diversity.

With the loss of every ecological niche, the sphere of bio-diversity shrinks. At some presently unknown level, the diversity will fall below the critical mass needed for sustaining a healthy forestland. Once passed, the forest may not ever recover without direct and drastic counter-action: the insertion of multi-age trees, of different species, with varying canopies and undergrowth. Even with such extraordinary action, the complexity of a replanted forest can not match that which has evolved for thousands of years. Little is understood about prerequisite microflora—yeasts,

bacteria, micro-fungi—upon which the ancient forests are dependent. As the number of species declines, whole communities of organisms disappear. New associations are likewise limited. If this trend continues, I believe the future of new forests, indeed the planet, is threatened.

Apart from the impact of wood harvest, the health of biologically diverse forests is in increasing jeopardy due to acid rain and other airborne toxins. Eventually, the populations of all fungi—saprophytic and mycorrhizal—suffer as the critical mass of dead trees declines more rapidly than it is replenished. North Americans have already experienced the results of habitat-loss from the European forests. Importation of wild picked mushrooms from Mexico, United States and Canada to Europe has escalated radically in the past twenty years. This increase in demand is not just due to the growing popularity of eating wild mushrooms. It is a direct reflection of the decreased availability of wild mushrooms from regions of the world suffering from ecological shock. The woodlands of North America are only a few decades behind the forests of Europe and Asia.

With the loss of habitat of the mycorrhizal gourmet mushrooms, market demands for gourmet mushrooms should shift to those that can be cultivated. Thus, the pressure on this not-yet renewable resource would be alleviated, and the judicious use of saprophytic fungi by homeowners as well as foresters may well prevent widespread parasitic disease vectors. Selecting and controlling the types of saprophytic fungi occupying these ecological niches can benefit both forester and forestland.

## Catastrophia: Nature as a Substrate Supplier

Many saprophytic fungi benefit from catastrophic events in the forests. When hurricane-force winds rage across woodlands, enormous masses of dead debris are generated. The older trees are especially likely to fall. Once the higher canopy is gone, the growth of the younger, lower canopy of trees is triggered by the suddenly available sunlight. The continued survival of young trees is dependent upon the quick recycling of nutrients by the saprophytic fungi.

Every time catastrophes occur—hurricanes, tornadoes, volcanoes, floods, even earthquakes—the resulting dead wood becomes a stream of inexpensive substrate materials. In a sense, the cost of mushroom production is underwritten by natural disasters. Unfortunately, to date, few individuals and communities take advantage of catastrophia as fortuitous events for mushroom culture. However, once the economic value of recycling with gourmet and medicinal mushrooms is clearly understood, and with the increasing popularity of backyard cultivation, catastrophia can be viewed as a positive event, at least in terms of providing new economic opportunities for those who are mycologically astute.

## Mushrooms and Toxic Wastes

In heavily industrialized areas, soils are often contaminated with a wide variety of pollutants, particularly petroleum-based compounds, polychlorinated biphenols (PCB's), heavy metals, pesticide-related compounds, and even radioactive wastes. Mushrooms grown in polluted environments can absorb toxins directly into their tissues. As a result,

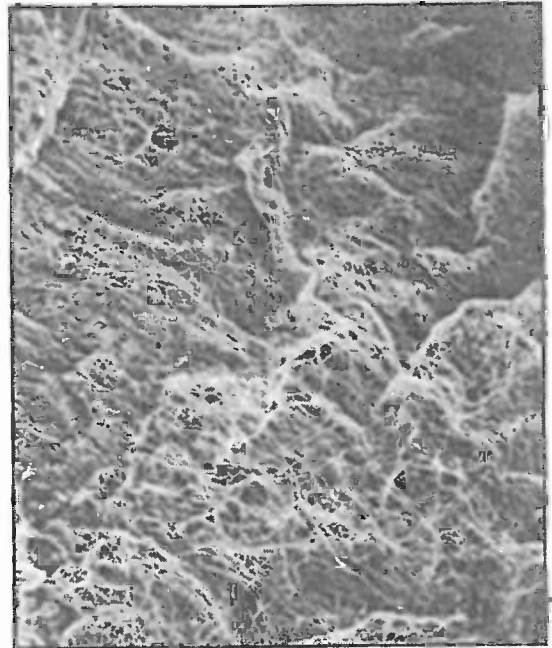

Figure 13. Scanning electron micrograph of the mycelial network.

mushrooms grown in these environments should not be eaten. Recently, a visitor to Ternobyl, a city about 60 miles from Chernobyl, the site of the world's worst nuclear power plant accident, returned to the United States with a jar of pickled mushrooms. The mushrooms were radioactive enough to set off Geiger counter alarms as the baggage was being processed. The mushrooms were promptly confiscated by Customs officials. Unfortunately, most toxins are not so readily detected.

A number of fungi can, however, be used to detoxify contaminated environments, a process called "bioremediation". The white rot fungi (particularly *Phanerochaete chrysosporium*) and brown rot fungi (notably *Gloeophyllum* species) are the most widely used. Most of these wood-rotters produce lig-

nin peroxidases and cellulases which have unusually powerful degradative properties. These extracellular enzymes have evolved to break down plant fiber, primarily lignin-cellulose, the structural component in woody plants, into simpler forms. By happenstance, these same enzymes also reduce recalcitrant hydrocarbons and other man-made toxins. Given the number of industrial pollutants that are hydrocarbon-based, fungi are excellent candidates for toxic waste clean-up and are viewed by scientists and government agencies with increasing interest. Current and prospective future uses include the detoxification of PCB (polychlorobiphenols), PCP (pentachlorophenol), oil, pesticide/herbicide residues, and even are being explored for ameliorating the impact of radioactive wastes.

Bioremediation of toxic waste sites is especially attractive because the environment is treated *in situ*. The contaminated soils do not have to be hauled away, eliminating the extraordinary expense of handling, transportation, and storage. Since these fungi have the ability to reduce complex hydrocarbons into elemental compounds, these compounds pose no threat to the environment. Indeed, these former pollutants could even be considered as "fertilizer", helping rather than harming the nutritional base of soils.

Dozens of bioremediation companies have formed to solve the problem of toxic waste. Most of these companies look to the imperfect fungi. The higher fungi should not be disqualified for bioremediation just because they produce fruitbody. Indeed, this group may hold answers to many of the toxic waste problems. The most vigorous rotters described in this book are the *Ganoderma* and

*Pleurotus* mushrooms. However, mushrooms grown from toxic wastes are best not eaten as residual toxins may be concentrated within the mushrooms.

## Mushroom Mycelium and Mycofiltration

The mycelium is fabric of interconnected, interwoven strands of cells. A colony can be the size of a half-dollar or many acres. A cubic inch of soil can host up to a mile of mycelium. This organism can be physically separated, and yet behave as one.

The exquisite lattice-like structure of the mushroom mycelium, often referred to as the *mycelial network*, is perfectly designed as a filtration membrane. Each colony extends long, complex chains of cells that fork repeatedly in matrix-like fashion, spreading to geographically defined borders. The mushroom mycelium, being a voracious forager for carbon and nitrogen, secretes extracellular enzymes that unlock organic complexes. The newly freed nutrients are then selectively absorbed directly through the cell walls into the mycelial network.

In the rainy season, water carries nutritional particles through this filtration membrane, including bacteria, which often become a food source for the mushroom mycelium. The resulting downstream effluent is cleansed of not only carbon/nitrogen-rich compounds but also bacteria, in some cases nematodes, and legions of other micro-organisms. Only recently has the classic saprophyte, the voracious Oyster mushroom, been found to be parasitic against nematodes. (See Thorn & Barron, 1984). The extracellular enzymes act like an anesthetic and stun the nematodes, thus allowing the invasion of

the mycelium directly into their immobilized bodies.

The use of mycelium as a mycofilter is currently being studied by this author in the removal of biological contaminants from surface water passing directly into sensitive watersheds. By placing sawdust implanted with mushroom mycelium in drainage ba-

sins downstream from farms raising livestock, the mycelium acts as a sieve which traps fecal bacteria and ameliorates the impact of a farm's nitrogen-rich outflow into aquatic ecosystems. This concept is incorporated into an integrated farm model and explored in greater detail in Chapter 5: Permaculture with a Mycological Twist.



## Selecting a Candidate for Cultivation

**M**any mushroom hunters would love to have their favorite edible mushroom growing in their backyard. Who would not want a patch of Matsutake, Shaggy Manes, giant Puffballs or the stately Prince gracing their property? As the different seasons roll along, gourmet mushrooms would arise in concert. Practically speaking, however, our knowledge of mushroom cultivation is currently limited to 100 species of the 10,000 thought to exist throughout the world. Through this book and the works of others, the number of cultivatable species will enlarge, especially if amateurs are encouraged to boldly experiment. Techniques for cultivating one species may be applied for cultivating another, often by substituting an ingredient, changing a formula, or altering the fruiting environment. Ironically, with species never before grown, the strategy of “benign neglect” more often leads to success than active interference with the natural progression of events. I have been particularly adept at this non-strategy. Many of my early mushroom projects only produced when I left them alone.

A list of candidates which can be grown using current methods follows. At present we do not know how to grow those species marked by an asterisk (\*). However, I believe techniques for their cultivation will soon be perfected, given a little experimentation. This list is by no means exclusive, and will be much amended in the future. Many of these mushrooms are described as good edibles in the field guides, as listed in the resource section of this book. (See Appendix IV. ).

## Woodland Mushrooms

### The Wood Ears

- Auricularia auricula*
- Auricularia polytricha*

### The Prince

- Agaricus augustus*

### The Almond Agaricus

- Agaricus subrufescens*

### The Sylvan Agaricus

- Agaricus sylvicola*
- Agaricus liliceps* \*

### Black Poplar Agrocybe

- Agrocybe aegerita*

### The Clustered Woodlovers

- Hypholoma capnoides*
- Hypholoma sublateritium*
- Psilocybe cyanescens and allies*

### Oyster-like Mushrooms

- Hypsizygus ulmarius*
- Hypsizygus tessulatus* (= *H. marmoreus*)
- Pleurotus citrinopileatus* (= *P. cornucopiae* var. *citrinopileatus*).
- Pleurotus cornucopiae*

- Pleurotus cystidiosus* (= *P. abalonus*, *P. smithii* (?))
- Pleurotus djamor* (= *P. flabellatus*, *P. salmoneo-stramineus*)
- Pleurotus dryinus* \*
- Pleurotus eryngii*
- Pleurotus euosmus*
- Pleurotus ostreatus*
- Pleurotus pulmonarius*  
(= "sajor-caju")
- Tricholoma giganteum*

### The Deer Mushroom

- Pluteus cervinus*

### Shiitake Mushroom

- Lentinula edodes*
- Lentinula* spp.

### Garden Giant or King Stropharia

- Stropharia rugoso-annulata*

## Grassland Mushrooms

### Meadow Mushrooms

- Agaricus campestris*
- Agaricus arvensis*
- Lepiota procera*

### Horse Mushroom

- Agaricus arvensis*

### The Giant Puffball

- Calvatia gigantea & allies* \*

### Smooth Lepiota

- Lepiota naucina* \*

### The Parasol Mushroom

- Lepiota procera*

### Fairy Ring Mushroom

- Marasmius oreades*

## Dung Inhabiting Mushrooms

### The Button Mushrooms

*Agaricus brunnescens*

*Agaricus bitorquis* (= *rodmanii*)

### The Magic Mushrooms

*Psilocybe cubensis*

*Panaeolus cyanescens* (= *Copelandia cyanescens*)

*Panaeolus subbalteatus*

*Panaeolus tropicalis* (*Copelandia tropicalis*)

## Compost/ Litter/ Disturbed Habitat Mushrooms

### Shaggy Manes

*Coprinus comatus*

### Scaly Lepiota

*Lepiota rachodes* \*

### The Termite Mushrooms

*Termitomyces spp.* \*

### The Blewit

*Lepista nuda*

---

---

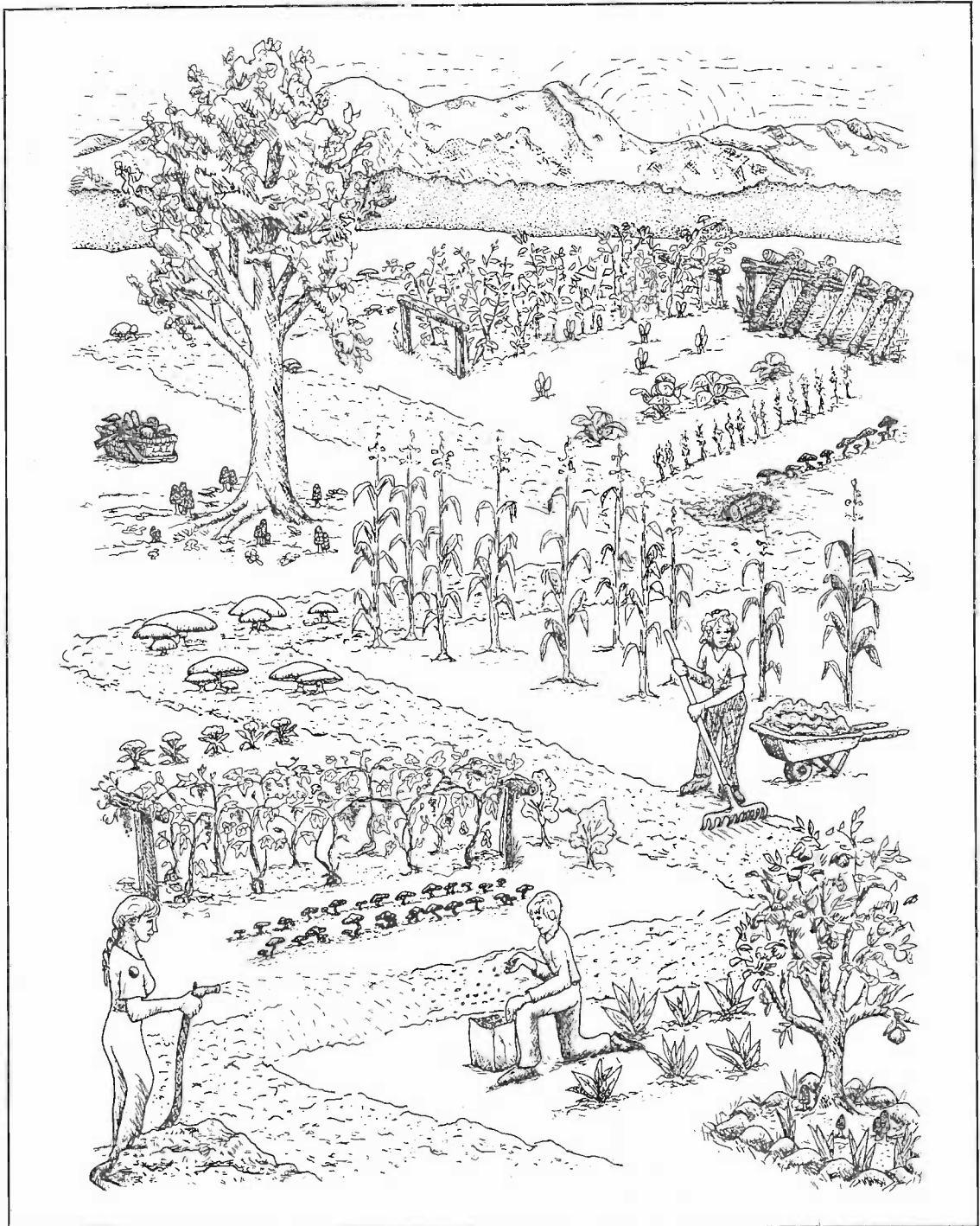

Figure 14. Gardening with gourmet and medicinal mushrooms.

# Natural Culture: Creating Mycological Landscapes

**N**atural culture is the cultivation of mushrooms outdoors. After mycological landscapes are constructed and inoculated, the forces of Nature take over. I also call this “laissez-faire” cultivation—in other words the mushroom patch is left alone, subject to the whims of Nature; except for some timely watering. The mushroom habitat is specifically designed, paying particular attention to site location and the use of native woods and/or garden by-products. Once prepared, the cultivator launches the selected mushroom species into a constructed habitat by spawning. In general, native mushroom species do better than exotic ones. However, even those obstacles to growing exotic species are easily overcome with some forethought to design, and the helpful suggestions of an experienced cultivator.

Every day, gardeners, landscapers, rhododendron growers, arborists, and nurseries utilize the very components needed for growing mushrooms. Every pile of debris, whether it is tree trimmings, sawdust or wood chips, or a mixture of these materials will support mushrooms. Unless selectively inoculated, debris piles become habitats of miscellaneous "weed" mushrooms, making the likelihood of growing a desirable mushroom remote.

When inoculating an outdoor environment with mushroom spawn, the cultivator relinquishes much control to natural forces. There are obvious advantages and disadvantages to natural culture. First, the mushroom patch is controlled by volatile weather patterns. This also means that outdoor beds have the advantage of needing minimum maintenance. The ratio of hours spent per lb. of mushrooms grown becomes quite efficient. The key to success is creating an environment wherein the planted mycelium naturally and vigorously expands. A major advantage of growing outdoors compared to growing indoors is that competitors are not concentrated in a tight space. When cultivating mushrooms outdoors you have *entropy as an ally*.

The rate of growth, time to fruiting, and quality of the crop depends upon the spawn, substrate materials, and weather conditions. Generally, when mushrooms are fruiting in the wild, the inoculated patches also produce. Mushrooms that fruit primarily in the summer, such as the King Stropharia (*Stropharia rugoso-annulata*) require frequent watering. Shaggy Manes (*Coprinus comatus*) prefer the cool, fall rains, thus requiring little attention. In comparison to indoor cultivation, the outdoor crops are not as frequent. However, outdoor crops can be just as intense, sometimes more so, especially if one is paying modest attention to the needs of the mushroom mycelium at critical junctures throughout its life cycle.

While the cultivator is competing with molds indoors, wild mushrooms are the major competitors outdoors. You may plant one species in an environment where another species is already firmly established. This is especially likely if you use old sawdust, chips or base materials. Starting with fresh materials is the simplest way to avoid this problem. Piles of aged wood chips commonly support four or five species of mushrooms within just a few square feet. *Unless, the cultivator uses a high rate of inoculation (25% spawn/substrate) and uniformly clean wood chips, the concurrence of diverse mushroom species should be expected.* If, for instance, the backyard cultivator gets mixed wood chips in the early spring from a county road maintenance crew, and uses a dilute 5-10% inoculation rate of sawdust spawn into the chips, the mushroom patch is likely to have wild species emerging along with the desired mushrooms.

In the Pacific Northwest of North America, I find a 5-10% inoculation rate usually results in some mushrooms showing late in the first year, the most substantial crops occurring in the second and third years, and a dramatic drop-off in the fourth year. As the patch ages, it is normal to see more diverse mushroom varieties co-occurring with the planted mushroom species.

I am constantly fascinated by the way Nature re-establishes a polyculture environment at the earliest opportunity. Some mycologists believe a pre-determined, sequence of mycorrhizal and saprophytic species prevails, for instance, around a Douglas fir tree, as it matures. In complex natural habitats, the interlacing of mycelial networks is common. Underneath a single tree, twenty or more species may thrive. I look forward to the 21st century, when mycotopian foresters will design whole species mosaics upon whose foundation vast ecosystems can flourish. This book will describe simpler, precursor models for

---

mixing and sequencing species. I hope these concepts will be further developed by imaginative and skilled cultivators.

In one of my outdoor wood chip beds, I created a “polyculture” mushroom patch about 50 x 100 feet in size. In the spring I acquired mixed wood chips from the county utility company—mostly alder and Douglas fir—and inoculated three species into it. One year after inoculation, in late April through May, Morels showed. From June to early September, King Stropharia erupted with force, providing our family with several hundred pounds. In the late September through much of November, an assortment of Clustered Wood lovers (*Hypholoma*-like) species popped up. With non-coincident fruiting cycles, this Zen-like polyculture approach is limited only by your imagination.

Species succession can be accomplished indoors. Here is one example. After Shiitake stops producing on logs or sawdust, the substrate can be broken apart, re-moistened, re-sterilized, and re-inoculated with another gourmet mushroom, in this case, I recommend Oyster mushrooms. Once the Oyster mushroom life cycle is completed, the substrate can be again sterilized, and inoculated with the next species. Shiitake, Oyster, King Stropharia and finally Shaggy Manes can all be grown on the same substrate, increasingly reducing the substrate mass, without the addition of new materials. The majority of the substrate mass that does not evolve into gases is regenerated into mushrooms. The conversion of substrate mass-to-mushroom mass is mind boggling. These concepts are further developed in Chapter 22.

The following list of decomposers are wild mushrooms most frequently occurring in wood chips in the northern temperate regions of North America. In general, these natural competitors are easy to distinguish from the gourmet mush-

room species described in this book. Those that are mildly poisonous are labelled with \*; those which are deadly have two \*\*. This list is by no means comprehensive. Many other species, especially the poisonous mycorrhizal *Amanita*, *Hebeloma*, *Inocybe* & *Cortinarius* species are not listed here. Mushrooms from these genera can inhabit the same plot of ground where a cultivator may lay down wood chips, even if the host tree is far removed.

## Some Wild Mushrooms Naturally Found in Beds of Wood Chips

Ground lovers

*Agrocybe* spp. and *Pholiota* spp.

The Sweaters

*Clitocybe* spp. \*

The Inky Caps

*Coprinus atramentarius*\*

*C. comatus*

*C. disseminatus*

*C. lagopus*

*C. micaceus* & allies

The Vomited Scrambled Egg Fungus

*Fuligo cristata*

The Deadly Galerinas

*Galerina autumnalis* & allies \*\*

Red-Staining Lepiotas

*Lepiota* spp. \*\*

The Clustered Woodlover

*Hypholoma capnoides*

The Green-Gilled Clustered Woodlover

*Hypholoma fasciculare*\*

The Chestnut Mushroom

*Hypholoma sublateritium*

The Deadly Ringed Cone Heads

*Pholiotina filaris* and allies\*\*

*Pholiota terrestris* and allies

The Deer Mushroom

*Pluteus cervinus*

Black Spored Silky Stems

*Psathyrella spp.*

The Caramel Capped Psilocybes

*Psilocybe cyanescens & allies*

The mushrooms in the *Galerina autumnalis* and *Pholiotina filaris* groups are deadly poisonous. Some species in the genus *Psilocybe* contain psilocybin and psilocin, compounds which often cause uncontrolled laughter, hallucinations, and sometimes spiritual experiences. Outdoor cultivators must hone their skills at mushroom identification to avert the accidental ingestion of undesired mushrooms. Recommended mushroom field guides and mushroom identification courses are listed in the Resource section of this book.

## Methods of Mushroom Cultivation

Mushrooms can be cultivated through a variety of methods. Some techniques are exquisitely simple, and demand little or no technical expertise. Others—involving sterile tissue culture—are much more technically demanding. The simpler methods take little time, but also require more patience and forgiveness on the part of the cultivator, lest the mushrooms do not appear according to your time-table. As one progresses to the more technically demanding methods, the probability of success is substantially increased, with mushrooms appearing exactly on the day scheduled.

The simpler methods for mushroom cultivation, demanding little or no technical expertise, are outlined in this chapter. They are: *spore mass inoculation, transplantation and inoculation with pure cultured spawn.*

## Spore Mass Inoculation

By far the simplest way to grow mushrooms is to broadcast spores onto prepared substrates outdoors. First, spores of the desired species must be collected. Spore collection techniques vary, according to the shape, size, and type of the mushroom candidate.

For gilled mushrooms, the caps can be severed from the stems, and laid, gills down, on top of clean typing paper, glass, or similar surface. (See Figure 15.) A glass jar or bowl is placed over the mushroom to lessen the loss of water. After 12 hours, most mushrooms will have released thousands of spores, falling according to the radiating symmetry of the gills, in an attractive outline called a *Spore Print*. This method is ideal for mushroom hunters “on the go” who might not be able to make use of the spores immediately. After the spores have fallen, the spore print can be sealed, stored, and saved for future use. It can even be mailed without harm.

By collecting spores of many mushrooms, one creates a **Species Library**. A mushroom hunter may find a species only once in a lifetime. Under these circumstances, the existence of a spore print may be the only resource a cultivator has for future propagation. I prefer taking spore prints on a pane of glass, using duct tape as binding along one edge. The glass panes are folded together, and masking tape is used to seal the three remaining edges. This spore book is then registered with notes written affixed to its face as to the name of mushroom, the date of collection, the county and locality of the find. Spores collected in this fashion remain viable for years, although viability decreases over time. They should be stored in a dark, cool location, low in humidity and free from temperature fluctuation. Techniques for creating cultures from spores are explained further on.



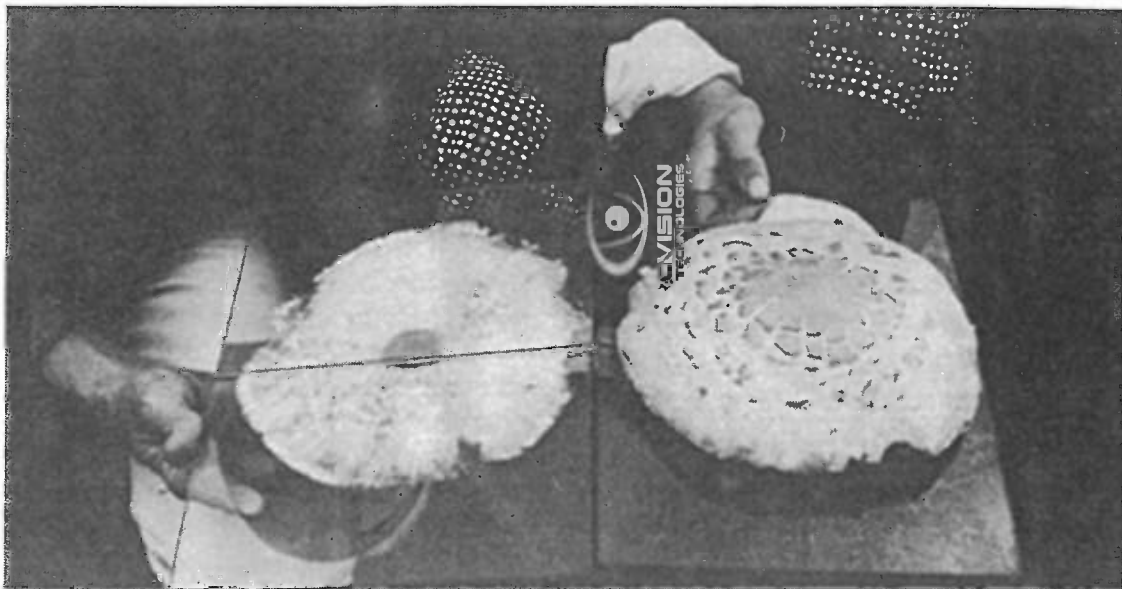

Figure 15. Collecting the spores of the delicious *Lepiota rachodes*, a Parasol Mushroom, on two panes of glass which are then folded together, creating a Spore Booklet.

For those wishing to begin a mushroom patch using fresh specimens, a more efficient method of spore collection is recommended. This method calls for the immersion of the mushroom in water to create a *spore mass slurry*. Choose fairly mature mushrooms and submerge them in a 5-gallon bucket of water. A gram or two of table salt inhibits bacteria from growing while not substantially affecting the viability of the spores. By adding 50 ml. of molasses, spores are stimulated into frenzied germination. After four hours of soaking, remove the mushroom(s) from the bucket. Most mushrooms will have released tens of thousands of spores. Allow the broth to sit for 24-48 hours at a temperature above 50° F. (10° C.) but under 80° F. (27° C.) In most cases, spores begin to germinate in minutes to hours, aggressively in search of new mates and nutrients. This slurry can be expanded by a factor of ten in 48 hours. (I

have often dreamed, being the mad scientist, of using spore mass slurries of Morels and other species to aerially “bomb” large expanses of forest lands. This idea, as crazy as it may initially sound, warrants serious investigation.)

During this stage of frenzied spore germination, the mushroom patch habitat should be designed and constructed. Each species has unique requirements for substrate components for fruiting. However, mycelia of most species will run through a variety of lignin-cellulosic wastes. Only at the stage when fruitbody production is sought does the precise formulation of the substrate become crucial.

Oyster (*Pleurotus ostreatus*, *P. eryngii* and allies), King Stropharia (*Stropharia rugoso-annulata*), and Shaggy Mane (*Coprinus comatus*) mushrooms thrive in a broad range of substrate formulations. Other mushrooms such as Morels (*Morchella angusticeps* & *esculenta*) are more restrictive in their requirements. Since

there are several tracks that one can pursue to create suitable habitats, refer to Chapter 21 for more information.

### **Transplantation: Mining Mycelium from Wild Patches**

Transplantation is the moving of mycelium from natural patches to new habitats. Most wild mushroom patches have a vast mycelial network emanating beneath each mushroom. Not only can one harvest the mushroom, but portions of the mycelial network can be gathered and transferred to a new location. This method ensures the quick establishment of a new colony without having to germinate spores or buying commercial spawn.

When transplanting mycelium, I use a paper sack or a cardboard box. Once mycelium is disturbed, it quickly dries out unless measures are taken to prevent dehydration. After it is removed from its original habitat, the mycelium will remain viable for days or weeks, as long as it is kept moist in a cool, dark place.

Gathering the wild mycelium of mycorrhizal mushrooms could endanger the parent colony. Be sure you cover the divot with wood debris and press tightly back into place. In my opinion, mycorrhizal species should not be transplanted unless the parent colony is imminently threatened with loss of habitat—such as logging, construction, etc. Digging up mycelium from the root zone of a healthy forest can jeopardize the symbiotic relationship between the mushroom and its host tree. Exposed mycelium and roots become vulnerable to disease, insect invasion, and dehydration. Furthermore, transplantation of mycorrhizal species has a lower success rate than the transplantation of saprophytic mushrooms.

If done properly, transplanting the mycelium of saprophytic mushrooms is not threatening to naturally occurring mushroom colonies. Some of the best sites for finding mycelium for transplantation are sawdust piles. Mycelial networks running through sawdust piles tend to be vast and relatively clean of competing fungi. Fans of mycelium are more often found along the periphery of sawdust piles than within their depths. When sawdust piles are a foot deep or more, the microclimate is better suited for molds and thermophilic fungi. These mold fungi benefit from the high carbon dioxide and heat generated from natural composting. At depths of 2-6 inches, mushroom mycelia runs vigorously. It is from these areas that mushroom mycelium should be collected for transplantation to new locations. One, in effect, engages in a form of *mycelial mining* by encouraging the growth and the harvesting of mycelium from such environments. Ideal locations for finding such colonies are sawmills, nurseries, composting sites, recycling centers, rose and rhododendron gardens, and soil mixing companies.

### **Inoculating Outdoor Substrates with Pure Cultured Spawn**

In the early history of mushroom cultivation, mycelium was collected from the wild and transplanted into new substrates with varying results. Soon compost spawn (for the Button Mushroom (*Agaricus brunnescens*)) evolved with greater success. In 1933, spawn technology was revolutionized by Sinden's discovery of grain as a spawn carrier medium. Likewise, Stoller (1962) significantly contributed to the technology of mushroom cultivation through a series of practical advances in using plastic

---

bags, collars and filters.\* *The Mushroom Cultivator* (Stamets and Chilton, 1983) decentralized tissue culture for spawn generation, empowering far more cultivators than ever before. Legions of creative individuals embarked on the path of exotic mushroom production. Today, thousands of cultivators are contributing to an ever-expanding body of knowledge, and setting the stage for the cultivation of many gourmet and medicinal fungi of the future.

The advantage of using commercial spawn is in acquiring mycelium of higher purity than can be harvested from nature. Commercial spawn can be bought in two forms: grain or wood (sawdust or plugs). For the inoculation of outdoor, unpasteurized substrates, wood-based spawn is far better than grain spawn. When grain spawn is introduced to an outdoor bed, insects, birds, and slugs quickly seek out the nutritious kernels for food. Sawdust spawn has the added advantage of having more particles or *inoculation points* per lb. than does grain. With more points of inoculation, colonization is accelerated. The distances between mycelial fragments is lessened, making the time to contact less than that which happen with grain spawn. Thus the window of vulnerability is closed to many of the diseases that eagerly await intrusion.

Before spawn is used, the receiving habitat is moistened to near saturation. The spawn is then mixed thoroughly through the new habitat with your fingers or a rake. Once inoculated, the new bed is again watered. The bed can be covered with cardboard, shade cloth, scrap wood, or similar material to protect the mycelium from sun exposure and dehydration. After inoculation, the bed is ignored, save for an occasional inspection and watering once a week,

\* In 1977, B. Stoller & J. Azzolini were awarded U.S. patent # 4027427 for this innovation.

and then only when deemed necessary.

Certain limitations prevail in the expansion of mycelium and its ability for colonizing new substrates. The intensity or rate of inoculation is extremely important. If the spawn is too dispersed into the substrate, the points of inoculation will be not be close enough to result in the rapid re-establishment of one, large, contiguous mycelial mat. My own experiences show that success is seen with an inoculation rate of 5-50%, with an ideal of 20%. In other words, if you gather a 5-gallon bucket of naturally occurring mycelium, 20 gallons of prepared substrate can be inoculated. Although this inoculation rate may seem high, rapid colonization is assured. A less intensive inoculation rate of 10% is often used by more skilled cultivators, whose methods have been refined through experience. Inoculation rates of 5% or less often result in "island" colonies of the implanted species interspersed amongst naturally occurring, wild mushrooms.

At a 20% inoculation rate, colonization can be complete in as short as one week and as long as eight. After a new mycelial mat has been fully established, the cultivator has the option of further expanding the colony by a factor of 5, or triggering the patch into fruiting. This usually means providing shade and frequent watering. Should prevailing weather conditions not be conducive to fruiting and yet are above freezing, then the patch can be further expanded. Should the cultivator not expect that further expansion would result in full colonization by the onset of winter, then no new raw material should be added, and mushrooms should be encouraged to form. At the time when mushrooms are forming, colonization of new organic debris declines or abates entirely. The energy of the mycelium is now channeled to fruitbody formation and development.



Figure 16: Establishing an outdoor mushroom bed. Layer of moist mulch placed along edge of garden bed.

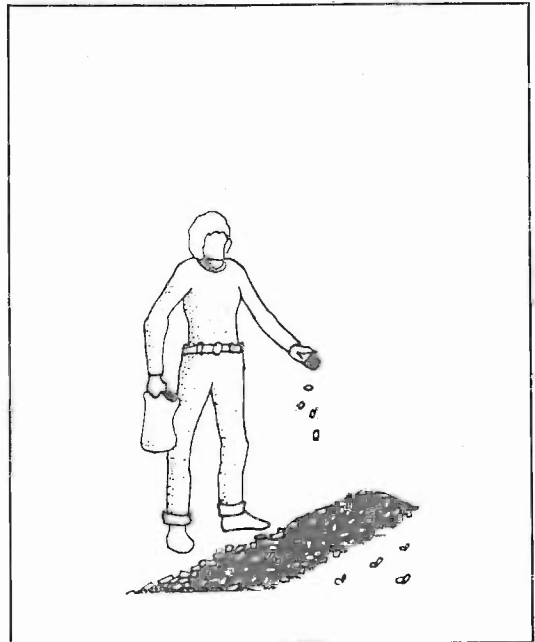

Sprinkling spawn on top of mulch layer.

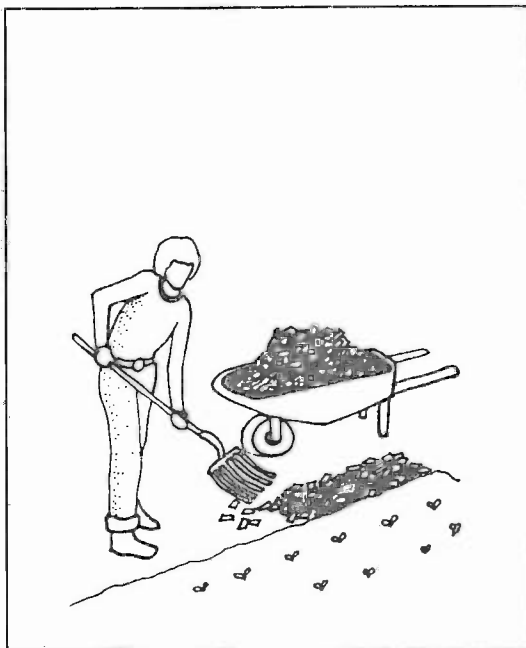

Adding more moist mulch over the spawn layer.

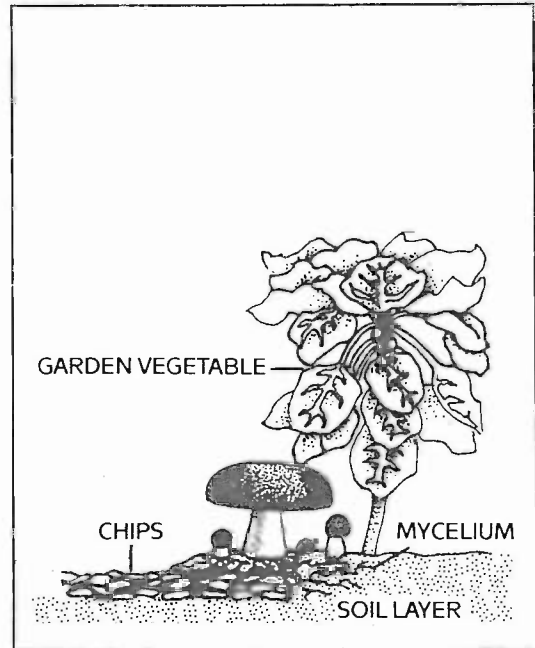

Cross section of garden bed showing mycelium and mushroom growth.



Figure 17. Healthy *Stropharia rugoso-annulata* mycelium tenaciously gripping alder chips and sawdust. Note rhizomorphs.

The mycelium of saprophytic mushrooms must move to remain healthy. When the mycelium reaches the borders of a geographically or nutritionally defined habitat, a resting period ensues. If not soon triggered into fruiting, over-incubation is likely, with the danger of "die-back." Only very cold temperatures will keep the patch viable for a prolonged period. Typically, die-back is seen as the drastic decline in vigor of the mycelium. Once the window of opportunity has passed for fruiting, the mushroom patch might be salvaged by the re-introduction of more undecomposed organic matter, or by violent disturbance. The mycelium soon becomes a site for contamination with secondary decomposers (weed fungi) and predators (insects) coming into play. It is far better to *keep the mycelium running* until fruitings can be triggered. Mushroom patches

are, by definition, temporary communities.

King *Stropharia* lasts three to four years on a hardwood chip base. After the second year more material should be added. However, if the health of the patch has declined and new material is mixed in, then the mushroom patch may not recover to its original state of vigor. Mycelium that is healthy tends to be tenacious, holding the substrate particles together. This is especially true with *Stropharia* and Oyster mushrooms. (*Hericium erinaceus* and *Morchella* spp. are exceptions.) Over-incubation results in a weakened mycelial network which is incapable of holding various substrate particles together. As mycelial integrity declines, other decomposers are activated. Often, when mixing in new material at this stage, weed fungi proliferate, to the decided disadvantage of the selected gourmet species. To the eye, the colony no longer looks like a continuous sheet



Figure 18. From the same patch, three years later, the wood chips have decomposed into a rich soil-loam.

of mycelium, but becomes spotty in its growth pattern. Soon islands of mycelium become smaller and smaller as they retreat, eventually disappearing altogether. The only recourse is to begin anew, scraping away the now-darkened wood/soil, and replacing it with a new layer of wood chips and/or other organic debris.

## When to Inoculate an Outdoor Mushroom Patch

Outdoor beds can be inoculated in early spring to early fall. The key to creating a mushroom bed is that the mycelium must have sufficient time to establish a substantial mycelial mat before the onset of inclement weather conditions. Spring time is generally the best time to inoculate, especially for creating large mushroom patches. As fall approaches, mushroom beds more modest in size should be established, with a correspondingly higher rate of inoculation. For most saprophytic species, at least four weeks are required to form the mycelial network with the critical mass necessary to survive the winter.

Most woodland species survive wintering temperatures. Woodland mushrooms have evolved protective mechanisms within their cellular network that allow them to tolerate temperature extremes. Surface frosts usually do not harm the terrestrially bound mushroom mycelium. As the mycelium decomposes organic matter, heat is released, which benefits subsurface mycelium. Mycelial colonization essentially stops when outdoor temperatures fall below freezing.

## Site Location of a Mushroom Patch

A suitable site for a mushroom patch is easy to choose. The best clue is to simply take note

of where you have seen mushrooms growing during the rainy season. Or just observe where water traverses after a heavy rain. A gentle slope, bordered by shrubs and other shade-giving plants, is usually ideal. Since saprophytic mushrooms are non-competitive to neighboring plants, they pose no danger to them. In fact, plants near a mushroom bed often thrive—the result of the increased moisture retention and the release of nutrients into the root zone.

An ideal location for growing mushrooms is in a vegetable, flower, and/or rhododendron garden. Gardens are favored by plentiful watering, and the shade provided by potato, zucchini, and similar broad-leaf vegetable plants tend to keep humidity high near the ground. Many gardeners bring in sawdust and wood chips to make pathways between the rows of vegetables. By increasing the breadth of these pathways, or by creating small cul-de-sacs in the midst of the garden, a mushroom bed can be ideally located and maintained (see Figure 14).

Other suitable locations are exposed north sides of buildings, and against rock, brick, or cement walls. Walls are usually heat sinks, causing condensation which provides moisture to the mushroom site as temperatures fluctuate from day to night. Protected from winds, these locations have limited loss of water due to evaporation.

Mushrooms love moisture. By locating a mushroom bed where moisture naturally collects, colonization is rapid, more complete, and the need for additional water for fruiting is minimized. The message here: choose your locations with moisture foremost in mind. Choose shady locations over sunny ones. Choose north-facing slopes rather than south-facing. Choose companion plants with broad-leaves or canopies that shade the mid-day sun but allow rain to pass. The difference in results is the difference between a

---



Figure 19. Giant Oyster mushrooms fruiting from stump.

bountiful success and a dismal failure.

## Stumps as Platforms for Growing Mushrooms

Stumps are especially suitable for growing gourmet mushrooms. There are few better, or more massive platforms, than the stump. Millions of stumps are all that remain of many forests of the world. In most cases, stumps are seen as having little or no economic potential. These lone tombstones of biodegradable wood fiber offer a unique, new opportunity for the mycologically astute. With selective logging being increasingly practiced, cultivating gourmet and medicinal mushrooms on stumps will be the wave of the future.

The advantage of the stump is not only its sheer mass, but with roots intact, water is continuously being drawn via capillary action through the dead wood cells from the underlying soil base. Once mycelium has permeated through wood fiber, the stump's water carrying capacity is increased, thus further supporting mycelial growth. Candidates for stump culture must be carefully selected and matched with the appropriate species. A stump partially or fully shaded is obviously better than one in full sun-

light. Stumps in ravines are better candidates than those located in the center of a clear-cut. An uprooted stump is not as good a candidate as a well-rooted one. The presence of mosses, lichens, and/or ferns is a good indicator that the microclimate is conducive to mushroom growth. However, the presence of competitor fungi generally disqualifies a stump as a good candidate. These are some of the many factors that determine the suitability of stumpage.

Cultivating mushrooms on stumps requires forethought. Stumps should be inoculated before the first season of wild mushrooms. With each mushroom season, the air becomes laden with spores, seeking new habitats. The open face of a stump, essentially a wound, is highly susceptible to colonization by wild mushrooms. With the spore cast from wild competitors, the likelihood of introducing your species of choice is greatly reduced. If stumps are not inoculated within several months of being cut, the probability of success decreases. Therefore, old stumps are poor candidates. Even so, years may pass after inoculation before mushrooms form on a stump.

Large diameter stumps can harbor many communities of mushrooms. On old-growth or second-growth Douglas fir stumps common to the forests of Washington state, finding several species of mushrooms is not unusual. This natural example of "polyculture"—the simultaneous concurrence of more than one species in a single habitat—should encourage experimentally inclined cultivators. Mushroom landscapes of great complexity could be designed. However, the occurrence of poisonous mushrooms should be expected. Two notable, toxic mushrooms frequent stumps: *Hypholoma fasciculare* (= *Naematoloma fasciculare*) which causes gastro-intestinal upset but usually not death, and *Galerina autumnalis*, a mushroom that does kill. Because of the similarity in appearance between

*Flammulina velutipes* (Enoki) and *Galerina autumnalis*, I hesitate to recommend the cultivation of Enoki mushrooms on stumps unless the cultivator is adept at identification. (To learn how to identify mushrooms, please refer to the recommended mushroom field guides listed in Appendix IV.)

Several polypores are especially good candidates for stump cultivation, particularly *Grifola frondosa*—Maitake, and *Ganoderma lucidum*—Reishi and its close relatives. As the anti-cancer properties of these mushrooms become better understood, new strategies for the cultivation of medicinal mushrooms will be developed. I envision the establishment of Maitake & Reishi mushroom tree farms wherein stumps are purposely created and selectively inoculated for maximum mushroom growth, interspersed amongst shade trees. Once these models are perfected, other species can be incorporated in creating a multi-canopy medicinal forest.

On a well-travelled trail in the Snoqualmie Forest of Washington State, hikers have been stepping upon the largest and oldest Polypore: *Oxyporus nobilissimus*, a conk that grows up to several feet in diameter and which can weigh hundreds of pounds! This species grows only on old growth *Abies procera* (California red fir) or on their stumps. Less than a dozen specimens have ever been collected. Known only from the old growth forests of the Pacific Northwest, the Noble Polypore's ability to produce a conk that lives for more than 25 years distinguishes it from any other mushroom. This fact—that it produces a fruiting body that survives for decades—suggests that the Noble Polypore has unique anti-rotting properties from antibiotics or other compounds that could be useful medicinally. These examples from the fungal kingdom attract my attention in the search for candidates having potential for new medicines. With the loss of old-

growth forests, cultivator-mycologists can play an all-important role in saving the fungal genome from the old-growth forest, a potential treasure trove of new medicines.

Small-diameter stumps rot faster and produce crops of mushrooms sooner than bigger stumps. However, the smaller stump has a shorter mushroom-producing life span than the older stump. Often times with large diameter stumps, mushroom formation is triggered when competitors are encountered and/or coupled with wet weather conditions. The fastest I know of a stump producing from inoculation is 8 weeks. In this case, an oak stump was inoculated with plug spawn of Chicken-of-the-Woods, *Laetiporus (Polyporus) sulphureus*. Notably, the stump face was checkered—with multiple fissures running vertically through the innermost regions of the wood. These fissures trapped water from rainfall and promoted fast mycelial growth. As with the growing of any mushrooms, *the speed of colonization* is a determining factor in the eventual success or failure of any cultivation project.

For foresters and ecologists, actively inoculating and rotting stumps has several obvious advantages. Rather than allowing a stump to be randomly decomposed, species of economic or ecological significance can be introduced. For instance, a number of Honey mushrooms, belonging to the genus *Armillaria*, can operate as both saprophytes or parasites. Should clear-cuts become colonized with these deadly, root-rotting species, satellite colonies can be spread to adjacent, living trees. Now that burning is increasingly restricted because of air pollution concerns, disease vectors coming from stumpage could present a new, as yet unmeasured, threat to the forest ecosystem.

The advantages of growing on stumps can be summarized as:

- 1) Developing a new, environmentally





Figure 20. Drilling and inoculating a stump with plug spawn.

friendly wood products-based industry.

2) Recycling wood debris of little or no economic value.

3) Prevention of disease vectors from parasitic fungi.

4) Rapidly returning organic nutrients into the food chain, benefitting other citizens of the forest community and invigorating the ecosystem.

Few studies have been published on recycling stumps with mushrooms. One notable work from eastern Europe, published by Pagony (1973), describes the cultivation of Oyster mushrooms (*Pleurotus ostreatus*) on large diameter poplars with a 100% success rate. Inoculations occurred in the spring for fruitings which began in the ensuing fall, and continued for several years hence. An average of four pounds of Oyster mushrooms were harvested over four years (i. e. 1 lb. /year/stump).

Hilber (1982) also reported on the utility of using natural wood (logs & stumps) for growing Oyster mushrooms, and that per cubic meter of elm wood, the yield from one season averaged 17-22 kilograms. A study in France by Anselmi & Deandrea (1979) where poplar and willow stumps were inoculated with spawn of the Oyster mushroom showed that this mushroom favored wood from newly felled trees, in zones which received speckled sunlight. This study confirmed that *Pleurotus ostreatus* only attacked dead wood and never became parasitic. Their study supports my opinion (Stamets (1990)) that the purposeful inoculation of stumps can forestall the invasion by parasites like Honey Mushrooms of the *Armillaria mellea* complex. Mushrooms of this group first kill their host and then continue to live saprophytically. A stump with Honey Mushrooms can later destroy neighboring living trees. In Washington State, one colony of Honey Mushrooms is blamed for destroying hundreds of acres of conifers.

Inoculating stumps with strains cloned from native mushrooms is favored over the use of exotic fungi. Spring inoculations give the mycelium the longest possible growing season. Stumps can be inoculated by one of several simple procedures. Plug spawn can be inserted into the open face of each stump. If the stumps are checkered through with cracks, the plugs are best inserted directly into the fissures. Another method is known as the wedge or disc inoculation technique. Using a chain saw, a wedge is cut or a shallow disc is sliced from the open face of the stump. The newly cut faces are packed with sawdust spawn. The cut disc is then replaced. By hammering a few nails into the stump, you can assure firm contact between the cut faces.

The broad-leaf hardwoods are easier to

saprophytize with the gourmet and medicinal mushroom species described in this book than the softwood pines. And within the hardwood group, the rapidly growing species such as the alders and poplars decompose more rapidly—and hence give an earlier crop—than the denser hardwoods such as the oaks, etc. However, the denser and more massive stumps sustain colonies of mushrooms for many more years than the quick-to-rot, smaller diameter tree species. In a Colonial graveyard in New York state, a four foot diameter oak has consistently produced clusters of Maitake mushrooms, sometimes weighing up to 100 lbs. apiece, for more than 20 years!

Stump cultivation has tremendous potential. This unexploited resource—stumpage—can become production sites of gourmet and medicinal mushrooms. Although more studies are needed to ascertain the proper matching

of species to the wood types, I encourage you to experiment. Only a few minutes are required to inoculate a stump or dead tree. The potential rewards could span a lifetime.

## Log Culture

Log culture was developed in Japan and China more than a millennium ago. Even today, thousands of small-scale Shiitake growers in Asia use log culture to provide the majority of mushrooms sold to markets. In their backyards and along hillsides, inoculated logs are stacked like cordwood or in fence-like rows. These growers supply local markets, generating a secondary income for their families. Attempts to reproduce this model of Shiitake cultivation in North America and Europe has met with modest success.

The advantage of log culture is that it is a simple and natural method. The disadvantage

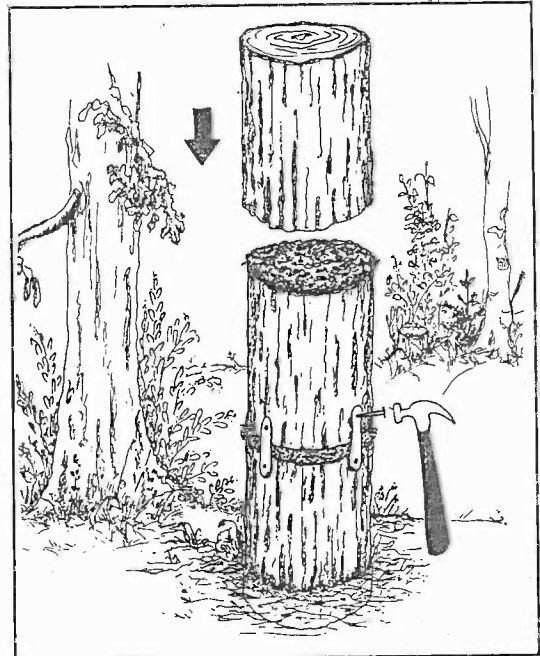
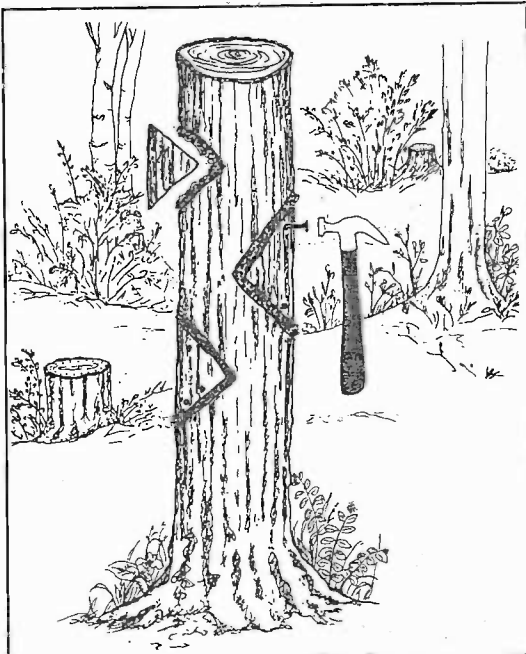

Figures 21 and 22. Inoculating a stump with the wedge and the spawn disc technique.

is that the process is labor-intensive, and slow in comparison to growing mushrooms on sterilized sawdust. Besides Shiitake, many other mushrooms can be grown on logs, including Nameko (*Pholiota nameko*), all the Oyster-like mushrooms (*Pleurotus* and *Hypsizygos spp.*), Lion's Mane (*Hericium erinaceus*), Wood Ears (*Auricularia* species), Clustered Wood Lovers (*Hypholoma capnoides* and *H. sublateritium*) and Reishi (*Ganoderma lucidum*). Since log culture is not technically demanding, anyone can do it. In contrast, growing on sterilized substrates requires specialized skills and involves training in laboratory techniques.

Logs are usually cut in the winter or early spring before leafing, when the sapwood is rich in sugars, to a meter in length and 4-10 inches in diameter. Cultivators generally favor logs which have a higher ratio of sapwood to heartwood. (These logs come from fast-growing tree

species like alder, poplar or cottonwood.) Once inoculated with sawdust or plug spawn, the logs (or "billets") are stacked in ricks and, after 6-12 months, are initiated by heavy watering or soaking. After soaking, the logs are lined up in fence-like rows. Japanese growers have long favored the "soak and strike" method for initiating mushroom formation. (See Figures 24 and 25.) Before the advent of plug and sawdust spawn, newly cut logs would be placed near to logs already producing Shiitake so that the spores would be broadcasted onto them. This method, although not scientific, succeeded for centuries, and still is a pretty good method. After a year, logs showing no growth, or the growth of competitor fungi, are removed from the production rows.

A wide variety of broad-leaf hardwoods are suitable for log culture. Oaks, and similar dense hardwoods with thick outer barks, are preferred

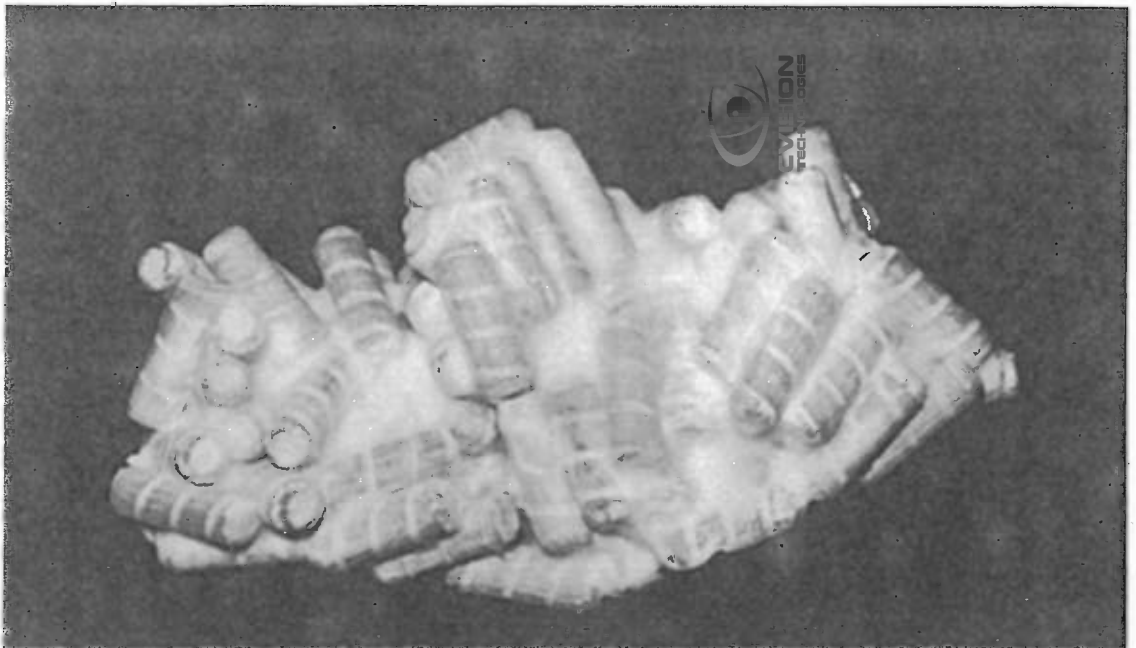

Figure 23. Plug spawn of Shiitake. Spirally grooved wooden dowels help the mycelium survive from the concussion of inoculation.



Figure 24. The “soak and strike” method for initiating Shiitake.

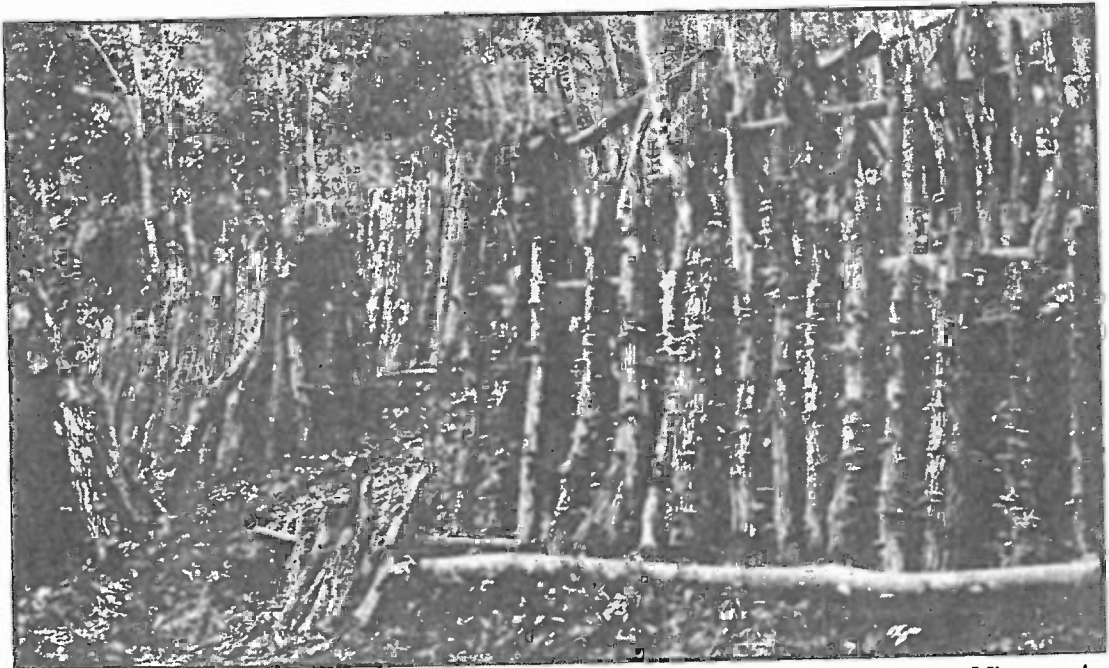

Figure 25. Natural Culture of Shiitake in the mountains of Japan. (Photographs, both from Mimura, circa 1915, Japan.)

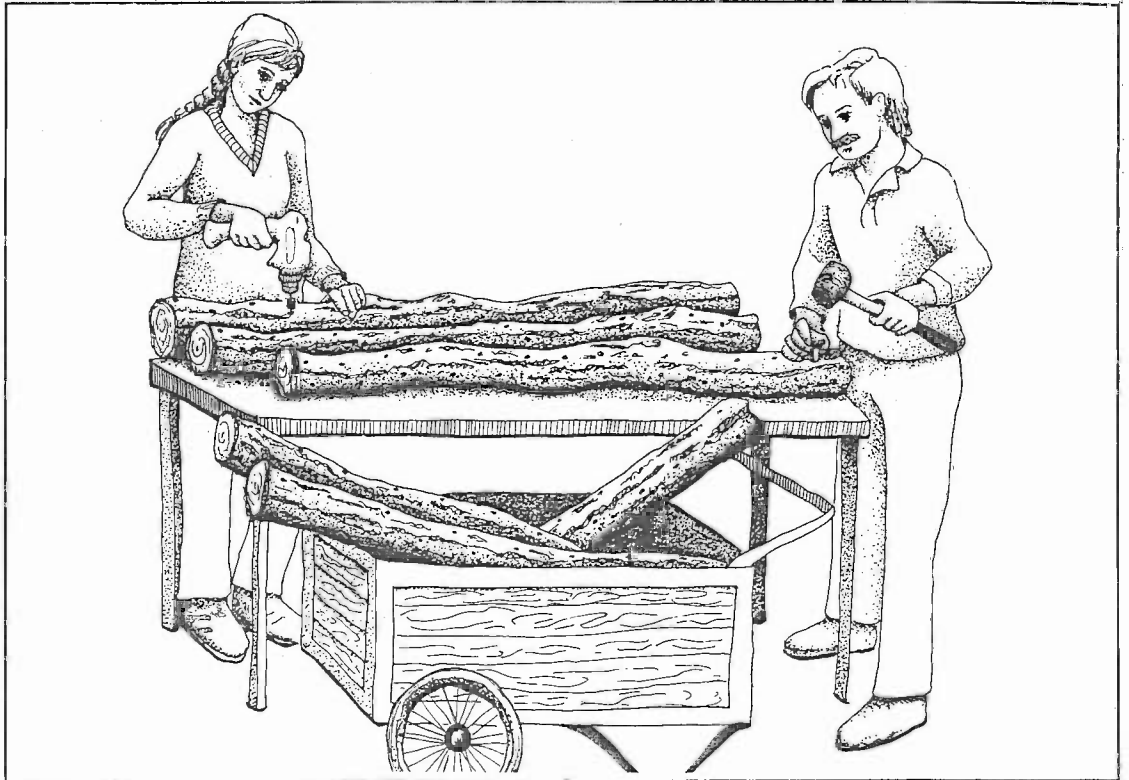

Figure 26. Drilling and inoculating plugs into logs.

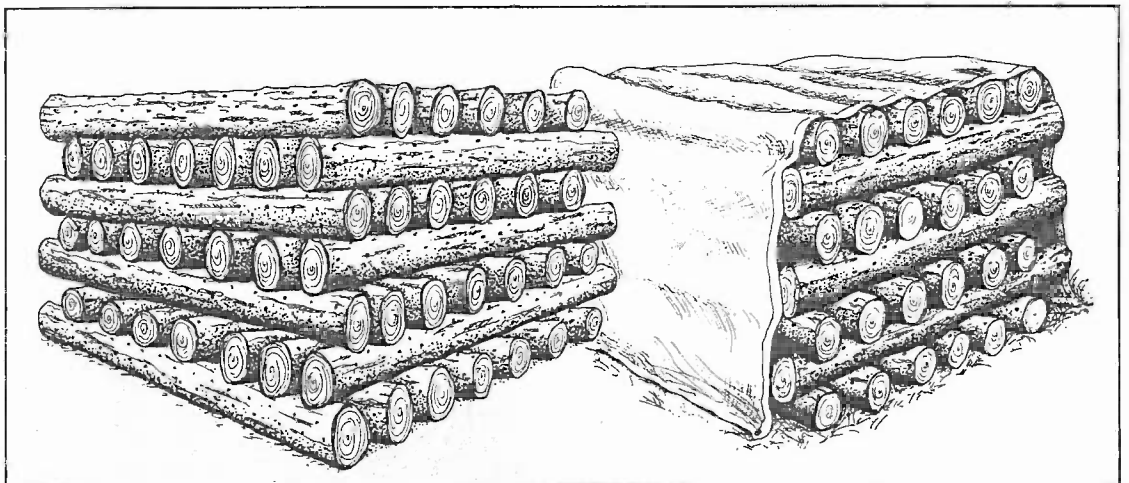

Figure 27. Inoculated logs are stacked and covered with a tarp.



Figure 28. *Gymnopilus spectabilis*, the Big Laughing Mushroom, fruiting from log inoculated with sawdust spawn via the wedge technique.

over the rapidly decomposing hardwoods with their paper-thin bark layers. The rapidly decomposing hardwoods like alder and birch are easily damaged by weather fluctuations, especially humidity. Should the bark layer fall from the log, the mycelium has difficulty supporting good mushroom flushes.

Logs are generally cut from trees in the spring, prior to leafing, when the sapwood still retains ample sugars. The logs, once felled, should be kept off the ground. Ideally inoculations should occur within 2 months of felling. (In temperate North America, February and March are ideal.)

Numerous methods can be used for inoculating the spawn into the log. Logs are usually pegged, i. e. drilled with holes and inoculated with plug or sawdust spawn. Most logs receive 30-50 plugs, which are inserted into evenly spaced holes (4-6 inches apart) arranged longi-



Figure 29. The Oyster mushroom (*Pleurotus ostreatus*) fruiting on alder logs that were inoculating via the wedge technique.



Figure 30. Oyster mushroom fruiting from alder logs inoculated via the spawn disc technique.

tudinally down the axis of the logs in a diamond pattern. By off-centering the rows of holes in a diamond pattern, the mycelium grows out to become one interconnected, macro-organism, after which synchron-ous fruitings can occur. Once inserted by hand, the plugs are pounded in with a rubber mallet or hammer. The plugged hole is covered with cheese-wax, usually painted on, to protect the mycelium from insect or weather damage.

Another method calls for the inoculation of logs by packing sawdust spawn into cuts made with a chain saw. A common technique is to cut a "V" shaped wedge from a log, pack the wound full of sawdust spawn, and press the wedge of wood back into place. Nailing the wedge back into position assures direct and firm contact. Another variation is to cut logs into 16 to 24 inch sections and sandwich spawn in between.

Sawdust spawn can be used in other ways. Newly cut ends of the logs can be packed with sawdust spawn and then capped with aluminum foil, or a "sock" to hold the mycelium in place. (San Antonio (1983) named this technique the *spawn disk* method.) Some prefer cutting wedges from the logs, and then repacking the cut wedge back into the log with mycelium sandwiched in between. Others cut the logs in sections, two feet in length, and pack the sawdust spawn in between the two sections, which are reattached by any means possible.

For anyone growing outdoors in climates with severe dry spells, or where watering is a problem, logs should be buried 1/3 to 1/4 of their length into the ground. The ground moisture will constantly replenish water lost through evaporation, lessening the effect of humidity fluctuation. This method is especially useful for the cultivation of Lion's Mane, Nameko, Oyster and Reishi. It is widely used by growers in China. Many cultivators protect their logs from

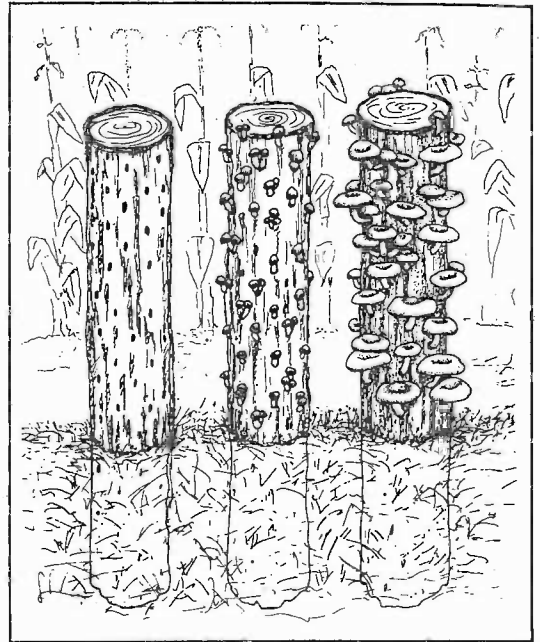

Figure 31. By burying the logs into the ground, sub-surface moisture is drawn up into the log, encouraging mushroom formation.

the sun by either locating them under a forest canopy or by rigging up a shade cloth.

Most log cultivators develop their own, unique techniques, dictated by successes and failures. Many books on log cultivation have been written, too numerous to list here. Two books on Shiitake log cultivation that I highly recommend for those who wish to study these techniques further are *Growing Shiitake Mushrooms in a Continental Climate* (2 ed.) by Mary Kozak & Joe Krawczyk and *Shiitake Grower's Handbook* by Paul Przybylowicz and John Donoghue. The methods described in these books can be extrapolated for the cultivation of other gourmet and medicinal mushrooms on logs.

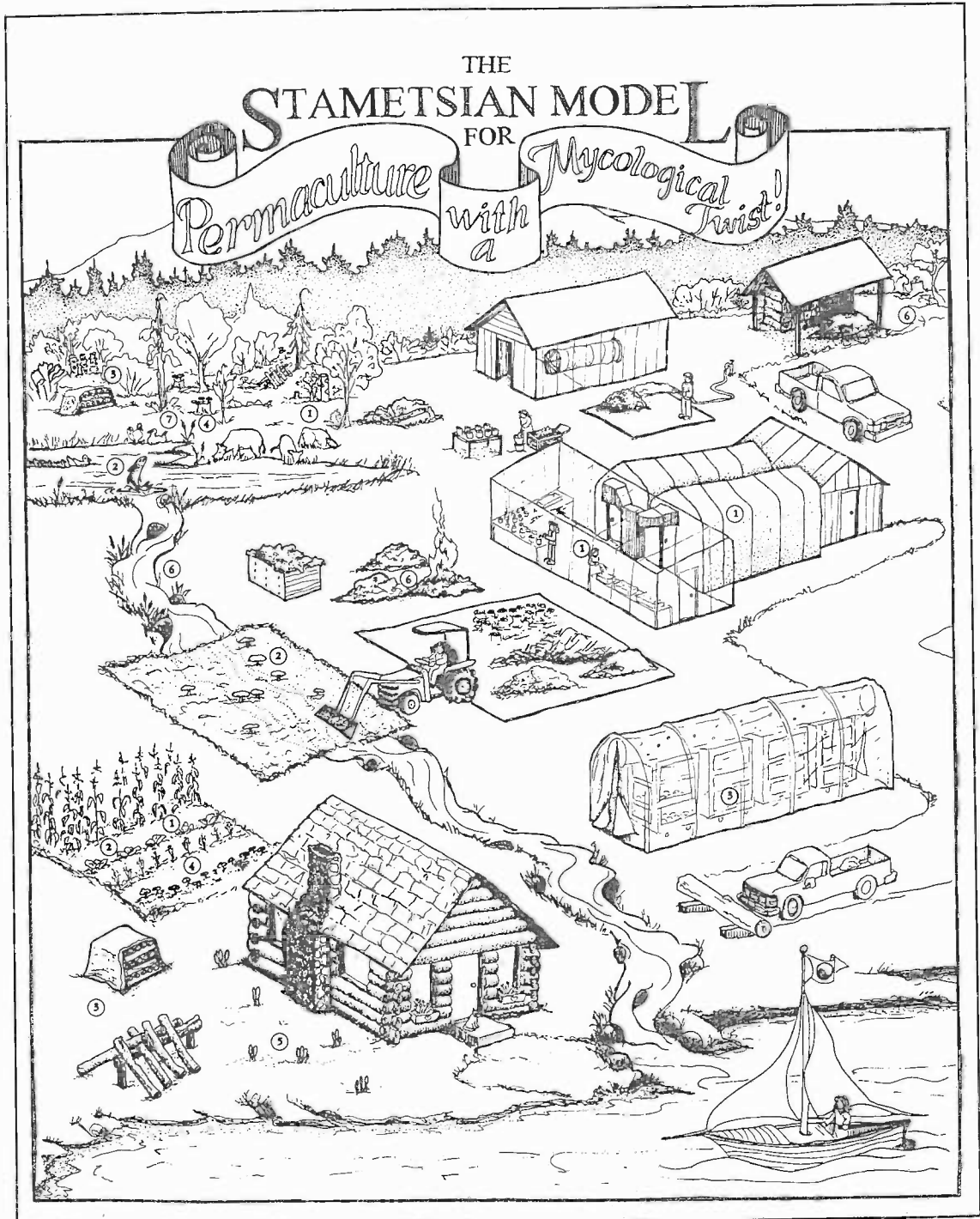

Figure 32. The Stametsian Model for Permaculture with a Mycological Twist.



# The Stametsian Model: Permaculture with a Mycological Twist

**P**ermaculture is a concept pioneered by Australian Bill Mollison and literally means “permanent agriculture.” His model of biological diversity and complementary agricultural practices promotes a sustainable environment via the interplay of natural ecosystems. Permaculture has gained a huge international following after the publication of his book *Permaculture: A Practical Guide for a Sustainable Future*. Permaculture has become the mainstay philosophy of the organic movement. Mollison’s vision, which borrows from Masanobu Fukuoka’s *One Straw Revolution*, intelligently combines the factors of site location, recycling of by-products from farming and forest activities, species diversity and biological succession.

When gourmet and medicinal mushrooms are involved as key organisms in the recycling of agricultural and forest by-products, the biodynamics of permaculture soar to extraordinary levels of productivity. Not only are mushrooms a protein-rich food source for humans, but the by-products of mushroom cultivation unlock nutrients for other members of the ecological community. The rapid return of nutrients back into the ecosystem boosts the life cycles of plants, animals, insects (bees), and soil microflora.

What follows is a short list of the ways mushrooms can participate in permaculture. The numbers are keyed to the numbers in the accompanying illustration: The Stametsian Model for Permaculture with a Mycological Twist.

**1. Oyster Mushrooms:** Oyster mushrooms can be grown indoors on pasteurized corn stalks, wheat, rice, and rye straw and a wide range of other materials including paper and pulp by-products. Soaking bulk substrates in cold water creates a residual "tea" that is a nutritious fertilizer and potent insecticide. Submerging the bulk substrate in hot water produces a different brew of "tea": a naturally potent herbicide. Oyster mushrooms can also be grown on hardwood stumps and logs. (Some varieties of Oyster mushrooms in the *P. pulmonarius* species complex naturally grow on conifer wood. ) *Pleurotus* spp. thrive in complex compost piles, and are easy to grow outside with minimum care. The waste substrate from Oyster production is useful as fodder for cows, chickens, and pigs. Since half of the mass of dry straw is liberated as gaseous carbon dioxide, pumping this CO<sub>2</sub> from mushroom growing rooms into greenhouses to enhance plant production makes good sense. (Cultivators filter the airstream from the mushroom growing rooms so spores are eliminated. ) Furthermore, the waste straw can be mulched into garden



Figure 33. Oyster mushrooms fruiting from a stump inoculated with sawdust spawn.

soils, not only to provide structure and nutrition, but also to reduce the populations of nematodes which are costly to gardeners and farmers.

**2. King Stropharia:** This mushroom is an ideal player in the recycling of complex wood debris and garden wastes, and thrive in complex environments. Vigorously attacking wood (sawdust, chips, twigs, branches), the King Stropharia also grows in wood-free substrates, particularly soils supplemented with chopped straw. I have seen this mushroom flourish in gardens devoid of wood debris, benefiting the growth of neighboring plants. Acclimated to northern latitudes, this mushroom fruits when air temperatures range between 60-90° F. (15-32° C.) which usually translates to ground temperatures of 55-65° F. (13-18° C.).

For 6 weeks one summer our bees attacked a King Stropharia bed, exposing the mycelium to



Figure 34. Honey bees suckling on the mycelium of *Stropharia rugoso-annulata*.

the air and suckling the sugar-rich cytoplasm from the wounds. A continuous convoy of bees could be traced, from morning to evening, from our beehives to the mushroom patch, until the bed of King Stropharia literally collapsed. When a report of this phenomenon was published in *Harrowsmith Magazine* (Ingle, 1988), bee keepers across North America wrote me to explain that they had been long mystified by bees' attraction to sawdust piles. Now it is clear the bees were seeking the underlying sweet mushroom mycelium.

King Stropharia is an excellent edible mushroom when young. However, its edibility quickly declines as the mushrooms mature. Fly larvae proliferate inside the developing mushrooms. In raising silver salmon, I found that when I threw mature mushrooms into the fish-holding tank, they would float. Fly larvae soon emerged from the mushrooms, struggling for

air. Soon the fish were striking the large mushrooms to dislodge the swollen larvae into the water where they were eagerly consumed. After several days of feeding mushrooms to the fish, the salmon would excitedly strike at the King Stropharia in anticipation of the succulent, squirming larvae as soon as the mushrooms hit the water. Inadvertently, I had discovered that King Stropharia is a good base medium for generating fish food.

Growing King Stropharia can have other beneficial applications in permaculture. King Stropharia depends upon bacteria for growth. At our farm, which included a small herd of Black Angus cows, I established two King Stropharia beds at the heads of ravines which drained onto a saltwater beach where my neighbor commercially cultivates oysters and clams. Prior to installing these mushroom beds, fecal coliform bacteria seriously threatened the water quality. Once the mycelium fully permeated the sawdust/chip beds, downstream fecal bacteria was largely eliminated. The mycelium, in effect, became a micro-filtration membrane. I had discovered that by properly locating mushroom beds, "gray water" run-off could be cleaned of bacteria and nitrogen-rich effluent. Overall water quality improved. Massive mushrooms formed. (See Figure 35.) After three to four years, chunks of wood are totally reduced into a rich, peat-like soil, ideal for the garden. For nearly 8 years I have continued to install King Stropharia beds in depressions leading into sensitive watersheds. Government agencies, typically slow to react to good ideas, have finally recognized the potential benefits of *mycofiltration*. Test plots are currently being implanted and monitored to more precisely determine the effects on water quality. If successful, I envision the widespread installation of King Stropharia beds into basins leading into



Figure 35. LaDena Stamets sitting amongst 5 lb. specimens of the King Stropharia, *Stropharia rugoso-annulata*.

rivers, lakes, and bodies of saltwater.

**3. Shiitake/Nameko/Lion's Manes:** Outdoors, inoculated logs can be partially buried or lined up in fence-like rows. Once the logs have stopped producing, the softened wood can be broken up, sterilized, and re-inoculated. Indoors, these mushrooms can be grown on sterilized substrates or on logs using the methods described in this book. Once the indoor substrates cease production, they can be recycled and re-inoculated with another mushroom, a process I call *species sequencing*. (See Chapter 22.) Later, the expired production blocks can be buried in sawdust or soil to to elicit bonus crops outdoors.

**4. Maitake/Reishi/Clustered Wood-lovers:** Several species can be incorporated into the management of a sustainable multi-stage, com-

plex Medicinal Mushroom Forest. Logs can be inoculated and buried or stumps can be impregnated. The greatest opportunities for stump culture are regions of the world where hardwoods predominate. Presently, only a few gourmet and medicinal mushrooms grow on coniferous woods. Nevertheless, Enokitake (*Flammulina velutipes*), Reishi (*Ganoderma lucidum*), Clustered Woodlovers (*Hypholoma capnoides*), Chicken-of-the-Woods (*Laetiporus sulphureus*), and Oyster (*Pleurotus* spp.) are good candidates for both conifer and hardwood stump decomposition.

**5. Shaggy Manes:** A cosmopolitan mushroom, Shaggy Manes (*Coprinus comatus*) grow in rich manured soils, disturbed habitats, in and around compost piles, and in grassy and gravelly areas. Shaggy Manes are extremely adaptive and tend to wander. Shaggy Mane



Figure 36. 3 lb. specimen of King Stropharia lounging.

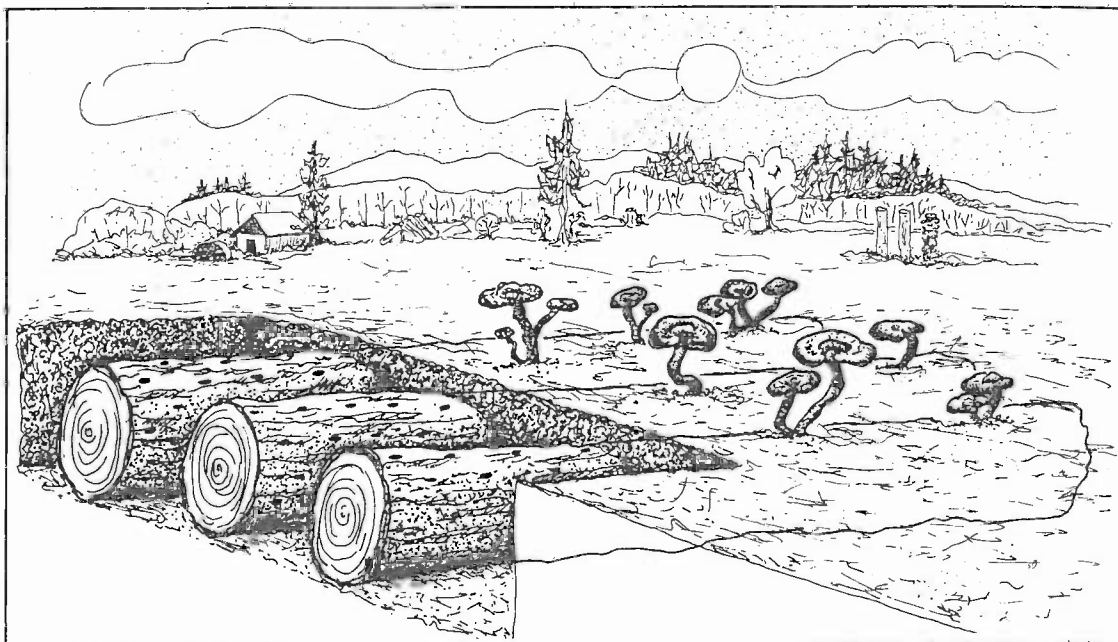

Figure 37. Mushrooms, in this case Reishi (*Ganoderma lucidum*), can be grown on logs buried into sawdust or gravel.

patches behave much like King Stropharia and Morels, travelling great distances from their original site of inoculation in their search for fruiting niches.

**6. Morels:** Morels grow in a variety of habitats, from abandoned apple orchards and diseased elms to gravelly roads and stream beds. However, the habitat that can be reproduced easily is the burn-site. (See page 401 for techniques on Morel cultivation.) Burn-sites, although increasingly restricted because of air pollution ordinances, are common among country homesteads. If a burn-site is not possible, there are alternatives. The complex habitat of a garden compost pile also supports Morel growth. When planting cottonwood trees, you can introduce spawn around the root zones in hopes of creating a perennial Morel patch. Cultivators should note that Morels are fickle and elusive by nature

compared to more predictable species like King Stropharia, Oyster and Shiitake mushrooms.

**7. Mycorrhizal Species:** Mycorrhizal species can be introduced via several techniques. The age-old, proven method of satellite planting is probably the simplest. By planting young seedlings around the bases of trees naturally producing Chanterelles, King Boletes, Matsutake, Truffles or other desirable species, you may establish satellite colonies by replanting the young trees after several years of association. For those landowners who inherit a monoculture woodlot of similarly aged trees, the permaculturally inclined steward could plant a succession of young trees so that, over time, a multi-canopied forest could be re-established.

**8. The Sacred Psilocybes:** In the Pacific Northwest of North America, the Psilocybes figure as some of the most frequently found

fungi in landscaping bark and wood chips. These mushrooms share a strong affinity towards human activities—from chopping wood, the planting of ornamentals, landscaping around buildings, to the creation of refuse piles. Many spiritually inclined cultivators view the establishment of *Sacred Psilocybe Mushroom Patches* as another step towards living in harmony within their ecosystem.

These are but a few of the mushroom species that can be incorporated into the permaculture model. Part of a larger, community-based

permaculture strategy should also include *Mushroom Response Teams* (MRT's) which could react quickly to catastrophic natural disasters—such as hurricanes, tornadoes, floods—in the profitable recycling of the enormous debris fields they generate.

Clearly, the use of mushrooms raises permaculture to a level otherwise not attainable. I hope readers will develop such concepts further. When fungi are incorporated into these models, the ecological health of the whole planet will benefit enormously.

---

# Materials for Formulating a Fruiting Substrate

**T**he potential for recycling organic wastes with fungi seems unlimited. Surprisingly, many mushrooms thrive on base materials alien to their natural habitat. Although Oyster mushrooms are generally found in the wild on deciduous woods, they grow well on many other materials besides hardwoods, including cereal straws, corn cobs, seed hulls, coffee wastes, sugar cane bagasse, paper and pulp by-products, and numerous other materials.

Success increases if the base material is modified to create an optimal structure and moisture—and heat-treated—before inoculation. The fact that many mushrooms can cross over to other non-native substrates gives the cultivator tremendous latitude in designing habitats.

Materials for composing a mushroom substrate are diverse and plentiful. Because fungi decompose plant tissue, most homeowners can use by-products generated from gardening, landscaping, tree pruning and even building projects. Homeowners who collect and pile

these debris have a perfect opportunity for growing a variety of gourmet and medicinal mushrooms. If a mushroom of choice is not introduced, a wild species from the natural environment will invade. The probability that one of these invading wild mushrooms would be a gourmet species is remote.

I prefer sawdust and wood debris as primary substrate components. Deciduous woods, especially those which decompose quickly, are the best. These fast-rotting woods, being less able to resist disease, accelerate the mushroom life cycle. Alder, cottonwood and poplar are favored over the more resistant, denser woods such as the oaks, maples, or ironwoods. Once the wood sawdust is gathered, additional materials are added to fortify the substrate. Three additional factors affect the suitability of a mushroom habitat: *structural composition, pH* and *moisture*.

The selection of the substrate components is more critical for growing gourmet mushrooms indoors than for growing outdoors. Commercial cultivators prefer the controlled conditions of indoor cultivation whereas most home cultivators are attracted to outdoor natural culture. Outdoor mushroom beds can be more complex, composed of crude mixtures of components, whereas for indoor cultivation, the uniformity and consistency of the substrate is essential.

## Raw Materials

Most by-products from agriculture and forestry industries can make up a base medium for mushroom culture. This base medium is commonly referred to as the "fruiting substrate". This primary material is often supplemented with a carbohydrate- and protein-rich additive to enhance yields. Here is a short list of the materials that can be recycled into mushroom production.

*Wood wastes, paper products*

*Cereal straws & grain hulls*

*Corn cobs*

*Coffee plants & waste*

*Tea leaves*

*Sugar cane bagasse*

*Banana fronds*

*Seed hulls (cottonseed and oil-rich seeds)*

*Hulls of almonds, walnuts, sunflower, pecans, and peanuts*

*Soybean meal, roughage (Okara) & soy waste*

*Artichoke waste*

*Cactus waste: saguaro & prickly pear, yucca, agave\**

## Suitable Wood Types: Candidate Tree Species

A vast variety of woods can be used for growing gourmet and medicinal mushrooms. Generally speaking, the hardwoods are more useful than the softwoods. Several wood types may not perform by themselves, but when combined with more suitable woods—and boosted with a nutritional supplement—will give rise to commercially viable crops. Recommended hardwoods are alders, birches, hornbeams, chestnuts, chinkapins, beeches, ashes, larches, sweetgums, tanoaks, cottonwoods, willows, ironwoods, walnuts, elms, and similar woods. Suggested softwoods are Douglas firs and hemlocks. Most other pines (ponderosa, lodgepole), cedars, and redwood are not easily degraded by mushroom mycelium. Aromatic hardwoods, such as eucalyptus, are not recommended until we better understand why some people become ill from eating otherwise edible mush-

\* An Oyster mushroom, *Pleurotus opuntiae*, is native to prickly pear, agave and yucca. Although I have not cultivated Oyster mushrooms on these cacti, they should serve well as a substrate base.



rooms growing from this source. (Arora, 1990.) Cedars and redwoods are likewise not recommended as they decompose slowly due to their anti-rotting compounds. Obviously, these same compounds stifle the growth of mushroom mycelium.

Other woods than those listed may prove to be satisfactory. Hence, experimentation is strongly encouraged. I find that the fast-growing, rapidly decomposing hardwoods are generally the best because they have greater ratios of starch-enriched sapwood to heartwood. These sugars encourage rapid initial growth, resulting in full colonization in a short period of time. *The key to successful cultivation is to match the skills of the cultivator with the right strain on the proper substrate under ideal environmental conditions.*

For outdoor log culture, disease-free logs should be selected from the forest in the winter or early spring. If you use sawdust and chips for indoor or outdoor cultivation, freshness counts—or else competitors may have already taken hold. Lumber mills, pulp mills, furniture manufacturers, and many other wood product companies generate waste usable to the mushroom cultivator. However, those industries which run mixed woods and do not separate their sawdust into identifiable piles, are not recommended as substrate suppliers. Cultivators face enough problems in their struggle to understand the different yields of each crop cycle. Hence, mixed wood sources are best avoided, if possible.

Red alder (*Alnus rubra*) is a “weed tree” in western Washington State of North America. Like poplars and cottonwoods, its penchant for valleys, wetlands and open habitats encourages a prodigious growth rate. Many of these trees are common along roads where they foul telephone and electrical lines. A whole industry has arisen dedicated to rendering these trees into

chips, a fortuitous situation for mushroom cultivators. A matrix of smaller and larger particles can be combined to create an ideal habitat for mycelium. The smaller particles stimulate quick growth (“leap-off”). The larger particles encourage the mycelium to form thick, cord-like strands, called rhizomorphs, which forcibly penetrate through and between the cells. The larger chips become nutritional bases, *fruiting platforms*, giving rise to super-large mushrooms. This concept has been an overriding influence, steering my methods, and has resulted, for instance, in the large 5 lb. specimens of *Stropharia rugoso-annulata*, the Garden Giant, that is pictured in this book. A simple 50:50 mixture (by volume) of sawdust and chips, of varying particle sizes, provides the best structure for the mushroom habitat. The substrate matrix concept will be explored in greater detail later on.

Cultivators should avoid wood chips originating from trees along busy roadways. Automobile exhaust and leachate from the oil-based asphalt contaminate the surrounding soil with toxins, including lead and aluminum. Metals can be concentrated by the mushroom mycelium and transferred to the mushrooms. Wood chips from county roads with little traffic are less prone to this heavy metal contamination. This problem is largely circumvented by obtaining sawdust and chips from larger diameter trees. Sawmills and pulp chip companies provide the cleanest source of wood debris for substrate preparation.

Currently, the heavy metal concentrations taken up by mushrooms are well below the standards set by the United States government for fish, for instance. However, air pollution is a growing concern. My analyses of mushrooms grown in China, California, and Washington state revealed that the Chinese mushrooms had

the greatest aluminum, mercury & lead concentrations, with Californian mushrooms next, and mushrooms grown in the less industrialized Olympic Peninsula of Washington had the least. With the phasing out of lead-based gasoline and the implementation of tougher environmental restrictions, pollution of wood sources may be ameliorated. (For more information on the concentration of metals and toxins, and their potential significance, consult Stijve, 1992 &

Mushroom News, Dec., 1992). Many environmental service companies will analyze your product for a nominal fee, usually between \$ 50-125 U. S. If an analysis shows unusually high levels, the same specimens should be sent to an unrelated laboratory for confirmation. Please consult your Department of Agriculture, county extension agent or comparable agency for any applicable threshold requirements.

### List of Suitable Tree Species for the Cultivation of Gourmet & Medicinal Mushrooms\*

Scientific Name	Common Name	Scientific Name	Common Name
<b>Abies spp.</b>	<b>Red Fir</b>	<i>Alnus tinctoria</i>	
<i>Abies alba**</i>	White Fir	<i>Altingia chinensis</i>	
<b>Acer spp.</b>	<b>Maples</b>	<b>Arbutus spp.</b>	<b>Madrones</b>
<i>Acer negundo</i>	Box Elder	<i>Arbutus menziesii</i>	<i>Pacific Madrone</i>
<i>Acer rubrum</i>	Red Maple	<b>Betula spp.</b>	<b>Birches</b>
<i>Acer macrophyllum</i>	Big Leaf Maple	<i>Betula alleghaniensis</i>	Yellow Birch
<i>Acer saccharum</i>	Sugar Maple	<i>Betula dahurica</i>	
<i>Alniphyllum fortunei</i>		<i>Betula lenta</i>	Sweet Birch
<b>Alnus spp.</b>	<b>Alders</b>	<i>Betula nigra</i>	River Birch
<i>Alnus alba</i>	White Alder	<i>Betula papyrifera</i>	Paper Birch
<i>Alnus glutinosa</i>	European Alder	<i>Betula pendula</i>	European Birch
<i>Alnus incana</i>	Gray Alder	<i>Betula pubescens</i>	Hairy Birch
<i>Alnus japonica</i>	Japanese Alder	<b>Carpinus</b>	<b>Hornbeans</b>
<i>Alnus rubra</i>	Red Alder	<i>Carpinus betulis</i>	European Hornbean
<i>Alnus serrulata</i>	Hazel Alder	<i>Carpinus caroliniana</i>	American Hornbean

\* This list was compiled from trials and reports by the author, Pagony (1973), San Antonio (1981), Farr (1983), Gilbertson & Ryvardeen (1986), and Chang & Miles (1989), Przybylowicz & Donoghue (1989), and Kruger (1992). Some of the listed tree species are probable candidates due to their close affinities to species proven to be suitable for cultivation. I do not encourage the cutting of trees solely as a source of substrate for mushroom cultivation. The acquisition of wood materials from the forest should follow sustainable forest practices, and ide-

ally be a "waste" product generated from other activities.

\*\*Some races of *Ganoderma* (*G. oregonense* & *G. tsugae*), *Hypholoma* (*H. capnoides*), *Pleurotus* (*P. pulmonarius*), *Psilocybe* (*P. cyanescens* and allies) and *Stropharia* (*S. rugoso-annulata*) grow naturally on firs (i.e. *Abies* species). In general, these conifer-degrading mushroom species can also be cultivated on most hardwoods. However, few mushroom species native to hardwoods will fruit on most conifers.

Scientific Name	Common Name	Scientific Name	Common Name
<i>Carpinus fargesii</i>		<b>Corylus spp.</b>	<b>Filberts</b>
<i>Carpinus japonica</i>	Japanese Hornbeam	<i>Corylus heterophylla</i>	
<i>Carpinus laxiflora</i>		<i>Distylium myricoides</i>	
<i>Carpinus tschonoskii</i>		<i>Distylium racemosum</i>	
<i>Carpinus turczaninowii</i>		<i>Elaeocarpus chinensis</i>	
<b>Carya spp.</b>	<b>Hickories</b>	<i>Elaeocarpus japonicus</i>	
<i>Carya aquatica</i>	Water Hickory	<i>Elaeocarpus lancaefolius</i>	
<i>Carya cordiformis</i>	Bitternut Hickory	<i>Engelhardtia chrysolepis</i>	
<i>Carya glabra</i>	Pignut Hickory	<i>Eriobotrya deflexa</i>	
<i>Carya texana</i>	Black Hickory	<i>Euphorbia royleana</i>	
<i>Carya illinoensis</i>	Pecan	<i>Eurya loquiana</i>	
<i>Carya laciniosa</i>	Shellbark Hickory	<b>Fagus spp.</b>	<b>Beeches</b>
<i>Carya tomentosa</i>	Mockernut Hickory	<i>Fagus crenata</i>	
<i>Carya ovata</i>	Shagbark Hickory	<i>Fagus grandifolia</i>	American Beech
<b>Castanea spp.</b>	<b>Chestnuts</b>	<b>Fraxinus spp.</b>	<b>Ashes</b>
<i>Castanea crenata</i>	Japanese Chestnut	<i>Fraxinus americana</i>	White Ash
<i>Castanea henryi</i>		<i>Fraxinus latifolia</i>	Oregon Ash
<i>Castanea mollissima</i>		<i>Fraxinus nigra</i>	Black Ash
<i>Castanea sativa</i>	Spanish Chestnut	<i>Fraxinus pennsylvanica</i>	Green Ash
<i>Castanea sequinii</i>		<i>Fraxinus velutina</i>	Velvet Ash
<b>Castanopsis spp.</b>	<b>Chinkapins</b>	<b>Juglans spp.</b>	<b>Walnut</b>
<i>Castanopsis</i>		<i>Juglans nigra</i>	Black Walnut
<i>accuminatissima</i>		<b>Larix spp.</b>	<b>Larches</b>
<i>Castanopsis argentea</i>		<i>Larix laricina</i>	Larch
<i>Castanopsis cerlesii</i>		<i>Larix lyalli</i>	Subalpine Larch
<i>Castanopsis chinensis</i>		<i>Larix occidentalis</i>	Western Larch
<i>Castanopsis chrysophylla</i>	Golden Chinkapin	<b>Liquidambar spp.</b>	<b>Sweetgums</b>
<i>Castanopsis cuspidata</i>	Shii Tree	<i>Liquidambar formosana</i>	
<i>Castanopsis fabri</i>		<i>Liquidambar styraciflua</i>	
<i>Castanopsis fargesii</i>		<i>Liriodendron tulipifera</i>	Tulip Poplar
<i>Castanopsis fissa</i>		<b>Lithocarpus spp.</b>	<b>Tanoaks</b>
<i>Castanopsis fordii</i>		<i>Lithocarpus auriculatus</i>	
<i>Castanopsis hickelii</i>		<i>Lithocarpus calophylla</i>	
<i>Castanopsis hystrix</i>		<i>Lithocarpus densiflorus</i>	
<i>Castanopsis indica</i>		<i>Lithocarpus glaber</i>	
<i>Castanopsis lamontii</i>		<i>Lithocarpus lanceaefolia</i>	
<i>Castanopsis sclerophylla</i>		<i>Lithocarpus lindleyanus</i>	
<i>Castanopsis tibetana</i>		<i>Lithocarpus polystachyus</i>	
<b>Cornus spp.</b>	<b>Dogwoods</b>	<i>Lithocarpus spicatus</i>	
<i>Cornus capitata</i>	Flowering Dogwood	<i>Mallotus lianus</i>	
<i>Cornus florida</i>	Flowering Dogwood		
<i>Cornus nuttallii</i>	Pacific Dogwood		

Scientific Name	Common Name	Scientific Name	Common Name
<b>Ostrya spp.</b>	<b>Ironwoods (Hophornbeam)</b>	<i>Quercus lyrata</i>	Overcup Oak
<i>Ostrya carpinifolia</i>		<i>Quercus michauxii</i>	Swamp Chestnut Oak
<i>Ostrya virginiana</i>		<i>Quercus mongolica</i>	
<b>Pasania</b>		<i>Quercus muehlenbergii</i>	
<i>Platycarya strobilacea</i>		<i>Quercus myrsinae</i>	
<b>Populus spp.</b>	<b>Cottonwoods &amp; Poplars</b>	<i>Quercus nigra</i>	Water Oak
<i>Populus balsamifera</i>	Balsam Poplar	<i>Quercus nuttalli</i>	
<i>Populus deltoides</i>	Eastern Cottonwood	<i>Quercus palustris</i>	Pin Oak
<i>Populus fremontii</i>	Fremont Cottonwood	<i>Quercus phellos</i>	Willow Oak
<i>Populus grandidentata</i>	Bigtooth Aspen	<i>Quercus prinus</i>	
<i>Populus heterophylla</i>	Swamp Cottonwood	<i>Quercus rubra</i>	Northern Red Oak
<i>Populus nigra</i>	Black Poplar	<i>Quercus semiserrata</i>	
<i>Populus tremuloides</i>	Quaking Aspen	<i>Quercus serrata</i>	
<i>Populus trichocarpa</i>	Black Cottonwood	<i>Quercus spinosa</i>	
<b>Prosopis spp.</b>	<b>Mesquite</b>	<i>Quercus variabilis</i>	
<i>Prosopis juliflora</i>	Honey Mesquite	<i>Quercus virginiana</i>	Live Oak
<i>Prosopis pubescens</i>	Screw Pod Mesquite	<b>Rhus spp.</b>	
<b>Quercus spp.</b>	<b>Oaks</b>	<i>Rhus glabra</i>	Sumac
<i>Quercus acuta</i>		<i>Rhus succedanea</i>	
<i>Quercus acutissima</i>		<b>Robinia spp.</b>	<b>Black Locust</b>
<i>Quercus agrifolia</i>	California Live Oak	<i>Robinia neomexicana</i>	New Mexico Black Locust
<i>Quercus alba</i>	White Oak	<i>Robinia pseudoacacia</i>	Black Locust
<i>Quercus aliena</i>		<b>Salix spp.</b>	<b>Willows</b>
<i>Quercus bella</i>		<i>Salix amygdaloides</i>	Peachleaf Willow
<i>Quercus brandisiana</i>		<i>Salix exigua</i>	Sandbar or Coyote Willow
<i>Quercus chrolepis</i>	Canyon Live Oak	<i>Salix fragilis</i>	Crack Willow
<i>Quercus crispula</i>		<i>Salix geyerana</i>	Geyer Willow
<i>Quercus dentata</i>		<i>Salix lasiandra</i>	Pacific Willow
<i>Quercus emoryi</i>	Emory Oak	<i>Salix lasiolepis</i>	Arrow Willow
<i>Quercus fabri</i>		<i>Salix nigra</i>	Black Willow
<i>Quercus falcata</i>	Southern Red Oak	<i>Salix scoulerana</i>	Scouler Willow
<i>Quercus gambelii</i>	Gambel Oak	<i>Sapium discolor</i>	
<i>Quercus garryana</i>	Oregon White Oak	<i>Sloanea sinensis</i>	
<i>Quercus glandulifera</i>		<b>Taxus spp.</b>	<b>Yews</b>
<i>Quercus glauca</i>		<i>Taxus brevifolia</i>	Pacific Yew
<i>Quercus grosseserrata</i>		<b>Ulmus spp.</b>	<b>Elms</b>
<i>Quercus kelloggii</i>	California Black Oak	<i>Ulmus americana</i>	American Elm
<i>Quercus kerii</i>		<i>Ulmus campestris</i>	English Elm
<i>Quercus kingiana</i>		<i>Ulmus laevis</i>	Fluttering Elm
<i>Quercus lobata</i>	California White Oak	<i>Ulmus montana</i>	Mountain Elm
<i>Quercus laurifolia</i>	Laurel Oak		

**Cereal Straws** For the cultivation of Oyster mushrooms, cereal straws rank as the most usable base material. Wheat, rye, oat and rice straw perform the best. Of all the straws, I prefer wheat. Inexpensive, readily available, preserving well under dry storage conditions, wheat straw admits few competitors. Furthermore, wheat straw has a nearly ideal shaft diameter which selectively favors the filamentous cells of most mushrooms. Chopped into 1-4 inch lengths, the wheat straw needs only to be pasteurized by any one of several methods. The approach most easily used by home cultivators is to submerge the chopped straw into hot water (160° F., 71° C.) for 1-2 hours, drain, and inoculate. First, fill a metal barrel with hot tap water and place a propane burner underneath. (Drums should be food grade quality. Do not use those that have stored chemicals.) A second method calls for the laying of straw onto a cement slab or plastic sheeting to a depth of no more than 24 inches. The straw is wetted and turned for 2-4 days, and then loaded into a highly insulated box or room. Steam is introduced, heating the mass to 160° F. (71° C.) for 2-4 hours. (See Chapter 18 for these methods.)

The semi-selectivity of wheat straw, especially after pasteurization, gives the cultivator a two-week "window of opportunity" to establish the gourmet mushroom mycelium. Wheat straw is one of the most forgiving substrates with which to work. Outdoor inoculations of pasteurized wheat straw with grain spawn, even when the inoculations take place in the open-air, have a surprisingly high rate of success for home cultivators.

Rye straw is similar to wheat, but coarser. Oat and rice straw are finer than both wheat and rye. The final structure of the substrate depends upon the diameter and the length of each straw shaft. Coarser straws result in a



Figure 38. Oyster mushrooms growing from my previous book, *The Mushroom Cultivator*.

looser substrate whereas finer straws create a denser or "closed" substrate. A cubic foot of wetted straw should weigh around 20-25 lbs. Substrates with lower densities tend to perform poorly. The cultivator must design a substrate which allows air-exchange to the core. Substrate dynamics are determined by a combination of all these variables.

**Paper Products (Newspaper, Cardboard, Books, etc.)** Using paper products as a substrate base is particularly attractive to those wishing to grow mushrooms where sawdust supplies are limited. Tropical islands and desert communities are two examples. Paper products are made of pulped wood, (lignin-cellulose fibers), and therefore support most wood-decomposing mushrooms. In recent years, most printing companies have switched to soybean-based inks, reducing or almost eliminating toxic residues. Since many large newspapers are

recycling, data on toxin residues is readily available. (If the data can not be validated, or is outdated, the use of such newsprint is not recommended.) Since the use of processed wood fiber may disqualify a grower for state organic certification, cultivators in the United States should check with their Organic Certification Director or with their State Department of Agriculture before venturing into the commercial cultivation of gourmet mushrooms on paper-based waste products. If these preconditions can be satisfied, the would-be cultivator can tap into an enormous stream of cheap materials suitable for substrate composition.

**Corncobs & cornstalks** Corncobs (*sans* kernels) and cornstalks are conveniently structured for rapid permeation by mycelium. Their cell walls and seed cavities provide a uniquely attractive environment for mycelium. Although whole corncobs can be used directly, a more uniform substrate is created by grinding of corncobs to 1-3 inch particles using hammer-mill type chipper-shredders. After moistening, the corn roughage can be cooked for 2-4 hours at 160-180° F. to achieve pasteurization. If the kernels are still on the cob, sterilization may be necessary. Cornstalks, having a lower nutritional content, are less likely to contaminate.

**Coffee & banana plants** In the subtropical and tropical regions of Central and South America, the abundance of coffee and banana leaves has spurred mycologists to examine their usefulness in growing gourmet mushrooms. The difficulty in selecting any single plant material from warm, humid regions is the speed of natural decomposition due to competitors. The combination of high humidity and heat accelerates decomposition of everything biodegradable. Leaves must be dried, shredded, and stored in a

manner *not* to encourage composting. Once weed fungi, especially black and green molds, begin to proliferate the suitability of these base materials is jeopardized. At present, the only mushrooms demonstrating commercial yield efficiencies on banana and coffee pulp are warm-weather strains of Oyster mushrooms, particularly *Pleurotus citrinopileatus*, *Pleurotus cystidiosus*, *Pleurotus djamor*, *Pleurotus ostreatus* and *Pleurotus pulmonarius*. For more information on the cultivation of Oyster mushrooms on coffee waste, please refer to Thielke (1989), or Martinez-Carrera (1987).

**Sugar cane bagasse** Sugar cane bagasse is the major waste product recovered from sugar cane harvesting and processing. Widely used in Hawaii and the Phillipines by Oyster growers, sugar cane bagasse needs only pasteurization for cultivating Oyster mushrooms. Some Shiitake strains will produce on sugar cane residue, but yield efficiencies are low compared to wood-based substrates. Since the residual sugar stimulates mycelial growth and is a known trigger to fruiting, sugar cane residues are good complements to wood-based substrates.

**Seed hulls** Seed hulls, particularly cottonseed hulls, are perfect for their particle size and their ability to retain water. Buffered with 5-7% calcium sulfate and calcium carbonate, cottonseed hulls simply need wetting, pasteurization and inoculation. Cottonseed hulls, on a dry weight basis, are richer in nitrogen than most cereal straws. Many Button cultivators consider cottonseed hulls a supplement to their manure-based composts. On unamended seed hulls, Oyster and Paddy Straw are the best mushrooms to grow.

Peanut shells have had little or no value except, until now, to mushroom growers. The peanut hulls are rich in oils and starch which stimulate mushroom growth. The shells must be chipped into 1/4 to 3/4 inch pieces, wetted, and

pasteurized for several hours. Because peanut shells form subterraneously and are in ground contact, they should be thoroughly washed before pasteurization. Sterilization may be required if pasteurization is insufficient. The addition of 5% gypsum (calcium sulfate) helps keep the substrate loose and aerated. Oyster mushrooms, in particular, thrive on this material.

**Soybean roughage (Okara)** Okara is the main by-product of tofu and tempeh production. Essentially the extracted roughage of boiled soybean mash, Okara is perfectly suited for quick colonization by a wide variety of mushrooms, from the *Pleurotus* species to *Ganoderma lucidum*, even Morels. Several companies currently use Okara for generating mycelium for extraction and/or for flavorings.

All of the above-mentioned materials can be used to construct a base for mushroom production, outdoors or indoors. A more expansive list could include every primary by-product from agricultural and forestry practices. To the imaginative cultivator, the resources seem almost limitless.

## Supplements

Supplementing the substrate can boost yields. A wide variety of protein-rich (nitrogenous) materials can be used to enhance the base substrate. Many of these are grains or their derivatives, like rice, wheat or oat bran, ground corn, etc. Supplementing a substrate, such as straw or sawdust, changes the number and the type of organisms that can be supported. Most of the raw materials used for growing the mushrooms listed in this book favor mushroom mycelium and are nitrogen-poor. Semi-selectivity is lost after nitrogen supplements are added, but ultimately mushroom yields improve. Therefore, when supplements are used, extra care is required to discourage contamination and insure success. Here good hygiene and good flow pat-

terns to, from and within the growing rooms are crucial. Supplementation of outdoor beds risks competition from contaminants and insects.

If supplementing a substrate, the sterilization cycle should be prolonged. Sterilization must be extended from 2 hours for plain sawdust at 15 psi to 4 hours for the same sawdust supplemented with 20% rice bran.

Supplemented sawdust, straw and compost substrates undergo *thermogenesis*, a spontaneous temperature increase as the mycelium and other organisms grow. If this naturally occurring biological combustion is not held in check, a plethora of molds awaken as the substrate temperature approaches 100° F. (38° C.). Below this threshold level, these organisms remain dormant, soon being consumed by the mushroom mycelium. Although true sterilization has not been achieved, full colonization is often times successful because the cultivator offsets the upward spiral of temperature. Simply spacing spawn bags or jars apart from one another, and lowering spawn room temperatures as thermogenesis begins, can stop this catalytic climb. For many of the gourmet wood decomposers, a temperature plateau of 75-85° F. (24-29° C.) is ideal.

The following supplements can be added at various percentages of total dry mass of the bulk substrate to enhance yields.

*corn meal*  
*cottonseed meal or flour*  
*oat bran, oat meal*  
*rice bran*  
*rye grain*  
*soybean meal & oil*  
*spent grains from beer fermentation*  
*(barley & wheat)*  
*vegetable oils*  
*wheat grain, wheat bran*  
*nutritional yeast*

The nutritional composition of these supple-

ments and hundreds of others are listed in Appendix V. Using rice bran as a reference standard, the substitution of other supplements should be added according to their relative protein and nitrogen contents. For instance, rice bran is approximately 12.5% protein and 2% nitrogen. If soybean meal is substituted for rice bran, with its 44% protein and 7% nitrogen content, the cultivator should add roughly 1/4 as much to the same supplemented sawdust formula. Until performance is established, the cultivator is better off erring on the conservative side than risking over-supplementation.

A steady supply of supplements can be cheaply obtained by recycling bakery waste, especially stale breads. A number of companies transform bakery by-products into a pelletized cattle feed, which also work well as inexpensive substitutes for many of the additives listed above.

## Structure of the Habitat

Whichever materials are chosen for making up the substrate base, particular attention must be given to *structure*. Sawdust is uniform in particle size but is not ideal for growing mushrooms by itself. Fine sawdust is "closed" which means the particle size is so small that air spaces are soon lost due to compression. Closed substrates tend to become anaerobic and encourage weed fungi to grow.

Wood shavings have the opposite problem of fine sawdust. They are too fluffy. The curls have large spaces between the wood fibers. Mycelium will grow on shavings, but too much cellular energy is needed to generate chains of cells to bridge the gaps between one wood curl and the next. The result is a highly dispersed, cushion-like substrate capable of supporting vegetative mycelium, but incapable of generating mushrooms since substrate mass lacks density.

The ideal substrate structure is a mix of fine

and large particles. Fine sawdust particles encourage mycelia to grow quickly. Interspersed throughout the fine sawdust should be larger wood chips (1-4 inches) which figure as concentrated islands of nutrition. Mycelium running through sawdust is often wispy in form until it encounters larger wood chips, whereupon the mycelium changes and becomes highly aggressive and rhizomorphic as it penetrates through the denser woody tissue. *The structure of the substrate affects the design of the mycelium network as it is projected.* From these larger island-like particles, abundant primordia form and can enlarge into mushrooms of great mass.

For a good analogy for this phenomenon, think of a camp fire or a wood stove. When you add sawdust to a fire, there is a flare of activity which soon subsides as the fuel burns out. When you add logs or chunks of wood, the fire is sustained over the long term. Mycelium behaves in much the same fashion.

Optimizing the structure of a substrate is essential for good yields. If you are just using fine sawdust and wood chips (in the 1-4 inch range) then mix 2 units of sawdust to every 1 unit of wood chips (by volume). (Garden shredders are useful in reducing piles of debris into the 1-4 inch chips.)

Although homogeneity in particle size is important at all stages leading up to and through spawn generation, the fruitbody formation period benefits from having a complex mosaic of substrate components. A direct relationship prevails between complexity of habitat structure and health of the resulting mushroom bed.

A good substrate can be made up of woody debris, chopped corncobs and cornstalks, stalks of garden vegetables, vines of berries or grapes. When the base components are disproportionately too large or small, without connective particles, then colonization by the mushroom mycelium is hindered.



## Biological Efficiency: An Expression of Yield

**M**ushroom strains vary in their ability to convert substrate materials into mushrooms as measured by a simple formula known as the “Biological Efficiency (B. E.) Formula” originally developed by the White Button mushroom industry. This formula states that

- 1 lb. of fresh mushrooms grown from 1 lb. of dry substrate is 100% biological efficiency.

Considering that the host substrate is moistened to approximately 75% water content and that most mushrooms have a 90% water content at harvest, 100% B. E. is also equivalent to

- growing 1 lb. of fresh mushrooms for every 4 lbs. of moist substrate, a 25% conversion of wet substrate mass to fresh mushrooms or
- achieving a 10% conversion of dry substrate mass into dry mushrooms.

Many of the techniques described in this book will give yields substantially higher than 100% B. E. Up to 1/2 conversion of wet substrate mass into harvestable mushrooms is possible. (I have succeeded in obtaining such yields with sets of Oyster, Shiitake, and Lion's Mane. Although 250% B. E. is exceptional, a good grower should operate within the 75-125% range.) Considering the innate power of the mushroom mycelium to transform waste products into highly marketable delicacies, it is understandable why scientists, entrepreneurs, and ecologists are awestruck by the prospects of recycling with mushrooms.

Superior yields can be attained by carefully following the techniques outlined in this book, paying strict attention to detail, and matching these techniques with the right strain. The best way to improve yields is simply to increase the spawn rate. Often the cultivator's best strategy

is *not* to seek the highest overall yield. The first, second, and third crops (or *flushes*) are usually the best, with each successive flush decreasing. For indoor cultivators, who are concerned with optimizing yield and crop rotation from each growing room, maximizing yield indoors may incur unacceptable risks. For instance, as the mycelium declines in vigor after several flushes, contaminants begin to flourish. Future runs are quickly imperiled.

If growing on sterilized sawdust, I recommend removing the blocks after the third flush to a specially constructed, four sided, open-air netted growing room. This over-flow or "yield-recapture" environment is simply fitted with an overhead nozzle misting system. Natural air currents provide plenty of circulation. These recapture buildings give bonus crops and require minimum maintenance. Growers in Georgia and Louisiana have perfect climates for this al-

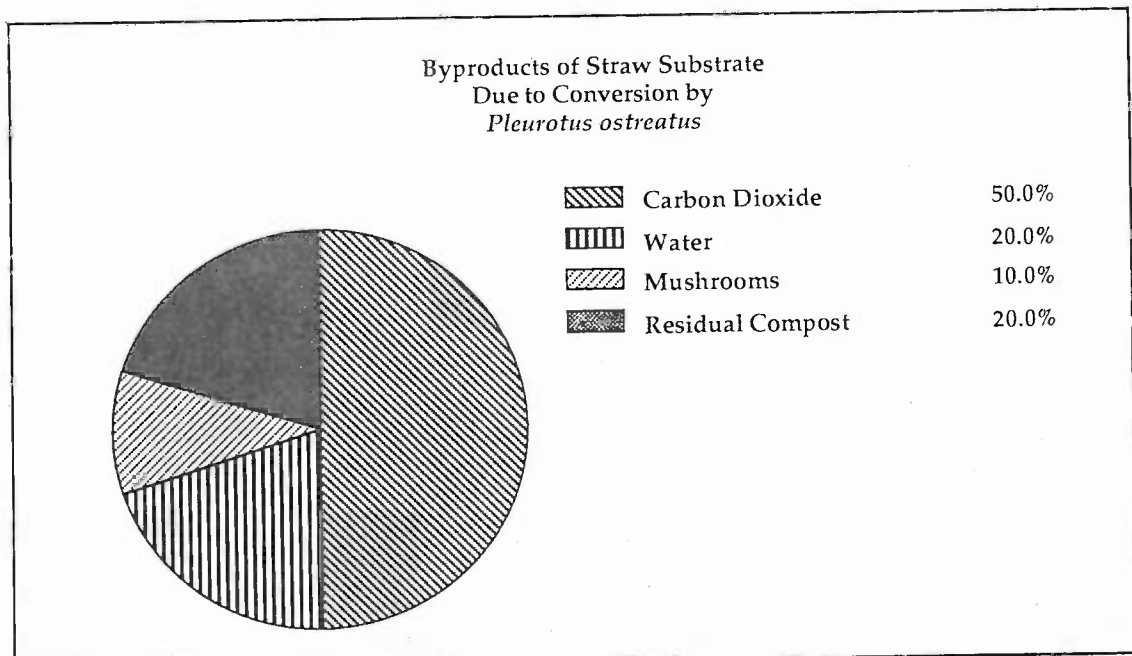

Figure 39. Chart showing comparison of by-products generated by Oyster (*Pleurotus ostreatus*) mycelium's decomposition of wheat straw. (Adapted from Zadrazil (1976)).

ternative. Subtropical regions of Asia are similarly well suited. (For more information, see Appendix I.)

Biological efficiency depends upon the stage of mushrooms at harvest. Young mushrooms ("buttons") are generally more selectible and store better. Yet if the entire crop is picked as buttons, a substantial loss in yield potential (B. E.) occurs. Mature mushrooms, on the other hand, may give the cultivator maximum biological efficiency, but also a crop with a very

short shelf life and limited marketability.

Each species passes through an ideal stage for harvesting as it matures. Just prior to maturity, features are transformed through the re-proportionment of cells without any substantial increase in the total weight of a mushroom as it matures. This is when the mushroom margins are decurved (pointing downwards) or slightly incurved, and well before spore generation peaks. Over time, cultivators learn the ideal stage for harvest.



Figure 40. Lillian Stamets holding bag of commercial *Agaricus brunnescens* spawn.

## Home-made vs. Commercial Spawn

**S**pawn is any form of mycelium that can be dispersed and mixed into a substrate. For most would-be cultivators, the easiest way to grow mushrooms is to buy spawn from a company and mix it (*inoculate*) into a substrate. Spawn can be purchased in a variety of forms. The most common forms are grain or sawdust spawn. Grain spawn is typically used by commercial cultivators to inoculate sterilized or pasteurized substrates. The White Button industry traditionally depends on highly specialized companies, often family-owned, which have made and sold spawn for generations.

Most amateurs prefer buying spawn because they believe it is easier than generating their own. This is not necessarily the case. Because spawn is a living organism, it exists precariously. Spawn remains in a healthy state for a very limited period of time. Usually after 2 months, even under refrigeration, a noticeable decline in viability occurs. After this “honeymoon” period, spawn simply over-matures

for lack of new food to digest. The acids, enzymes, and other waste products secreted by the mushroom mycelium become self-stifling. As the viability of the spawn declines, predator fungi and bacteria exploit the rapidly failing health of the mycelium. A mycelial malaise seizes the spawn, slowing its growth once sown onto new substrates and lowering yields. The most common diseases of spawn are competitor molds, bacteria, and viruses. Many of these diseases are only noticeable to experienced cultivators.

For the casual grower, buying commercial spawn is probably the best option. Customers of commercial spawn purveyors should demand: the date of inoculation; a guarantee of spawn purity; the success rate of other clients using the spawn; and the attrition rate due to shipping. Spawn shipped long distances often arrives in a state very different from its original condition. The result can be a customer-relations nightmare. I believe the wisest course is for commercial mushroom growers to generate their own spawn. The advantages of making your own spawn are:

1. *Quality control*: With the variable of shipping removed, spawn quality is better assured. The constant jostling breaks cells and wounds the spawn.

2. *Proprietary Strain Development*: Cultivators can develop their own proprietary strains. The strain is the most important key to success. All other factors pale in comparison.

3. *Reduction of an expense*: The cost of generating your own spawn is a mere fraction of the price of purchasing it. Rather than using a spawn rate of only 3-6% of the mass of the to-be-inoculated substrate, the cultivator can afford to use 10-12+ % spawning rates.

4. *Increasing the speed of colonization*. With higher spawning rates, the window of opportunity for contaminants is significantly narrowed and yields are enhanced. Using the spawn as the vehicle of supplementation is far better than trying to boost the nutritional base of the substrate prior to inoculation.

5. *Elimination of an excuse for failure*. When a production run goes awry, the favorite excuse is to blame the spawn producer, whether at fault or not. By generating your own spawn, you assume full responsibility. This forces owners to scrutinize the in-house procedures that led to crop failure. Thus, cultivators who generate their own spawn tend to climb the learning curve faster than those who do not.

6. *Insight into the mushroom life cycle*. Mycelium has natural limits for growth. If the spawn is "over-expanded", i. e. it has been transferred too many times, vitality falters. Spawn in this condition, although appearing healthy, grows slowly and often shows symptoms of genetic decline. A spawn producer making spawn for his own use is especially keen at using spawn at the peak of its vitality. These insights can not be had by those who buy spawn from afar.

---



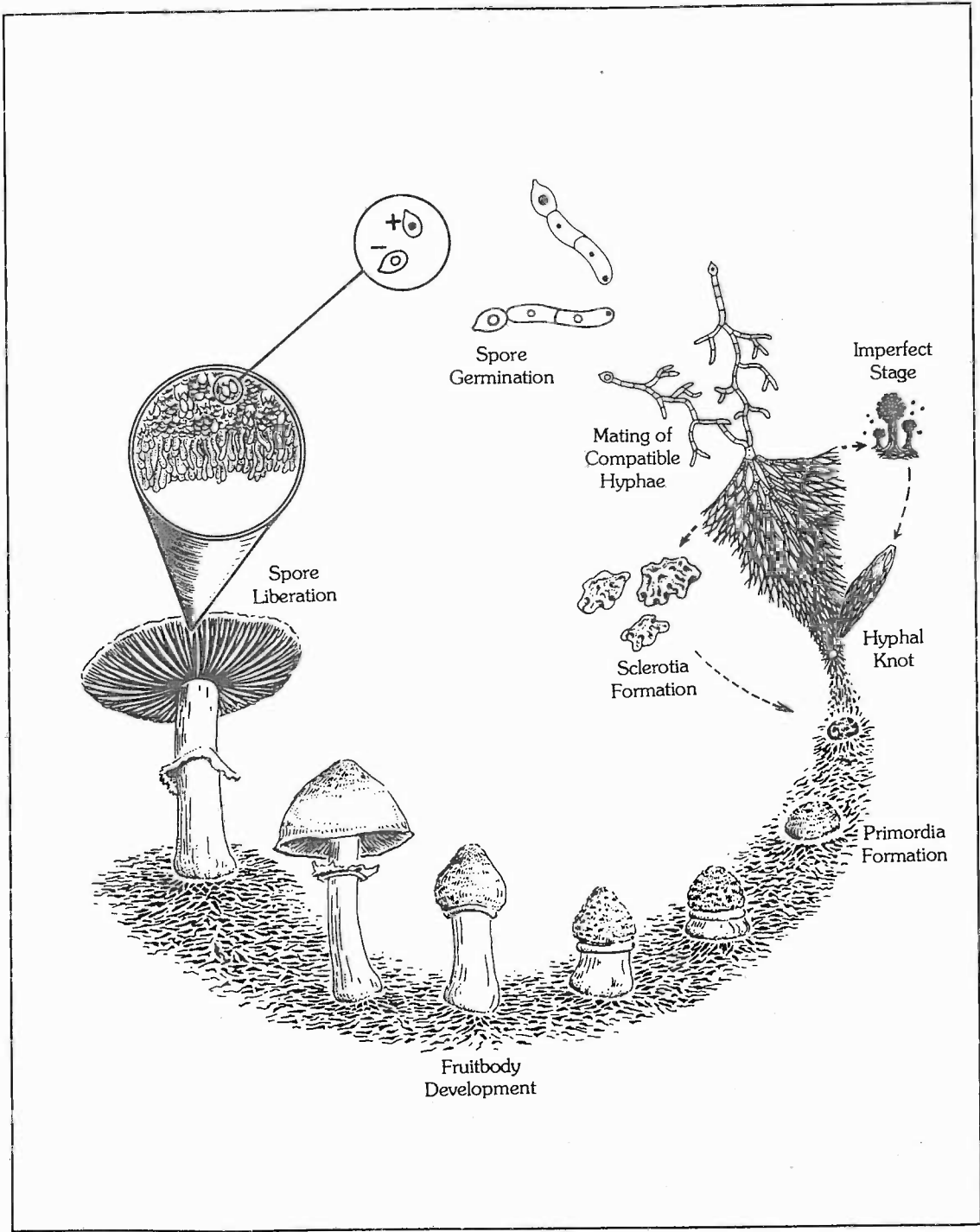

Figure 41. The Mushroom Life Cycle. Note that only a few species have a sclerotial and an imperfect stage.



# The Mushroom Life Cycle

**W**hen a collector finds mushrooms in the wild, the encounter is a mere coincidence, a “snap-shot” in time of a far vaster process. The mushroom life cycle remains largely invisible to most mushroom hunters; not so to cultivators. The mushroom cultivator follows the path of the mushroom life cycle from beginning to end. Only at the completion of the mushroom life cycle, which may span weeks or months, do mushrooms appear, and then they occur for but a few days. The stages leading up to their appearance remains fascinating even to the most sagacious mycologists.

For mushrooms to survive in our highly competitive world, where legions of other fungi and bacteria seek common ecological niches, millions of spores are often produced per mushroom. With the larger agarics, the numbers become astronomical. Since mushrooms reproduce through spores, the success of the mushroom life cycle depends upon their production.

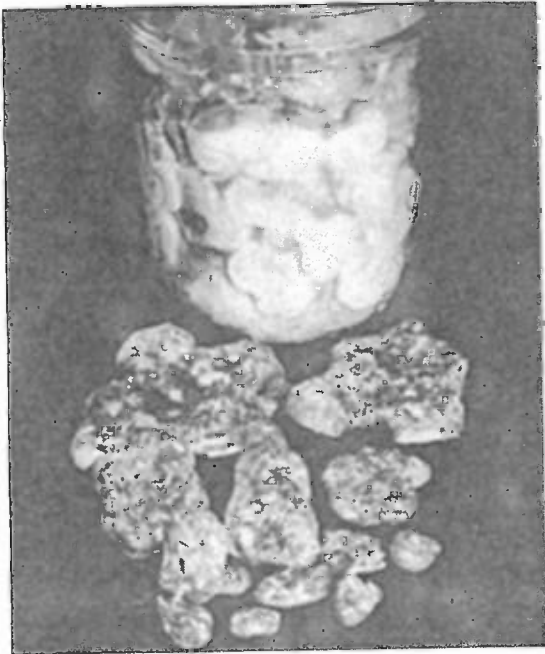

Figure 42. Sclerotia of *Psilocybe mexicana*.

Each spore that is released possesses one half of the genetic material necessary for the propagation of the species. Upon germination, a filamentous cell called a hypha extends. Hyphae continue to reproduce mitotically. Two hyphae, if compatible, come together, fuse, and combine genetic material. The resulting mycelium is then described as being *binucleate* and *dikaryotic*. After this union of genetic material, the dikaryotic mycelium accelerates in its growth, again reproducing mitotically. Mated mycelium characteristically grows faster than unmated mycelium arising from single spores.

The mating of compatible hyphae is genetically determined. Most of the gourmet species are governed by two incompatibility factors (A and B). As a result only subsets of spores are able to combine with one another. When spores germinate, several strains are produced. Incompatible strains grow away from each other,

establishing their own territorial domains. In this sense, spores from one mushroom can actually compete with one another for the same ecological niche.

Each mushroom is like an island. From this center, populations of spores decrease with distance. When spores germinate, the mycelium grows out radially, away from the site of origin. Often times, the next hospitable environment may be far away. Spores, taken up by the wind, or carried by insects and mammals, are dispersed to habitats well distant from the parent mushroom. By coincidence, different varieties of the same species meet and exchange genetic material. In the ever-changing ecological landscape, new varieties are favorably selected for and survive. This diversity within a species is critical to preserving its ability to adapt.

Enzymes and acids are secreted by the mushroom mycelium into the surrounding en-

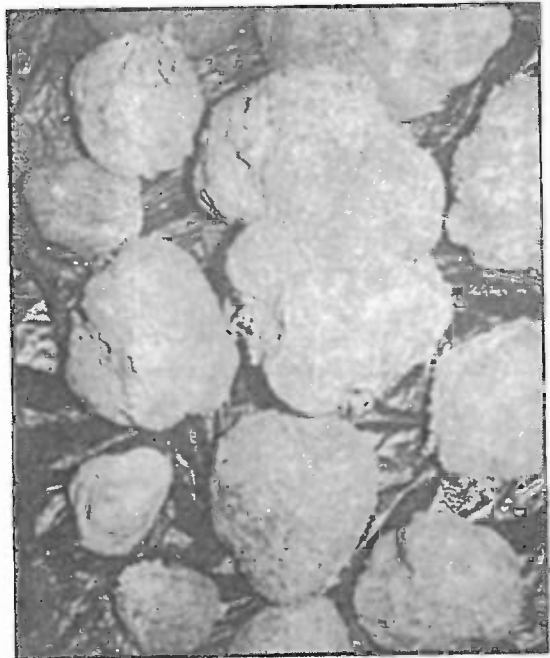

Figure 43. Sclerotia of *Pleurotus tuber-regium*.

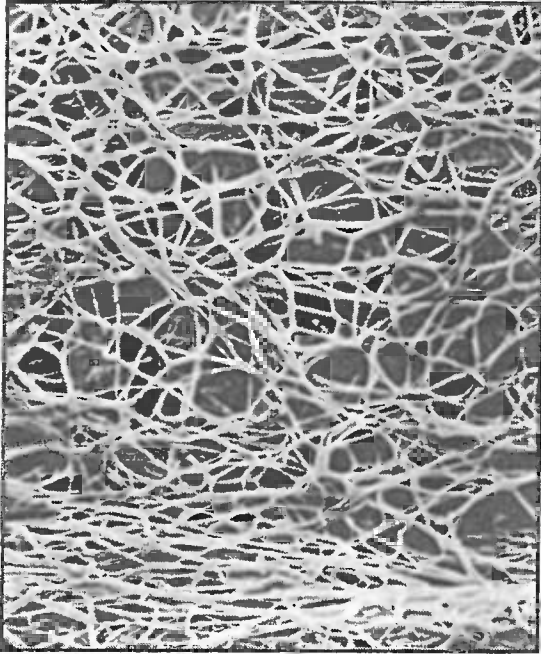

Figure 44. Scanning electron micrograph of mycelium.

vironment, breaking down lignin-cellulose complexes into simpler compounds. The mushroom mycelium absorbs these reduced organic molecules as nutrients directly through its cell walls. After one mushroom species has run its course, the partially decomposed substrate becomes available to secondary and tertiary saprophytes who reduce it further. Ultimately, a rich soil is created for the benefit of plants and other organisms.

As the mycelium expands, a web of cells is formed, collectively called the *mycelial network*. The arrangement of these cells is designed to optimally capture an ecological niche. Species differ in the manner by which the mycelial mat is projected. Initially, Morel mycelium throws a thinly articulated mycelial network. (Morel mycelium is the fastest-growing of any I have seen.) Once a substantial territorial domain has been over-run, side

branching of the mycelium occurs, resulting in a thickening of the mycelial mat.

With the approach of winter, the mycelial mat retreats to survive in specific sites. At this time, many mushrooms, both gilled and non-gilled, produce *sclerotia*. Sclerotia are a resting phase in the mushroom life cycle. Sclerotia resemble a hardened tuber, wood-like in texture. (See Figures 42 and 43.) While in this dormant state, the mushroom species can survive inclement weather conditions like drought, fire, flooding, or other natural catastrophes. In the spring, the sclerotia swell with water and soften. Directly from the sclerotia, mushrooms emerge. Morels are the best known mushrooms which arise from sclerotia. (See Figures 359-360). By the time you find a mature Morel, the sclerotia from which it came will have disappeared.

Most saprophytic mushrooms produce a thick mycelial mat after spore germination. These types of mycelial mats are characterized by many cross-overs between the hyphae. When two spores come together and mate, the downstream mycelium produces bridges between the cells, called *clamp connections*. Clamp connections are especially useful for cultivators who want to determine whether or not they have mated mycelium. Mycelium arising from a single spore lacks clamp connections entirely, and is incapable of producing fertile mushrooms.

As the mycelial network extends, several by-products are produced. Besides heat, carbon dioxide is being generated in enormous quantities. One study (Zadrazil, 1976) showed that nearly 50% of the carbon base in wheat straw is liberated as gaseous carbon dioxide in the course of its decomposition by Oyster mushrooms! 10% was converted into dried mushrooms; 20% was converted to proteins. Other by-products include a variety of volatile

alcohols, ethylenes, and other gases. (See Figure 39.)

While running through a substrate, the mycelium is growing vegetatively. The vegetative state represents the longest phase in the mushroom life cycle. The substrate will continue to be colonized until physical boundaries prevent further growth or a biological competitor is encountered. When vegetative colonization ceases, the mycelium enters into temporary stasis. Heat and carbon dioxide evolution decline, and nutrients are amassed within the storage vestibules of the cells. This resting period is usually short-lived before entering into the next phase.

From the natural decline in temperature within the host substrate, as well as in response to environmental stimuli (water and humidity, light, drop in temperature, reduction in carbon dioxide, etc. ), the mushroom mycelium is triggered into mushroom production. The

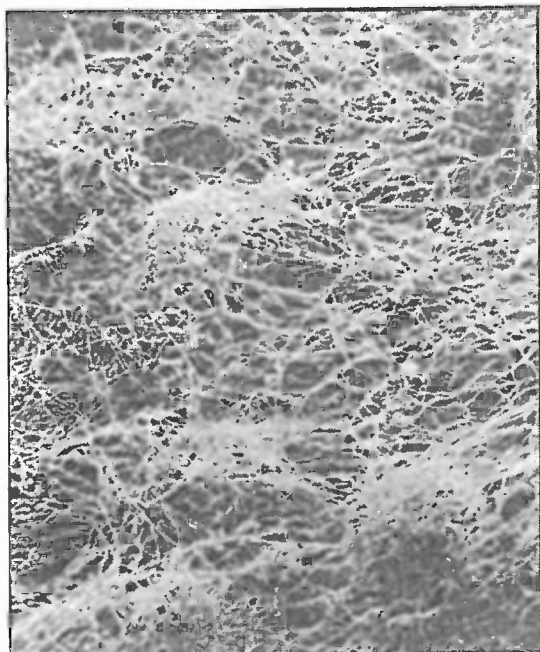

Figure 45. Primordia form and enlarge.

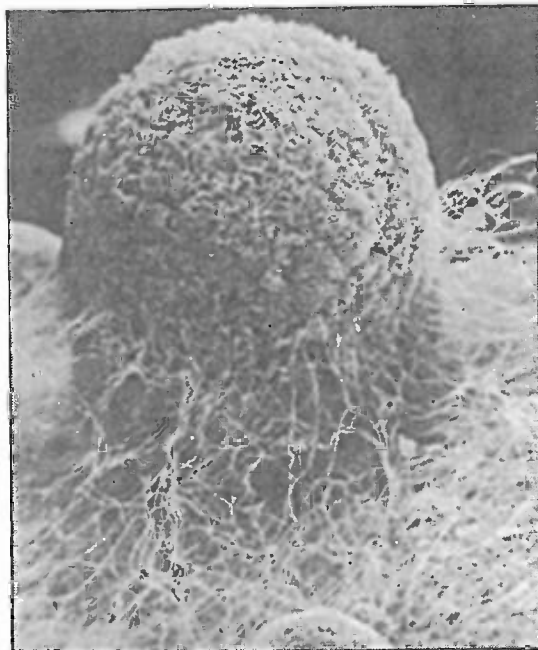

Figure 46. A miniature mushroom emerges from the mycelial plateau.

mechanism responsible for this sudden shift from active colonization to mushroom formation is unknown, often being referred to as a "biological switch." The mosaic of mycelium, until now homogeneously arranged, coalesces into increasingly dense clusters. (See Figure 45). Shortly thereafter—literally minutes with some species—these hyphal aggregates form into young primordia. (See Figure 46). In quick succession, the first discernible differentiation of the cap can be seen.

The period of primordia formation is one of the most critical phases in the mushroom cultivation process. Both mycelium and cultivator must operate as a highly coordinated team for maximum efficiency. Bear in mind that it is the mycelium that yields the crop; the cultivator is merely a custodian. The duration for primordia formation can be as short as 2 days or as long as 14. If managed properly, the microscopic land-

scape, the *mycosphere*, will give rise to an even, high-density population of rapidly forming primordia. Visible to the naked eye, the mycelium's surface is punctuated with a lattice-work of valleys and ridges upon which moisture droplets continually form, rest, and evaporate. In the growing room this period corresponds to 98-100 % rH, or a condensing fog. Even in a fog, air currents have an evaporative effect, drawing moisture to the surface layer. The careful management of this mycosphere, with high oxygen, wicking, evaporation, and moisture replenishment combined with the effect of other environmental stimuli results in a crescendo of primordia formation. Cultivators call these environmental stimuli, collectively, the *initiation strategy*.

Primordia, once formed, may rest for weeks, depending upon the species and the prevailing environment. In most cases, the primordia ma-

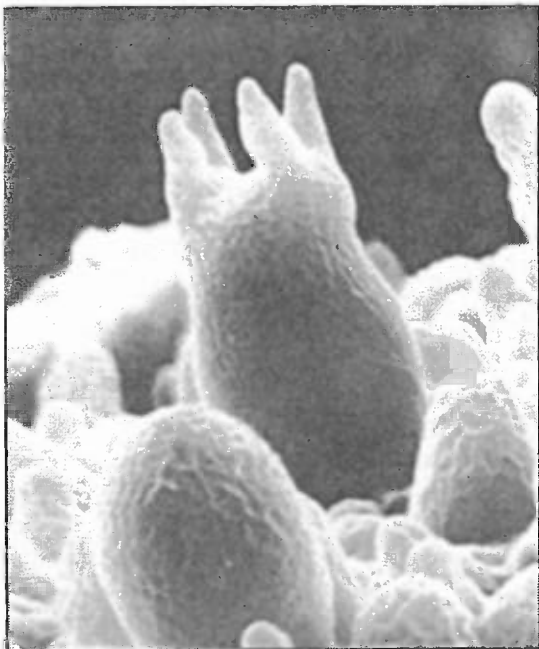

Figure 47. As the basidia mature, sterigmata project from the apices.

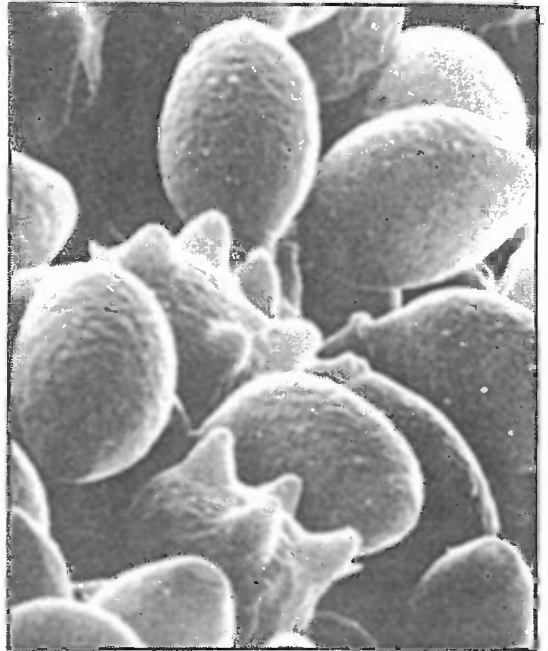

Figure 48. Scanning electron micrograph of young basidium.

ture rapidly. Rhizomorphs, braided strands of large diameter hyphae, feed the burgeoning primordia through cytoplasmic streaming. The cells become multinucleate, accumulating genetic material. Walls or *septae* form, separating pairs of nuclei, and the cells expand, resulting in an explosive generation of mushroom tissue.

As the mushroom enlarges, differentiation of familiar features occurs. The cap, stem, veil, and gills emerge. The cap functions much like an umbrella, safeguarding the spore-producing gills from wind and rain. Many mushrooms grow towards light. A study by Badham (1985) showed that, with some mushroom species (i. e. *Psilocybe cubensis*), cap orientation is foremost affected by the direction of air currents, then by light, and finally by gravity. Beneath the cap, the gill plates radiate outwards from a centralized stem like spokes on a wheel.

Over the surface of the gills, an evenly dis-

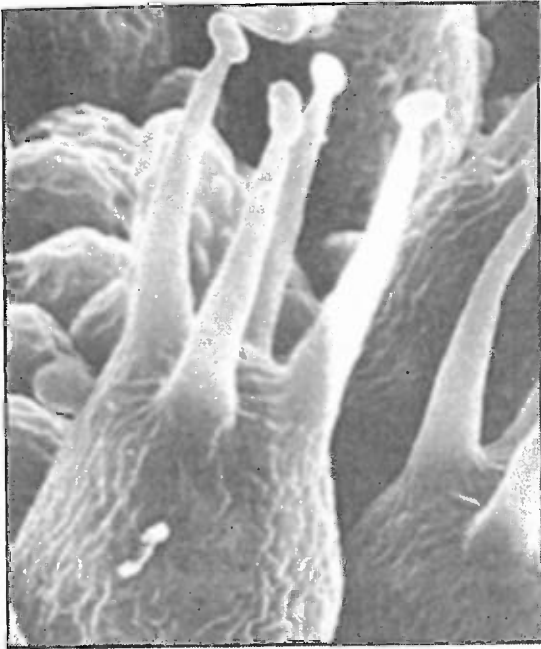

Figure 49. At each tip of the sterigmata, a spore forms.

persed population of spore-producing cells called *basidia* emerge. The basidia arise from a genetically rich, dense surface layer on the gill called the *hymenium*. The gill trama is nestled between the two hymenial layers and is composed of larger interwoven cells, which act as channels for feeding the hymenial layers with nutrients. (See Figure 53). When the mushrooms are young, few basidia have matured to the stage of spore release. As the mushrooms emerge, increasingly more and more basidia mature. The basidia are club-shaped, typically with four “arms” forming at their apices. These arms, the *sterigmata*, project upwards, elongating. (See Figures 47 and 48). In time, each tip swells to form small a globular cavity which eventually becomes a spore. (Figure 49).

Initially, the young basidia contain two haploid, sexually paired nuclei. They fuse, in a process known as *karyogamy*, to form one diploid nucleus containing a full complement of

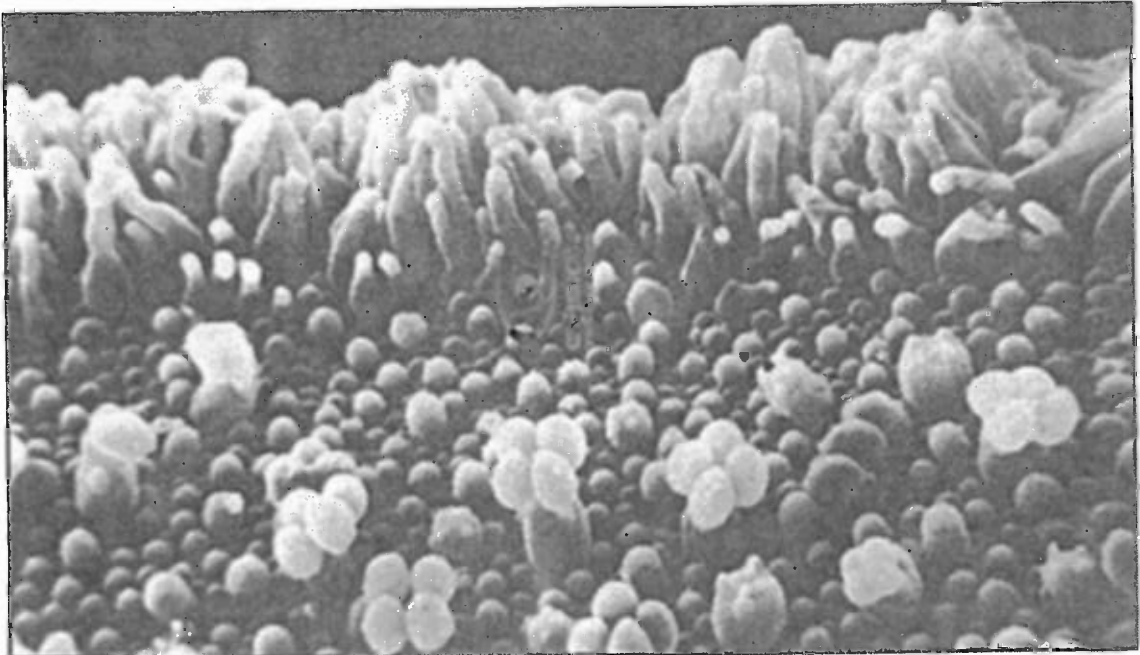

Figure 50. Populations of basidia evenly emerge from the gill plane.

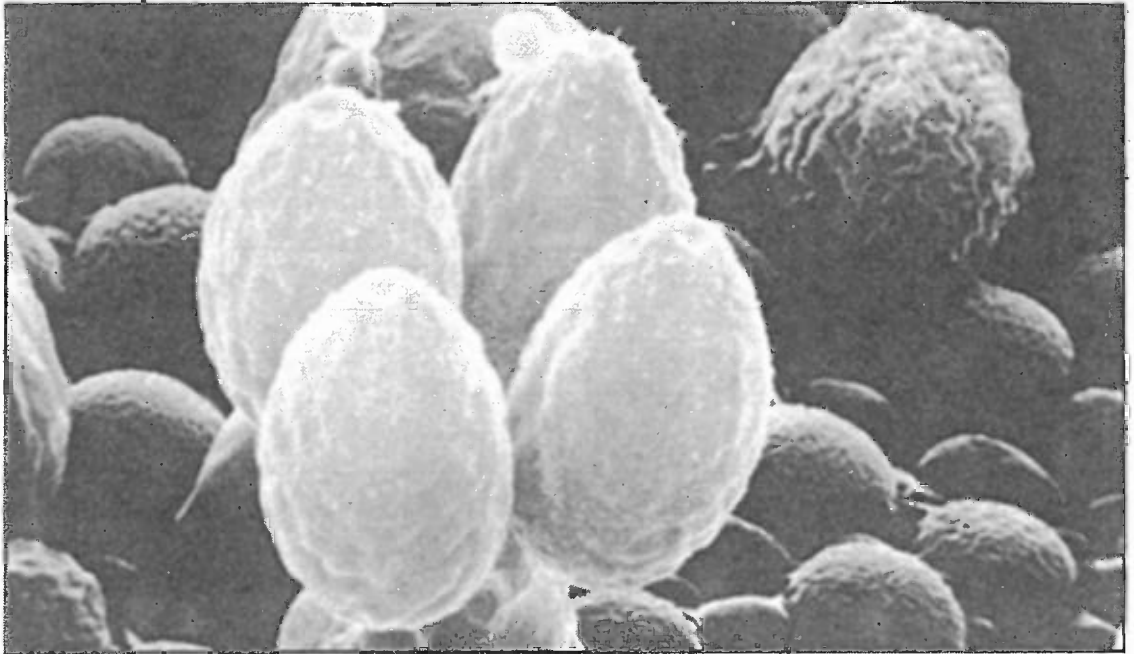

Figure 51. A fully mature basidium. Note germ pores at open ends of spores.

chromosomes. Immediately thereafter, meiosis or reduction division occurs, resulting in four haploid nuclei. The haploid nuclei are elastic in form, squeezing up the sterigmata to be deposited in their continually swelling tips. Once residing in the newly forming spore cavity, the spore casing enlarges. Each spore is attached to the end of each sterigma by a nipple-like protuberance, called the *sterigmal appendage*. With many species, the opposite end of the spore is dimpled with a *germ pore*. (See Figure 51).

The four spores of the basidia emerge diametrically opposite one another. This arrangement assures that the highly viscous spores do not touch. Should a young spore come into contact with another before their outer shells harden, they fuse and development is arrested. The spores become pigmented at maturity and are released in sets of paired op-

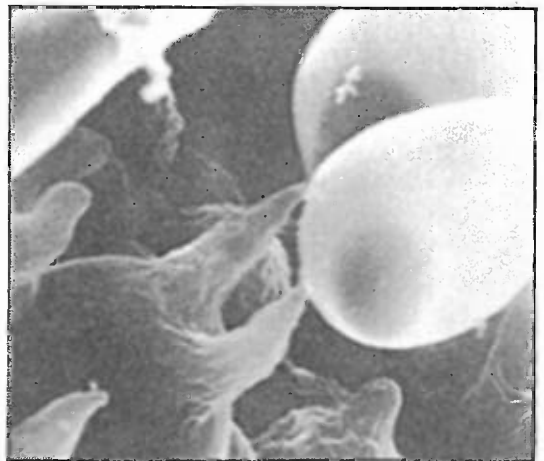

Figure 52. Two spored basidium. Comparatively few mushrooms have two spored basidia; most are four spored.



Figure 53. Scanning electron micrograph showing cross-section of gill.

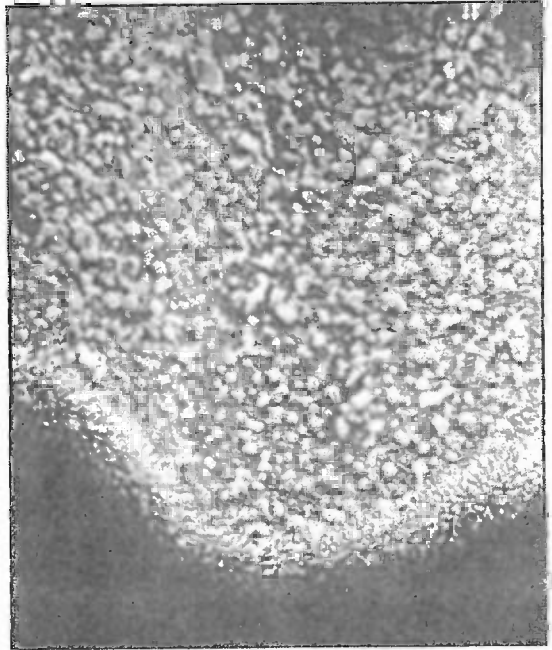

Figure 54. A band of Cheilocystidia on edge of gill.

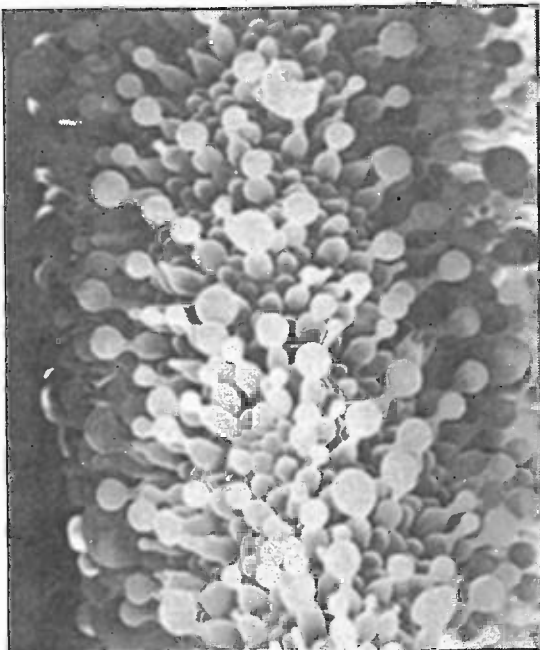

Figure 55. Close-up of cheilocystidia

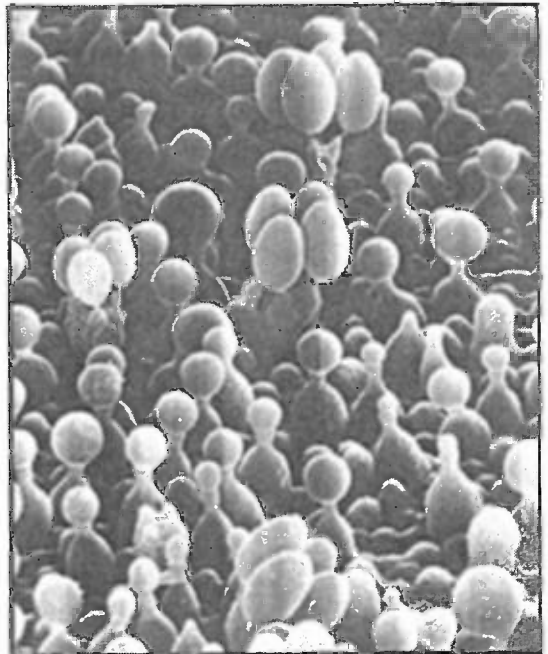

Figure 56. Pleurocystidia and basidia on surface of gill.



posites.

The method of spore ejection has been a subject of much study and yet still remains largely a mystery. At the junction between the spore and the basidium's sterigma, an oily gas bubble forms and inflates. This bubble swells to capacity and explodes, ejecting spores with a force that has been calculated to represent more than 6 atmospheres of pressure! After ejaculation, the basidium collapses, making way for neighboring basidia, until now dormant, to enlarge. Successions of basidia mature, in ever increasing quantities, until peaking at the time of mushroom maturity. The well organized manner by which populations of basidia emerge from the plane of the gill optimizes the efficiency of spore dispersal. After peak spore production, spores cover the gill face several layers deep, hiding the very cells from which they arose. With a *Stropharia*, this stage would correspond to a mushroom whose gills had become dark purple brown and whose cap had flattened. Spore release at this stage actually declines as the battery of basidia has been largely exhausted and/or because the basidia are rendered dysfunctional by the sea of overlying spores.

Sterile or non-spore-producing cells that adorn the gills are called *cystidia*. Cystidia on the edge of the gills are called *cheilocystidia*, while cystidia on the interior surface are called *pleurocystidia*. (See Figures 54, 55 and 56). The cystidia appear to help the basidia in their development. The extensive surface areas of the cheilocystidia cause the humidity between the gills to rise, thus preserving the hospitable moist microclimate necessary for spore maturity. Some pleurocystidia can project well beyond the surface plane of basidia, and in doing, keep the gills from contacting one another. Should the gills touch, spore dispersal is greatly hampered. As the

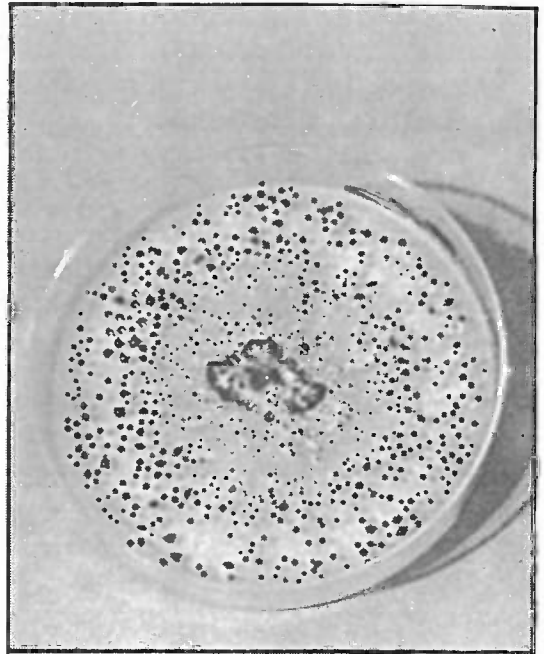

Figure 57. Mycelium of *Pleurotus cystidiosus* and allies, species possessing both sexual and asexual life cycles. Black droplet structures contain hundreds of spores.

mushrooms mature, cystidia swell with metabolic waste products. Often times an oily droplet forms at their tips. The constant evaporation from these large reservoirs of metabolites is an effective way of purging waste by-products and elevating humidity. Some species having pleurocystidia often have a high number of gills per mm. of radial arc. In other words: more gills; more spores. The survival of the species is better assured.

Once spores have been discharged, the life cycle has come full circle. Mature mushrooms become a feasting site for small mammals (rodents such as squirrels, mice, etc. ), large mammals (deer, elk, bears, humans), insects, gastropods (snails), bacteria, and other fungi. From this onslaught, the mushroom quickly decomposes. In due course, spores not

transmitted into the air are carried to new ecological niches via these predators.

Many mushrooms have alternative, asexual life cycles. Asexual spores are produced much in the same manner as mold spores—on microscopic, tree-like structures called conidiophores. Or, spores can form imbedded within the mycelial network. Oidia, chlamydospores, and coremia are some examples of asexual reproduction. In culture, these forms appear as “contaminants,” confusing many cultivators. An excellent example is the Abalone Mushroom, *Pleurotus cystidiosus* and allies. (See Figure 57). The advantage of asexual reproduction is that it is not as biologically taxing as mushroom formation. Asexual reproduction disperses spores

under a broader range of conditions than the rather stringent parameters required for mushroom formation. In essence, asexual expressions represent short-cuts in the mushroom life cycle.

A cultivator’s role is to assist the mycelium as it progresses through the life cycle by favorably controlling a multitude of variables. The cultivator seeks maximum mushroom production; the mycelium’s goal is the release of the maximum number of spores through the formation of mushrooms. Both join in a biological partnership. But first, a strain from the wild must be captured. To do so, the cultivator must become skilled at sterile technique. And to be successful at sterile technique requires a basic understanding of the Vectors of Contamination.

## The Six Vectors of Contamination

Cultivating mushroom mycelium in a laboratory is tantamount to not cultivating contaminants. Diagnosing the *source* of contamination, and the *vector* or pathway through which contaminants travel is the key to tissue culture. Over the years, I have identified 6 distinct and separate vectors of contamination. If a contaminant arises in the laboratory, the cultivator should examine each vector category as being the possible cause of the problem. Through a process of elimination, the distressed cultivator can determine the vector through which the contaminants are spread. Once discovered, the vector can be closed, and the threat eliminated. If one vector is open, then a multitude of contaminants pass through it, often times confounding the diagnoses of inexperienced cultivators.

The principal vectors of contamination are:

1. **The Cultivator**
2. **The Air**
3. **The Media**
4. **The Tools**
5. **The Inoculum**
6. **Mobile Contamination Units (MCU's)**

The over-riding coefficients affecting each vector are *the number of contaminants* and *the exposure time*. The more of each, the worse the infestation. This book does not go into detail as to the identity of the common contaminants. However, my previous book, *The Mushroom Cultivator* (1983), co-authored with Jeff Chilton, has extensive chapters on the identity of the molds, bacteria, and insects. The reader is encouraged to refer to that manual for the identification of contaminants. All contaminants are preventable by eliminating the Six Vectors of Contamination. If you have difficulty determining the vector of contamination, or a solution to a problem, please refer to Chapter 25: Cultivation Problems and Their Solutions: A Trouble-Shooting Guide.

**1. You, The Cultivator:** The human body teems with populations of micro-organisms. Diverse species of fungi (including yeast), bacteria and viruses call your body their home. When you are healthy, the populations of these microorganisms achieve an equilibrium. When you are ill, one or more of these groups proliferate out of control. Hence, unhealthy people should not be in a sterile laboratory, lest their disease organisms escape and proliferate to dangerous proportions.

Most frequently, contaminants are spread into the sterile laboratory via touch or breath. Also, the flaking of the skin is a direct cause. Many cultivators wear gloves to minimize the

threat of skin-borne contaminants. I, personally, find laboratory gloves uncomfortable and prefer to wash my hands every 20 or 30 minutes with antibacterial soap. Additionally my hands are disinfected with 80% isopropyl alcohol immediately before inoculations, and every few minutes throughout the procedure.

**2. The Air:** Air can be described as a sea of microorganisms, hosting invisible contaminants that directly contaminate sterilized media once exposed. Many particulates remain suspended. When a person walks into the laboratory, he not only brings in contaminants that will become airborne, but his movement disturbs the contaminant-laden floor, re-releasing contaminants into the lab's atmosphere.

Several steps can prevent this vector of contamination. One rule-of-thumb is to always have at least three doors prior to entry into the sterile laboratory from the outside. Each room or chamber shall, by default, have fewer airborne particulates the nearer they are to the laboratory. Secondly, by positive-pressurizing the laboratory with an influx of air through micron filters, the airstream will naturally be directed against the entering personnel. (For the design of the air system for a laboratory, see Appendix I).

For those not installing micron filters, several alternative remedies can be employed. Unfortunately, none of these satisfactorily compare with the efficiency of micron filters. "Still-air" laboratories make use of aerosol sprays—either commercial disinfectants like Pinesol® or a dilute solution of isopropanol or bleach. The cultivator enters the work area and sprays a mist high up in the laboratory, walking backwards as he retreats. As the disinfecting mist descends, airborne particulates are trapped, carrying the contaminants to the

---

floor. After a minute or two, the cultivator, re-enters the lab and begins his routine. (Note that you should not mix disinfectants—especially bleach and ammonia. Furthermore, this method can potentially damage your lungs or exposed mucous membranes. Appropriate precautions are strongly recommended.)

Without the exchange of fresh air, carbon dioxide levels will naturally rise from out-gassing by the mushroom mycelium. As carbon dioxide levels elevate, contaminants are triggered into growth. An additional problem with heavily packed spawn rooms is that with the rise of carbon dioxide, oxygen levels proportionately decrease, eventually asphyxiating the laboratory personnel. Unless the air is exchanged, the lab becomes stifling and contamination-prone. Since the only way to exchange air without introducing contaminants is by filtering, the combination of fans and micron filters is the only recourse.

Other cultivators use ultraviolet lights which interfere with the DNA replication of all living organisms. UV lamps are effective when the contaminants are directly exposed. However, since shadowed areas are fully protected from UV exposure, contaminants in those regions remain unaffected. I disdain the use of UV in favor of the micron filter alternative. However, many others prefer their use. Note that the lab door should be electrically switched to the UV light so that the lamp turns off at entry. Obviously, exposure to UV light is health-threatening to humans, potentiating skin cancer and damage to the cornea of the eye.

Frequently, the vector of airborne contamination is easy to detect because of the way it forms on petri dishes. Airborne contaminants enter a petri dish either at the time the lid is opened (during pouring or inoculation) or dur-

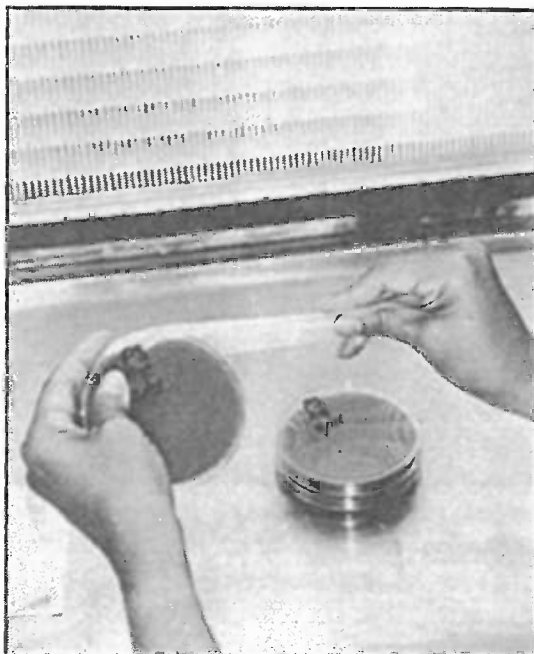

**Figure 58.** Using an elastic film to seal the top and bottom of petri dishes. This eliminates the chance of airborne contamination entering during incubation.

ing incubation. When the dish is opened, airborne contamination can spread evenly across the face of nutrient media. During incubation, contaminants creep in and form along the inside periphery of the petri dish. This latter occurrence is most common with laboratories with marginal cleanliness. A simple solution is to tape together the top and bottom of the petri dish directly after pouring and/or inoculation using elastic wax film. (Parafilm® is one brand. See Figure 58.) Plastic, stretchable kitchen wraps available in most grocery stores also can be used. These films prevent entry of contaminant spores that can occur from the fluctuation of barometric pressure due to natural changes in weather patterns.

One helpful tool in eliminating each vector of contamination as the source is to leave con-

tainers of media uninoculated. For instance, the cultivator should always leave some culture dishes uninoculated and unopened. These "blanks" as I like to call them, give the cultivator valuable insights as to which vector of contamination is operating. *At every step in the cultivation process, "blanks" should be used as controls.*

The air in the growing rooms does not require the degree of filtration needed for the laboratory. For mushroom cultivators, cleaning the air by water misting is practical and effective. (Rain is nature's best method of cleansing the air.) This cultivator's regimen calls for the spraying down of each growing room twice a day. Starting from the ceiling and broadcasting a spray of water back and forth, the floor is eventually washed towards the center gutter. The room *feels* clean after each session. Each wash-down of a 1000 sq. ft. growing room takes about 15 minutes. This regimen is a significant factor in maintaining the quality of the growing room environment.

**3. The Media:** Often the medium upon which a culture is grown becomes the source of contamination. Insufficient sterilization is usually the cause. Standard sterilization time for most liquid media is only 15-20 minutes at 15 psi or 250° F. (121° C.). However, this exposure time is far too brief for many of the endospore-forming bacteria prevalent in the additives currently employed by cultivators. I recommend at least 40 minutes @ 15 psi for malt extract or potato dextrose agars. If creating soil extracts, the soil must be soaked for at least 24 hours, and then the extracted water be subjected to a minimum of 1 hour of sterilization. Indeed, soil extracts are resplendent with enormous numbers of contaminants. Because of the large initial populations, do not be surprised if some contaminants survive this prolonged sterilization period. Should they

persist, then sterilizing the extracted water first, and then re-sterilizing it with standard malt sugar additives is recommended. Clearly, sterilization is best achieved when the media has a naturally low contamination content. (See Preparation of Media in Chapter 12.)

A good practice for all laboratory managers is to leave a few samples from each sterilization cycle uninoculated. *Not inoculating a few petri dishes, grain jars, and sawdust/bran bags and observing them for a period of two weeks can provide valuable information about the vectors of contamination.* These quality control tests can easily determine whether or not the media is at fault or there has been a failure in the inoculation process. Under ideal conditions, the uninoculated units should remain contamination-free. If they contaminate within 48-72 hours, this is usually an indication that the media or containers were insufficiently sterilized. If the containers are not hermetically sealed, and contaminants occur near to the end of two weeks, then the contamination is probably endemic to the laboratory, particularly where these units are being stored. Under ideal conditions, in a perfect universe, no contamination should occur no matter how long the uninoculated media is stored.

Many researchers have reported that sawdust needs only to be sterilized for two hours at 15 psi to achieve sterilization. (See Royse et al. (1990), Stamets and Chilton (1983)). However, this treatment schedule works only for small batches. When loading an autoclave with hundreds of tightly packed bags of supplemented sawdust, sterilization for this short a period will certainly lead to failure.

In the heat treatment of bulk substrates, absolute sterilization is impractical. Here, sterilization is more conceptual than achievable.

---

The best one can hope is that contaminants in the sawdust have been reduced to a level as to not be a problem, i. e. within the normal time frame needed for the mushroom mycelium to achieve thorough colonization. Again, the time period needed is approximately two weeks. *Should colonization not be complete in two weeks, the development of contaminants elsewhere in the substrate is not unusual.* Of course, by increasing the spawn rate, colonization is accelerated, and the window of opportunity favors the mushroom mycelium. The recommended sterilization times for various media are described in Chapters 15–17. Badham (1988) found that sterilization of supplemented sawdust under pressure for 4 hours at 19 psi was functionally similar (in terms of contamination reduction, growth rate, and yield of Shiitake) to high temperature pasteurization (190-194° F. or 88-90° C.) for 14 hours at atmospheric pressure (1 psi). Remote sensing thermometers, placed at a variety of depths, are used to determine a temperature profile. When the coolest probe reads 190° F. (88° C.), steam is continuously supplied for a minimum of 12 hours, preferably 14-16 hours depending on substrate mass.

Since heat penetration varies with each substrate material's density, and is co-dependent on the moisture content, the use of sterilization indicator strips is recommended to confirm that sterilization has actually occurred.

Yet another limiting factor is that media biochemically changes, potentially generating toxins to mycelial growth. Should malt agar be cooked for 2-3 hours at 18 psi, the resulting media changes into a clear, amber liquid as sugars have been reduced. Under these conditions, cultivators say the media has "caramelized" and generally discard the media and make up a new batch. Contaminants won't

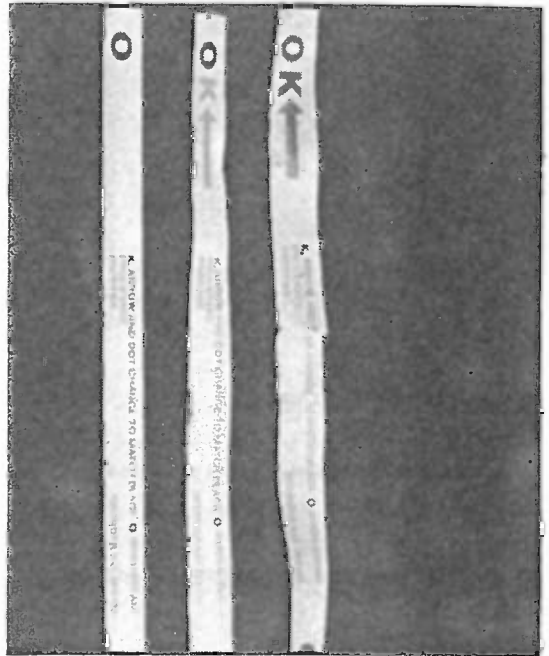

Figure 59. Heat-sensitive sterilization indicator strips showing no sterilization, partial sterilization, and complete sterilization.

grow on this media; nor does most mushroom mycelia. The cultivator is constantly faced with such dilemmas. What makes a good cultivator is one who seeks the compromises which lead most quickly to colonization and fruitbody production.

**4. The Tools:** In this category, all tools of the trade are included from the scalpel to the pressure cooker to the media vessels. Insufficient sterilization of the tools can be a direct vector since contact with the media is immediate. Flame-sterilizing scalpels is the preferred method over topical disinfection with alcohol or bleach. However, the latter is used widely by the plant tissue culture industry with few problems.

If you are using a pressure cooker for sterilizing media and other tools, many forget that although the interior of the vessel has been

sterilized, for all practical purposes, the outside of the vessel has not been. Contaminants can be easily picked up by the hands of the person handling the pressure cooker and re-distributed to the immediate workstation. All the more the reason one should disinfect before beginning transfers.

**5. The Inoculum:** The inoculum is the tissue that is being transferred, whether this tissue is a part of a living mushroom, mycelium from another petri dish, or spores. Bacteria and molds can infect the mushroom tissue and be carried with it every time a transfer is made. Isolation of the inoculum from the mushroom mycelium can be frustrating, for many of these contaminant organisms grow faster than the newly emerging mushroom mycelium. Cultivators must constantly "run" or transfer their mycelium away from these rapidly developing competitors. Several techniques can purify contaminated mycelium.

**6. MCU's, Mobile Contamination Units:** Mobile Contamination Units are organisms that carry and spread contaminants within the laboratory. These living macro-organisms act as vehicles spreading contaminants from one site to another. They are especially damaging to the laboratory environment as they are difficult to isolate. Ants, flies, mites, and in this author's case, small bipedal offspring (i. e. children) all qualify as potential MCU's. Typically, a MCU carries not one contaminant, but several.

Mites are the most difficult of these MCU's to control. Their minute size, their preference for fungi (both molds and mushroom mycelium) as food, and their penchant for travel, make them a spawn manager's worst nightmare come true. Once mite contamination levels exceed 10%, the demise of the labora-

tory is only one generation away. The only solution, after the fact, is to totally shut down the laboratory. All cultures must be removed, including petri dishes, spawn jars, etc. The laboratory should then be thoroughly cleansed several times. I use a 10% household bleach solution. The floors, walls, and ceiling are washed. Two buckets of bleach solution are used—the first being the primary reservoir, the second for rinsing out the debris collected in the first wipe-down. The lab is locked tight for each day after wash-down. By thoroughly cleansing the lab three times in succession, the problem of mites can be eliminated or subdued to manageable levels. Mycelia are regenerated from carefully selected stock cultures.

I have discovered "decontamination mats", those that labs use at door entrances to remove debris from footwear, are ideal for preventing cross-contamination from mites and similarly pernicious MCU's. Stacks of petri dishes are placed on newly exposed sticky mats on a laboratory shelf with several inches of space separating them. These zones of isolation, with culture dishes incubating upon the highly adhesive surface, make the migration of mites and other insects a most difficult endeavor. The upper sheet is removed every few weeks to expose a fresh, clean storage plane for new cultures.

All of these vectors are universally affected by one other variable: *Time of Exposure*. The longer the exposure of any of the aforementioned vectors of contamination, the more significant their impact. Good laboratory technicians are characterized not only by their speed and care, but by their rhythm. Transfers are done in a systematically repetitive fashion. Controlling the time of exposure can have a drastic impact on the quality of laboratory technique.

---



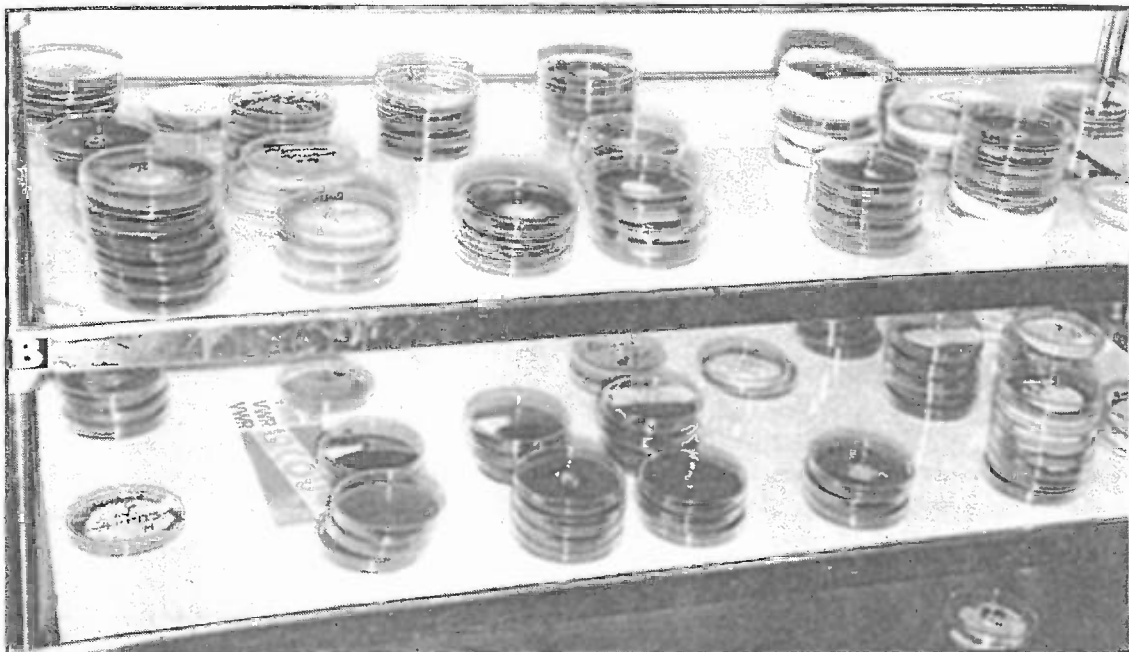

Figure 60. Storing petri dish cultures on “sticky mats” limits cross-contamination from mites and other mobile creatures.

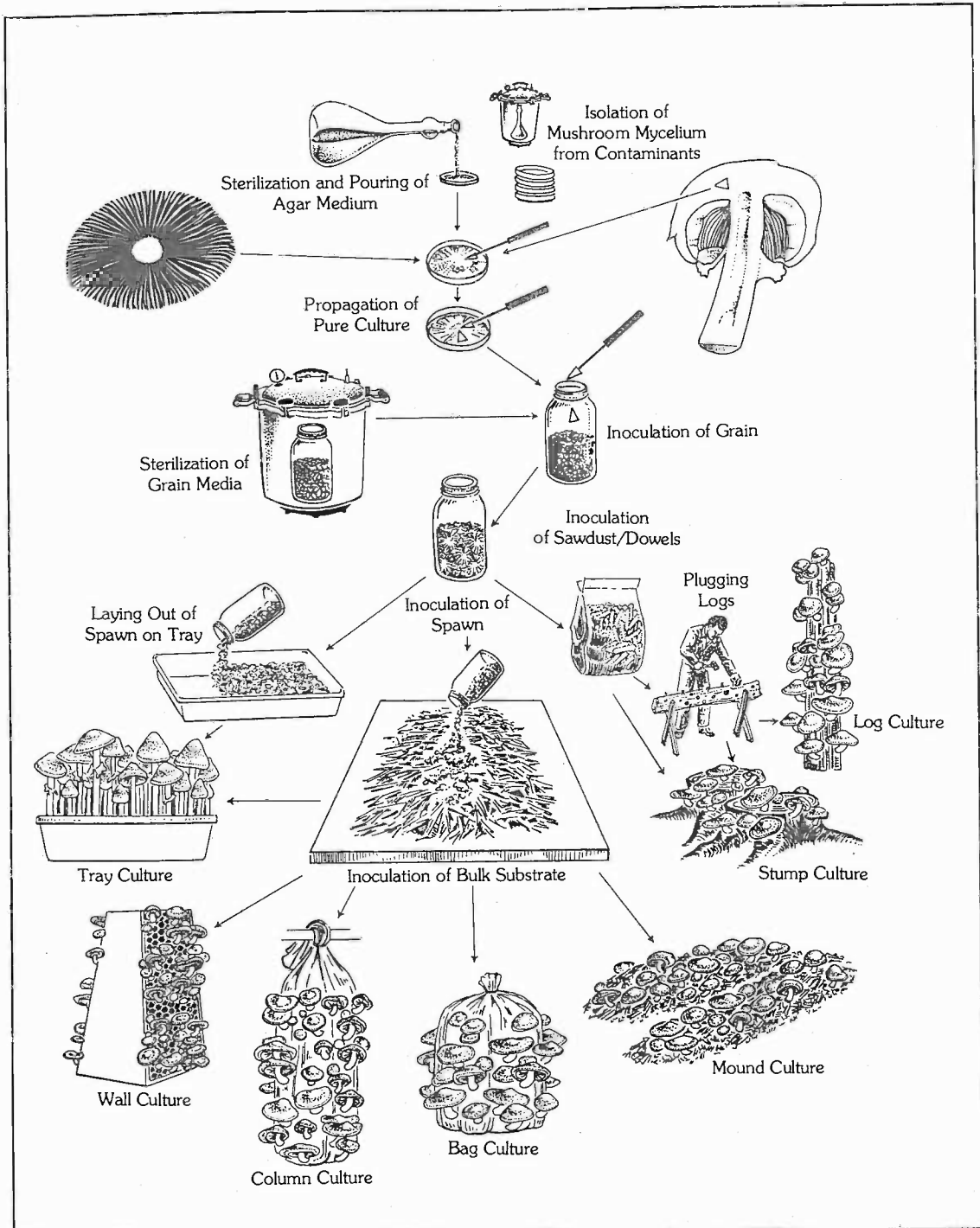

Figure 61. Overview of Techniques for Growing Mushrooms.

## Mind and Methods for Mushroom Culture

**S**terile tissue culture has revolutionized the biological sciences. For the first time in the history of human evolution, select organisms can be isolated from nature, propagated under sterile conditions in the laboratory, and released back into the environment. Since a competitor-free environment does not exist naturally on this planet\*, an artificial setting is created—the laboratory—in which select organisms can be grown in mass.

Louis Pasteur (1822-1895) pioneered sterile technique by recognizing that microorganisms are killed by heat, most effectively by steam or boiling water. Tissue culture of one organism—in absence of competitors—became possible for the first time. By the early 1900's growing organisms in pure culture became commonplace. Concurrently, several researchers discovered that mushroom mycelium could be grown under sterile conditions. However, the methods were not always successful. Without benefit of basic equipment, efforts were confounded by high levels of contamination and only after considerable effort was success seen. Nevertheless, methods slowly evolved through trial and error.

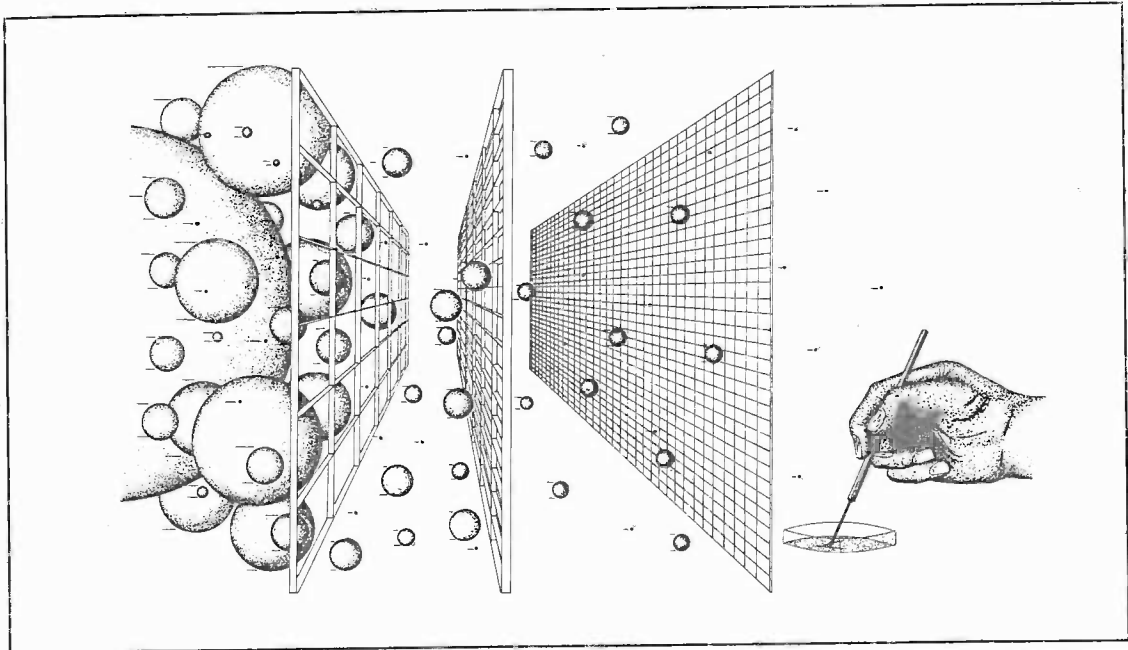

Figure 62. Diagrammatic representation of the effectiveness of filtration media. Dirty air is first filtered through a coarse prefilter (30% @  $10\ \mu$ ), then an electrostatic filters (99% @  $1\ \mu$ ), and finally through a High Efficiency Particulate Air (HEPA) filter (99.99% @  $.3\ \mu$ ). Only some free-flying endospores of bacteria and viruses pass through.

The monumental task of creating a sterile environment has been difficult, until recently. The invention of high efficiency particulate air filters (called HEPA filters) has made sterile tissue culture achievable to all. *In vitro* ("within glass") propagation of plants, animals, fungi,

bacteria, protozoa became commercially possible. Today, the HEPA (High Efficiency Particulate Air) filter is by far the best filtration system in use, advancing the field of tissue culture more-so than any other invention. \*\* When air is forcibly pressed through these filters, all contaminants down to  $.3\ \mu$  are eliminated with a 99.99% efficiency. This means only 1 of every 10,000 particulates exceeding  $.3\ \mu$  pass through. For all practical purposes, a sterile wind is generated downstream from the filter. The cultivator works within this airstream. This unique environment calls for unique techniques. A different set of rules now presides, the violation of which invites disaster.

Sterile tissue culture technique fails if it solely relies on mechanical means. Sterile tis-

\* Scientists have recently discovered a group of heat resistant bacteria thriving in the fumaroles of submerged, active volcanoes. These bacteria thrive where no other life forms live.

\*\* Many types of filtration systems are available. Ionizers, for our purposes, are insufficient in their air cleaning capacity. For a comparison of filtration systems, which rates HEPA filtration as the best, please refer to Consumer Reports, Oct. 1992, pg. 657. A new generation of micron filters, the ULPA filters screen out particulates down to  $.1\ \mu$  with a 99.9999% efficiency. This means only 1 particle measuring  $.1\ \mu$  in diameter of every 1,000,000 flows through the filtration medium.

sue culture technique is also a philosophy of behavior, ever-adjusting to ever-changing circumstances. Much like a martial art, the cultivator develops keen senses to constantly evaluate threats to the integrity of the sterile laboratory. These enemies to sterile culture are largely invisible and are embodied within the term “contaminant”.

A contaminant is anything you don’t want to grow. Classically, *Penicillium* molds are contaminants to mushroom culture. However, if you are growing Shiitake mushrooms, and a near-by fruiting of Oyster mushrooms generates spores that come into the laboratory, then the Oyster spores would be considered the “contaminant”. So the definition of a contaminant is a functional one—it being any organism you *don’t* want to culture.

The laboratory environment is a sanctuary, a precious space, to be protected from the turmoils of the outside world. Maintaining the cleanliness of a laboratory is less work than having to deal with the aftermath wreaked by contamination. Hence, contaminants, as soon as they appear, should be immediately isolated and carefully removed so neighboring media and cultures are not likewise infected.

## Overview of Techniques for Cultivating Mushrooms

The stages for cultivating mushrooms parallel the development of the mushroom life cycle. The mass of mycelium is exponentially expanded millions of times until mushrooms can be harvested. Depending upon the methodology, as few as two petri dishes of mushroom mycelium can result in 500,000-1,000,000 lbs. of mushrooms in as short as 12 weeks! If any contaminants exist in the early stages of the spawn production process, they will likewise be expanded in enormous quantities. Hence, the utmost care must be taken, especially at the

early stages of spawn production. Several tracks lead to successfully growing mushrooms. For indoor, high-intensity cultivation, three basic steps are required for the cultivation of mushrooms on straw (or similar material) and four for the cultivation of mushrooms on supplemented sawdust. Within each step, several generations of transfers occur, with each resulting in five-to hundred-fold increases in mycelial mass.

### I. Culturing Mycelium on Nutrified Agar

**Media:** Mushroom mycelium is first grown on sterilized, nutritied agar media in petri dishes and/or in test tubes. Once pure and grown out, cultures are transferred using the standard cut-wedge technique. Each culture incubating in 100 x 15 mm. petri dish can inoculate 10 quarts (liters) of grain spawn. (See Figure 63) If the mycelium is chopped in a high-speed stirrer and diluted, one petri dish culture can effectively inoculate 40-100 quarts (liters) of sterilized grain. These techniques are fully described in the ensuing pages.

**II. Producing Grain Spawn:** The cultures in the petri dishes can be expanded by inoculating sterilized grain housed in bottles, jars, or bags. Once grown out, each jar can inoculate 10 (range: 5-20) times its original mass for a total of three generations of expansions. Grain spawn can be used to inoculate pasteurized straw (or similar material) or sterilized sawdust. Grain spawn is inoculated into sawdust, straw, etc. at a rate between 3-15% (wet mass of spawn to dry mass of substrate).

**III. Producing Sawdust Spawn:** Sawdust spawn is inoculated with grain spawn. Sawdust spawn is best used to inoculate a “fruiting substrate”, typically logs or supplemented sawdust formulas. One 5 lb. bag of sawdust spawn can effectively inoculate 5-20 times its mass, with a recommended rate of 10:1. Sawdust-to-saw-



Figure 63. Creating and expanding grain spawn. Sterilized grain is first inoculated from agar-grown cultures. Once grown out, each jar can inoculate ten more every two weeks.

dust transfers are common when growing Shiitake, Nameko, Oyster, Maitake, Reishi or King Stropharia. Once grown out, each of these bags can generate 5-10 more sawdust spawn bags ( $S^1$  to  $S^2$ ). No more than two generations of expansion are recommended in the production of sawdust spawn.

#### **IV. Formulating the Fruiting Substrate:**

The fruiting substrate is the platform from which mushrooms arise. With many species, this is the final stage where mushrooms are produced for market. The formulas are specifically designed for mushroom production and are often nutrified with a variety of supplements. Some growers on bulk substrates expand the mycelium one more time, although I hesitate to

recommend this course of action. Oyster cultivators in Europe commonly mix fully colonized, pasteurized straw into ten times more pasteurized straw, thus attaining a tremendous amount of mycelial mileage. However, success occurs only if the utmost purity is maintained. Otherwise, the cultivator risks losing everything in the gamble for one more expansion.

This final substrate can be amended with a variety of materials to boost yields. With Shiitake, supplementation with rice bran (20%), rye flour (20%), soybean meal (5%), molasses (3-5%), or sugar (1% sucrose) significantly boosts yields by 20% or more. (For more information the effects of sugar supplementation on Shiitake yields, see Royse et al., 1990.)

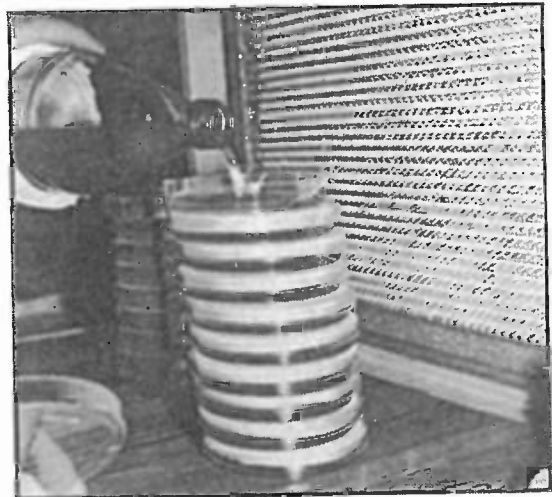
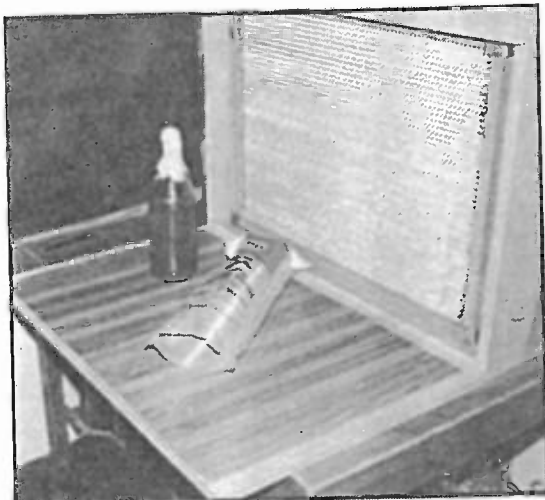
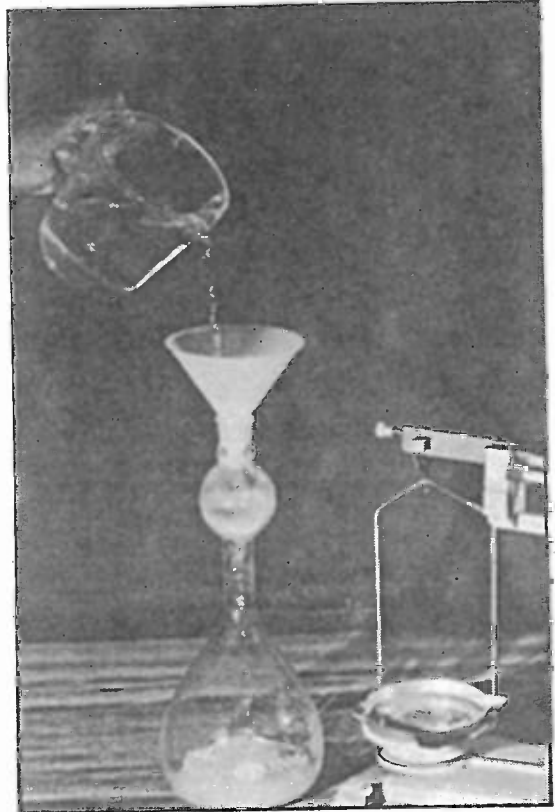
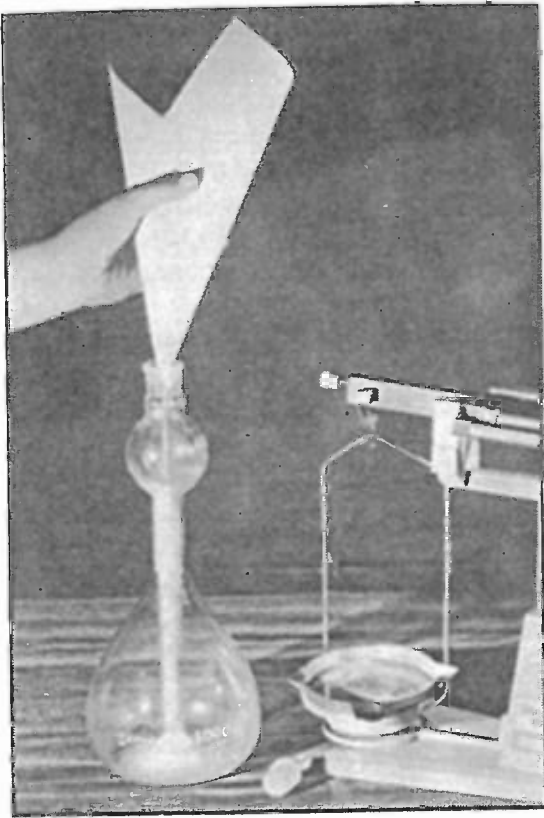

Figures 64, 65, 66 and 67. Preparing and pouring nutrified agar media into petri dishes. A variety of vessels can be used for media preparation.



# Culturing Mushroom Mycelium on Agar Media

## Preparing Nutrified Agar Media

**M**any formulations have been developed for the cultivation of mushrooms on a semi-solid agar medium. Agar is a seaweed-derived compound that gelatinizes water. Nutrients are added to the agar/water base which, after sterilization, promote healthy mushroom mycelium. The agar medium most commonly used with the greatest success is a fortified version of Malt Extract Agar (MEA). Other nutritified agar media that I recommend are: Potato Dextrose Agar (PDA), Oatmeal Agar (OMA), and Dog Food Agar (DFA).

By supplementing these formulas with yeast and peptone, essential vitamins and amino acids are provided. These supplements not only greatly stimulate the rate of growth, but the quality of the projected mycelial mat. Most agar media are simple and quick to prepare. What follows are some of my favorite nutritified agar recipes—of the 500 or more published.

**Malt Extract, Yeast Agar**

1000 milliliters (1 liter) water  
 20 grams agar agar  
 20 grams barley malt sugar  
 2 gram yeast (nutritional)  
 1 gram peptone (optional, soybean derived)

(The above medium is abbreviated as MYA. With the peptone, which is not critical for most of the species described in this book, this medium is designated MYP A.)

**Potato, Dextrose, Yeast Agar**

1000 milliliters (1 liter) water  
 300 grams of potatoes (i. e. the broth from boiling potatoes in 2-3 liters of water for 1 hour)  
 20 grams agar agar  
 10 grams dextrose  
 2 grams yeast  
 1 gram peptone (optional, soybean derived)

(This medium is designated PDYA, or PDYPA if peptone is added. Note that only the broth from boiling the potatoes is used—the potatoes are discarded. The total volume of the media should equal 1 liter.)

**Oatmeal, Malt, Yeast Enriched Agar**

1000 milliliters water (1 liter)  
 80 grams instant oatmeal  
 20 grams agar agar  
 10 grams malt sugar  
 2 grams yeast

(This rich medium is called OMYA. The oatmeal does not *have* to be filtered out although some prefer to do so.)

**Dog Food Agar**

1000 milliliters water (1 liter)  
 20 grams dry food\*  
 20 grams agar agar

\* Dog food was first used as a component for agar medium by the late Dr. Steven Pollock.

**Corn Meal, Yeast, Glucose Agar**

1000 milliliters water (1 liter)  
 20 grams agar agar  
 10 grams cornmeal  
 5 grams malt or glucose  
 1 gram yeast

(This medium is known as CMYA and is widely used by mycological laboratories for storing cultures and is not as nutritious as the other above-described formulas.)

The pH of the above media formulations, after sterilizing, generally falls between 5.5-6.8. This media can be further fortified with the addition of 3-5 grams of the end-substrate (in most cases hardwood sawdust) upon which mushrooms will be produced. If samples of soil or dung are desired, they first must be pre-boiled for 1-2 hours before adding to any of the above formulas. One potential advantage of the addition of these end-substrate components is a significant reduction in the "lag period." The lag period is seen when mushroom mycelium encounters unfamiliar components. (See Leatham & Griffin, 1984; Raaska 1990). This simple step can greatly accelerate the mushroom life cycle, decreasing the duration of colonization prior to fruiting.

The dry components are mixed together, placed into a flask, to which 1 liter of water is added. This cultivator finds that well-water, spring water, or mineral water works well. Chlorinated water is not recommended. Purchasing distilled water is unnecessary in my opinion. Once the media has been thoroughly mixed, the media flask is placed into a pressure cooker. The top of the media flask is either stopped with non-absorbent cotton, wrapped in aluminum foil, or, if equipped with a screw cap, the cap is loosely tightened. *Sterilize for 45 minutes @ 15 psi or @ 250° F.*

Pressure cookers or sterilizers that do not re-

lease pressure during the sterilization cycle are ideal. The old-fashioned pressure canners, those having weights sitting upon a steam valve, cause the media to boil as steam is vented. A huge mess ensues. The pressure cooker should ideally form a vacuum upon cool-down. If, upon returning to atmospheric pressure, a vacuum is not formed, the cultivator must place the pressure cooker in the clean room or open it in front of a laminar flow hood while it is still pressurized.

As the media cools within the pressure cooker, outside air is sucked in. If this air is laden with contaminant spores, the media contaminates before the cultivator has handled the flask! One precaution is to saturate a paper towel with alcohol and drape it over the point where outside air is being drawn in. The cloth acts as a filter, lessening the chance of contaminants. Twenty minutes after the heat source has been turned off, most media vessels can be handled without a hot-glove. Prior to that time, media can be poured, but some form of protection is needed to prevent burns to the hands.

Agar coagulates water when added in excess of 10 grams per 1000 ml. H<sub>2</sub>O. Only high grade agar should be used. Various agars differ substantially in their ability to gelatinize water, their mineral and salt content, as well as their endemic populations of micro-organisms, including bacteria. (Bacteria, if surviving, often de-gelatinize the media.) Increasingly, pollution has affected the refinement of tissue-grade agar, causing the price to spiral. Agar substitutes such as Gelrite™ are widely used by the plant tissue culture industry. Although only a few grams are needed per liter, it does not result in a media firm enough for most mushroom cultivators. Mushroom cultivators desire a media with a semi-solid, firm surface upon

which the mycelium will grow. Plant tissue culturists seek a softer, gelatinous form so that plant starts will grow three dimensionally, deep into the medium.

Sugars are essential for the healthy growth of mycelium. For media formulation, complex sources of sugars (carbohydrates and polysaccharides) are recommended. Cornsteep fermentative, cooked potatoes, wood, and barley malt extracts provide sugars and an assortment of basic minerals, vitamins, and salts helpful in the growth of the mushroom mycelium. From my experiences, simple sugars, while they may support growth, are not recommended as strains can not be maintained for long without promoting mutation factors, senescence, or loss of vitality.

A variety of nitrogen and carbohydrate based supplements can be added to fortify the media. Strains grown repeatedly on mono-specific media for prolonged periods risk limiting the repertoire of digestive enzymes to just that formulation. In other words, a strain grown on one medium adapts to it and may lose its innate ability to digest larger, more complex and variable substrates. To prevent a strain from becoming media-specific, the following compounds are added to 1 liter of MEA or PDA at various intervals, often in combinations:

### **Nitrogen & Carbohydrate Supplements**

- 2 grams yeast or
- 1-2 grams peptone
- 2 grams oatmeal, oat bran
- 2 gram rye or wheat flour
- 1 gram soybean meal
- 1 gram spirulina
- 2 grams high quality dry dog food

### End-Substrate Supplements

3-5 grams sawdust

3-5 grams powdered straw

3-5 grams sugar cane bagasse, etc.

Until some familiarity is established, the purchase of pre-mixed media from reputable companies is advised. Be forewarned, however, that the media designed for the growth of imperfect fungi, available from large laboratory supply companies, favors the growth of mold contaminants over that of mushroom mycelium. The media for most saprophytes should be adjusted to a pH of 5.5 to 6.5. Most saprophytes acidify substrates, so near neutral, even basic, substrates, become more acidic as the mushroom life cycle progresses.

### Pouring Agar Media

One liter of malt extract agar medium will pour 20-40 100 x 15 mm. petri dishes, depending upon the depth of the pour. Before pouring an

agar medium, the table top is thoroughly wiped clean with an 80% concentration of isopropanol (isopropyl alcohol). Plastic petri dishes usually come pre-sterilized and ready to use. Glass petri dishes should be first washed and sterilized in a petri dish-holding rack simultaneous to the sterilization of the agar medium in an autoclavable flask. Pre-pouring media into glass dishes and then sterilizing is awkward. Media separation occurs, and any movement during the sterilization cycle (or while transferring the pressure cooker to the clean room) causes the liquified media to spill out of the petri-dishes. A huge mess results. However, this problem can be avoided if the pressure cooker cools overnight, for instance, and is then opened the next day. Be forewarned that if you choose this alternative, your pressure cooker must either form a vacuum, safely protecting the media before opening, or be placed into a HEPA filtered airstream to prevent contamination entry during cool-down.

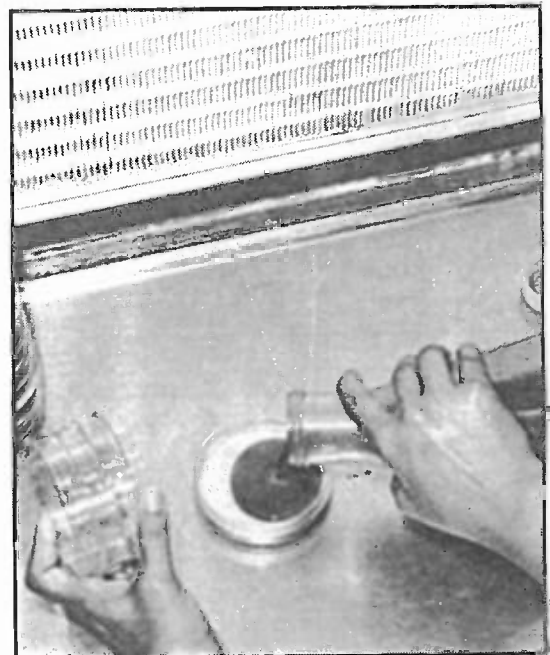
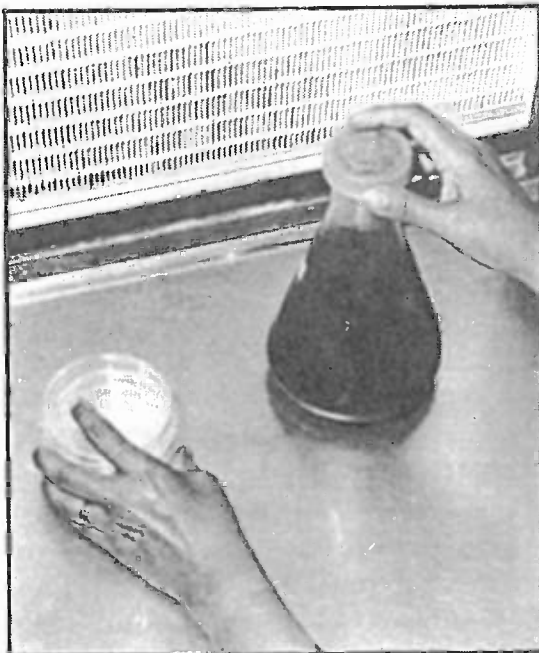

Figures 68-69. Pouring malt agar into sterile petri dishes in front of laminar flow hood.

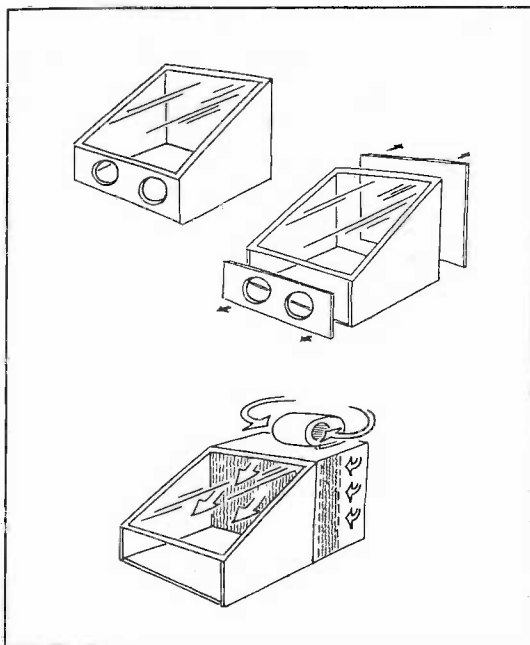

Figure 70. Glove boxes are considered “old tech”. To retrofit a glove box into a laminar flow hood, simply cut out the back panel, replace with a similarly sized HEPA filter and build a 6”-deep plenum behind the filter. A squirrel cage blower is mounted on top, forcing air into the plenum. Air is forced through the filter. Downstream from the filter, a sterile wind flows in which inoculations can be conducted.

With the micron filters mounted horizontally, and facing the cultivator, every movement is prioritized by degree of cleanliness. The cleanest articles remain upstream, the next cleanest downstream in second position, etc. The cultivator’s hands are usually furthest downwind from the media and cultures.

## Starting a Mushroom Strain by Cloning

The surest method of starting a mushroom strain is by cloning. Cloning means that a piece of pure, living flesh is excised from the mush-

room and placed into a sterilized, nutrient enriched medium. If the transfer technique is successful, the cultivator succeeds in capturing a unique strain, one exhibiting the particular characteristics of the contributing mushroom. These features, the expression thereof, are called the *phenotype*. By cloning, you capture the phenotype. Later, under the proper cultural conditions, and barring mutation, these same features are expressed in the subsequently grown mushrooms.

Several sites on the mushroom are best for taking clones. First, a young mushroom, preferably in “button” form, is a better candidate than an aged specimen. Young mushrooms are in a state of frenzied cell division. The clones from young mushrooms tend to be more vigorous. Older mushrooms can be cloned but have a higher contamination risk, and are slower to recover from the shock of transfer. Two locations resulting in a high number of successful clones are: the area directly above the gills, and the interior tissue located at the base of the stem. The stem base, being in direct contact with the ground, is often the entry point through which larvae tunnel, carrying with them other microorganisms. For this reason, I prefer the genetically rich area giving rise to the gills and their associated spore-producing cells, the basidia.

The procedure for cloning a mushroom is quite simple. Choose the best specimen possible, and cut away any attached debris. Using a damp paper towel, wipe the mushroom clean. Lay the specimen on a new sheet of paper towel. Flame-sterilize a sharp scalpel until it is red hot. Cool the scalpel tip by touching the nutrient agar medium in a petri dish. This petri dish will be the same dish into which you transfer the mushroom tissue. Carefully tear the mushroom apart from the base, up the stem, and through

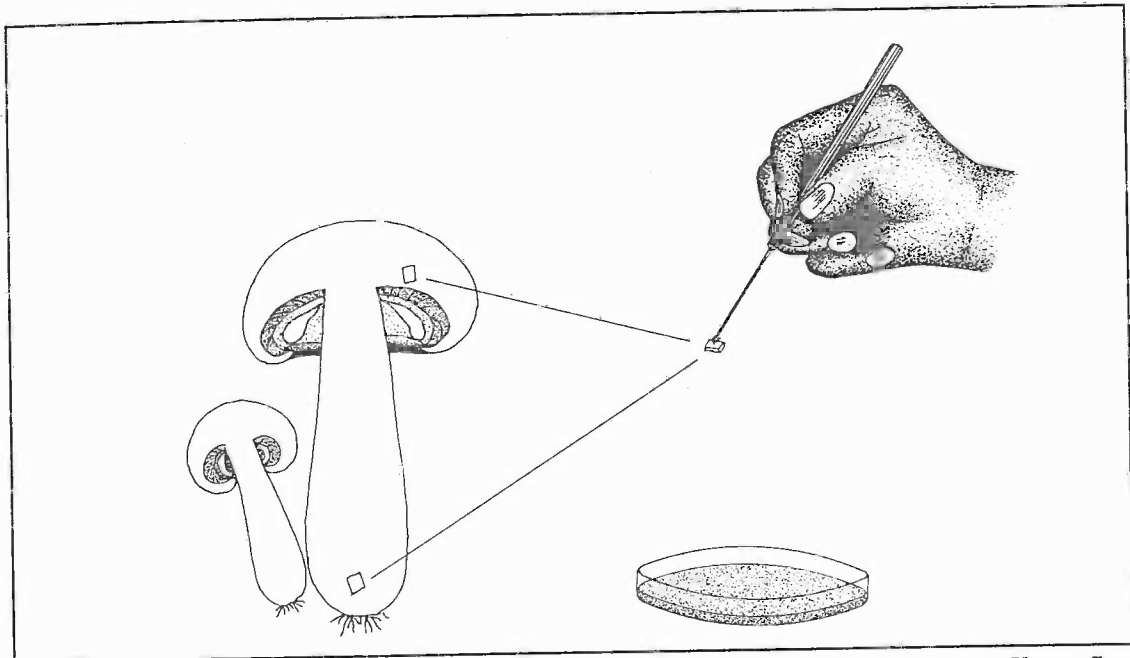

Figure 71. Ideal sites for cloning a mushroom: directly above the gills or at the base of the stem. Young, firm mushrooms are best candidates for cloning.

the cap. With one half of this split mushroom, cut a small section ("square") of flesh about the size of a kernel of grain. Quickly transfer the excised tissue to the nutrient-filled petri dish, and submerge the tissue into the same location where the scalpel tip had been cooled. By inserting the tissue part way into the agar medium, in contrast to resting it on the surface, the mushroom tissue has maximum contact with the life-stimulating nutrients. Each time a clone is taken, the scalpel is re-sterilized, cooled and then the tissue is transferred into a separate petri dish following the aforementioned steps.

One carefully keeps the hot scalpel tip and the freshly poured media plates upstream of the mushroom being cloned or the mycelium being transferred. Next downstream is the cultivator's hands. No matter how many times one has disinfected his hands, one should presume they are replete with con-

taminants. (To test this, wash your hands, disinfect your fingertips with alcohol and fingerprint newly poured media plates. In most cases, the plates will contaminate with a plethora of microorganisms.)

Some use a "cooling dish" into which the hot scalpel tip is inserted before touching the living flesh of a mushroom. Repeatedly cooling the scalpel tip into the same medium-filled petri dish before each inoculation is *not* recommended. A mistake with any inoculation could cause contamination to be re-transmitted with each transfer. If, for instance, a part of the mushroom was being invaded by *Mycogone*, a mushroom-eating fungus, one bad transfer would jeopardize all the subsequent inoculations. Only one cooling dish should be used for each transfer; the same dish that receives the cloned tissue. In this fashion, at least one potential cross-contamination vector is eliminated.

When cloning a mushroom for the first time, I recommend a minimum of 5 repetitions. If the mushroom specimen is rare, cloning into several dozen dishes is recommended. As the specimen dries out, viable clones become increasingly less likely. With the window of opportunity for cloning being so narrow, the cultivator should clone mushrooms within hours of harvesting. If the mushrooms must be stored, then the specimen should be refrigerated at 35-40° F. (1-5° C.). After three to four days from harvest, finding viable and clean tissue for cloning is difficult.

A few days to two weeks after cloning the mushroom, the tissue fragment springs to life, becoming fuzzy in appearance. Contaminants usually become visible at this stage. As a rule, the cultivator always transfers viable mycelium away from contamination, not the other way around. The essential concept here, is *that the*

*cultivator "runs" with the mycelium*, subculturing away from contamination as many times as is necessary until a pure culture is established.

Each transfer from an older petri dish culture to a newer petri dish moves upstream. The scalpel is brought into contact with heat. The tip is cooled into the dish destined to receive the mycelium. The lid of this dish is lifted, the scalpel is cooled, and then the lid is replaced. Next, the lid of the dish hosting the mature mycelium is opened. The mycelium is cut. The wedge is transferred to the newly poured media plate. With the lid replaced, the culture is labelled and moved aside. The process is repeated until a number of plates are inoculated.

As each lid is lifted, care is taken not to extend the fingers beyond the lip of each top. The overhanging of fingers results in off-flaking of contaminants into the petri dish. Furthermore, the lids are lifted with their undersides catch-

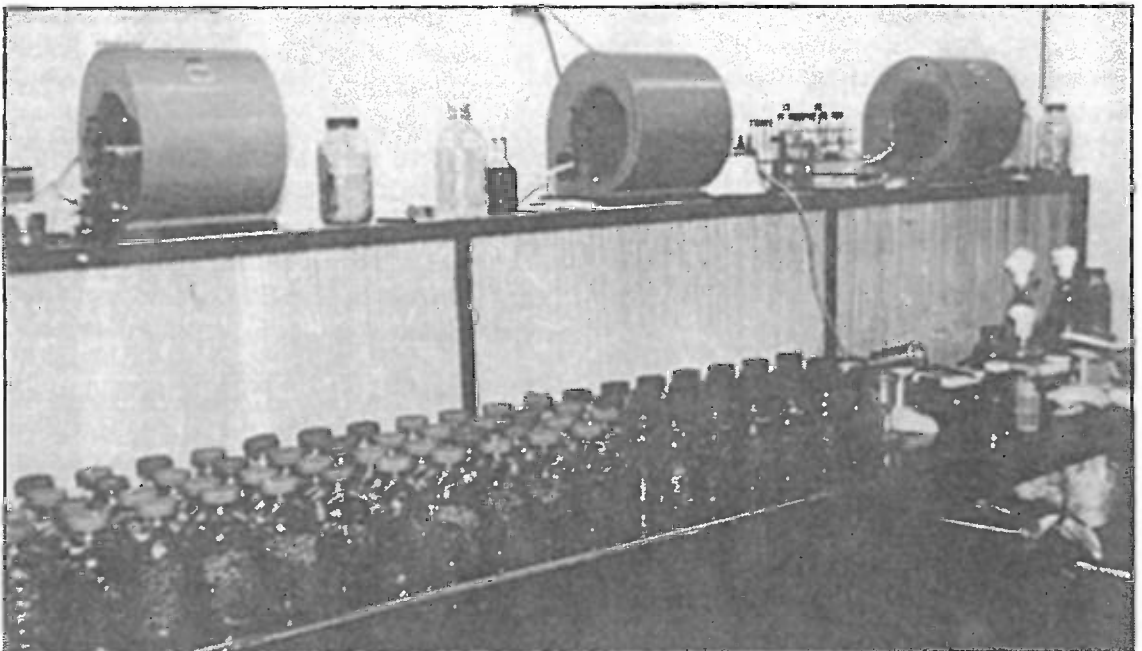

Figure 72. Paul Stamets' simple, effective 12 ft. long, laminar flow bench designed for commercial cultivation.

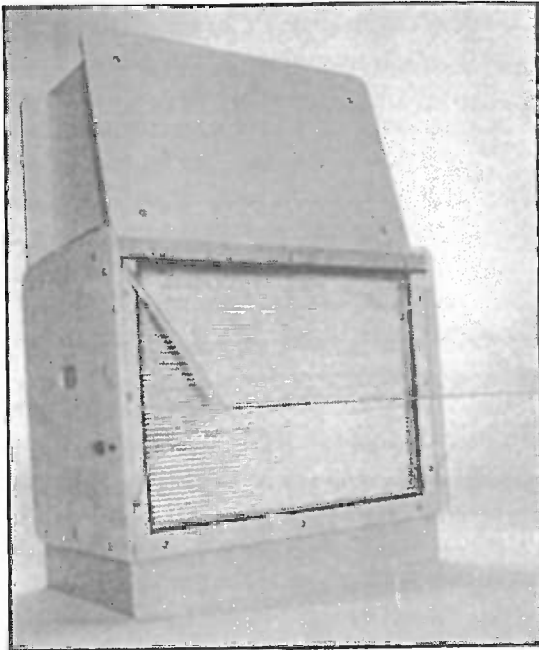

Figure 73. A laminar flow bench suitable for home or small-scale commercial cultivation.

ing the sterile airstream. If the lids must be laid down, they are positioned undersides up, upstream of the operations area, so that contaminants are not picked up off the table. Always presume the air coming off the face of the micron filter is cleaner than the work surface in front of it.

Culture transfers that are fast, evenly repeated, and in quick succession usually are the most successful. The simplest acts dramatically impact sterile technique. Merely breathing over exposed petri dishes significantly affects contamination levels. Singing, for instance, is associated with a high rate of bacterial contamination. One bewildered professor discovered that her soliloquies in the laboratory—she sang as the radio blared—were a direct cause of high contamination rates. An alert student discovered her digression from sterile technique upon

passing the door to her lab. This illustrates that the cultivator's unconscious activities profoundly influence the outcome of tissue culture transfers. *Every action in the laboratory has significance.*

### Cloning Wild Specimens vs. Cloning Cultivated Mushrooms

Many people ask "What is wrong with just cloning a nice looking specimen from each crop of cultivated mushrooms to get a new strain?" Although morphological traits can be partially selected for, senescence factors are soon encountered. Generating mycelium in this fashion is a fast-track to genetic demise, quickly leading to loss of vigor and yield. By not returning to stock cultures, to young cell lines, one has gone furthest downstream one linear chain of cells. Mushrooms, like every sexually reproducing organism on this planet, can generate a limited number of cell divisions before vitality falters. Sectoring, slow growth, anemic mushroom formation, malformation, or no mushroom formation at all, are all classic symptoms of senescence. Although senescence is a frequently encountered phenomenon with cultivators, the mechanism is poorly understood. (See Kuck et al., 1985.)

In the competitive field of mycology, strains are all-important. With the aforesaid precautions and our present day technologies, strains can be preserved for decades, probably centuries, all-the-while kept within a few thousand cell divisions from the original culture. Since we still live in an era of relatively rich fungal diversity, the time is now to preserve as many cell lines from the wild as possible. As bio-diversity declines, the gene pool contracts. I strongly believe that the future health of the planet may well depend upon the strains we preserve this century.



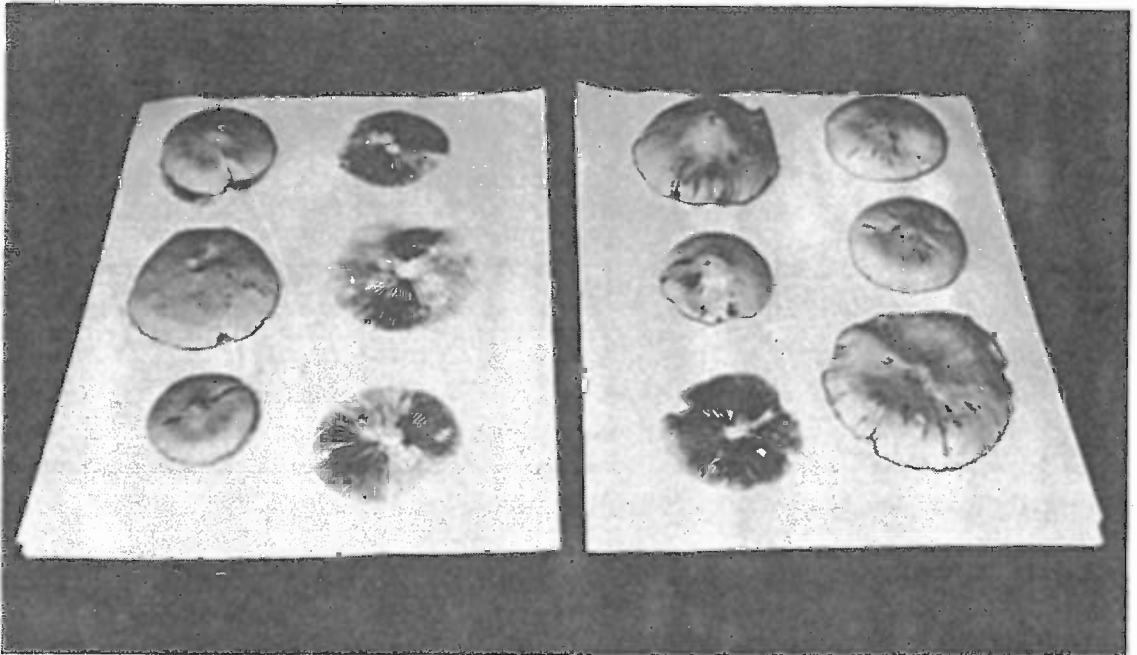

Figure 74. Taking spore prints on typing paper.

## How to Collect Spores

A culture arising from cloning is fundamentally different than a culture originating from spores. When spores are germinated, many different strains are created, some incompatible with one another. A cultivator will not know what features will be expressed until each and every strain is grown out to the final stage, that of mushroom production. This form of genetic roulette results in very diverse strains, some more desirable than others.

Mushroom spores are collected by taking a *spore print*. Spore prints are made by simply severing the cap from the stem, and placing the cap, gills down, upon a piece of typing paper, or glass. Covering the mushroom cap with a bowl or plate lessens evaporation and disturbance from air currents. Within 24 hours spores fall in a beautiful pattern according to the radi-



Figure 75. The spore print can be folded and rubbed together so that spores drop onto nutrient agar media. This method is not the best as concentrated populations of spores are grouped together.

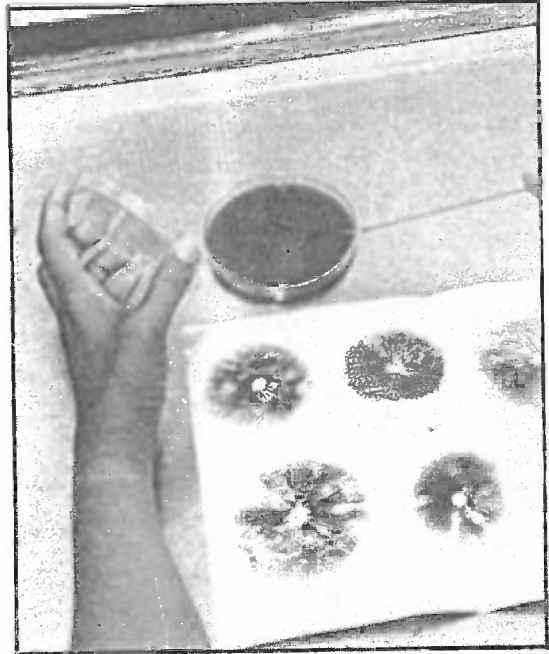
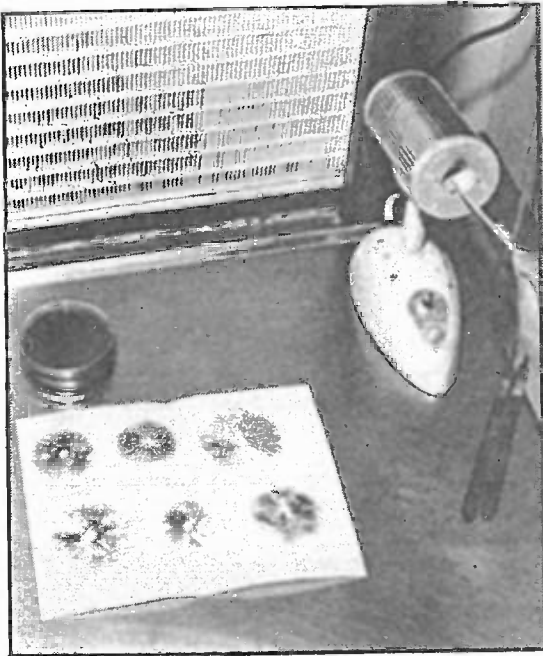

Figures 76–79. An inoculation loop is sterilized, in this case with a BactiCinerator™, and then cooled into the “receiving” dish. The spores are picked up by touching the inoculation loop to the spore print. The spore-laden inoculation loop is streaked across the surface of the sterilized, nutrient-filled medium in an “S” pattern.



Figures 80. Spores germinate according to the streaking pattern. A small portion is excised and transferred to a new, nutrient agar-filled petri dish.

ating symmetry of the gills. (See Figure 74.) A single mushroom can produce from tens of thousands to a hundred million spores!

I prefer to collect spores on plates of glass, approximately 6 x 8 inches. The glass is washed with soapy water, wiped dry, and then cleaned with rubbing alcohol (isopropanol). The two pieces of glass are then joined together with a length of duct tape to create, in effect, a binding. The mushrooms are then laid on the cleaned, open surface for spore collection. After 12-24 hours, the contributing mushroom is removed, dried, and stored for reference purposes. (See Figure 15.) The remaining edges of the glass are then taped. The result is a glass-enclosed "Spore Booklet" which can be stored at room temperature for years. Spores are easily removed from the smooth glass surface for future use. And, spores can be easily observed without increasing the likelihood of contami-

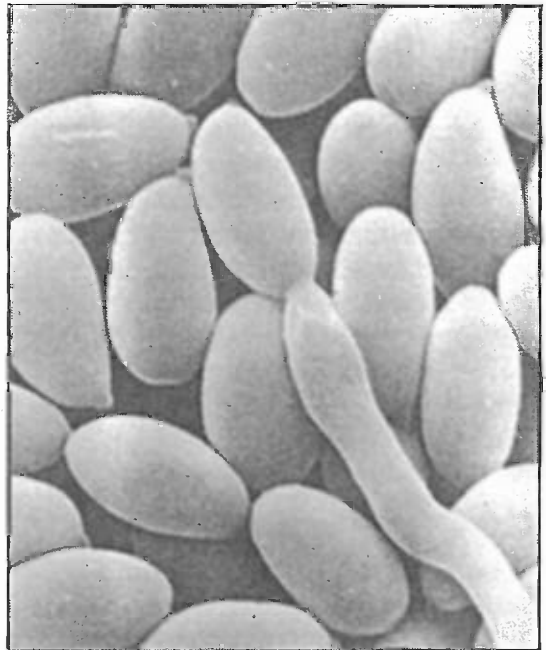

Figure 81. Scanning electron micrograph of spores germinating.



Figure 82. Scanning electron micrograph of spores infected with bacteria.

nation.

Spores have several advantages. Once a spore print has been obtained, it can be sealed and stored, even sent through the mail, with little ill effect. For the traveller, spore prints are an easy way to send back potential new strains to the home laboratory. Spores offer the most diverse source of genetic characteristics, far more than the phenotypic clone. If you want the greatest number of strains, collect the spores. If you want to capture the characteristics of the mushroom you have found, then clone the mushroom by cutting out a piece of living tissue.

## Germinating Spores

To germinate spores, an inoculation loop, a sterilized needle, or scalpel is brought into contact with the spore print. (I prefer an inoculation loop.) I recommend flame sterilizing an inocu-

lation loop until red hot and immediately cooling it in a petri dish filled with a sterilized nutrient medium. The tip immediately sizzles as it cools. The tip can now touch the spore print without harm, picking up hundreds of spores in the process. (By touching the tip to the medium-filled petri dish first, not only is it cooled, but the tip becomes covered with a moist, adhesive layer of media to which spores easily attach.) The tip can now be streaked in an "S" pattern across the surface of another media dish. With heavy spore prints, the "S" streaking technique may not sufficiently disperse the spores. In this case, the scalpel or inoculation loop should be immersed into a sterile vial holding 10 cc. (ml.) of water. After shaking thoroughly, one drop (or 1/10th of 1 cc.) is placed onto the surface of the nutrient medium in each petri dish. Each dish should be tilted back and forth so that the spore-enriched droplet streaks across the surface, leaving a trail of dispersed spores. In either case, spores will be spread apart from one another, so that individual germinations can occur.

Five days later, spores may be seen germinating according to the streaking pattern. Colonies of germinating spores are subcultured into more petri dishes. (See Figure 80.) After the mycelium has grown away from the subculture site, a small fragment of pure mycelium is again subcultured into more petri dishes. If these cultures do not sector, then back-ups are made for storage and future use. This last transfer usually results in individual dikaryotic strains which are labelled. Each labelled strain is then tested for productivity. Mini-culture experiments must be conducted prior to commercial-level production.

When a concentrated mass of spores is germinated, the likelihood of bacteria and weed fungi infesting the site is greatly increased. Bacteria replicate faster than mushroom spores can germinate. As a result, the germinating spores

become infected. (See Figure 81.) Mycelium arising from such germinations are frequently associated with a high contamination rate, unfortunately often not experienced until the mycelium is transferred to grain media. However, if the spore prints are made correctly, contamination is usually not a problem.

Once inoculated, the petri dish cultures should be taped with an elastic film (such as Parafilm™) which protects the incubating mycelium from intrusive airborne contaminants. (See Figure 58.)

### Purifying a Culture

Many cultures originating from spores or tissue are associated with other micro-organisms. Several techniques are at one's disposal for cleaning up a culture. Depending upon the type and level of contamination, different measures are appropriate.

One way of cleaning a bacterially infested culture is by sandwiching it between two layers of media containing an antibiotic such as gentamycin sulfate. The hyphae, the cells composing the mycelium, are arranged as long filaments. These filamentous cells push through the media while the bacteria are left behind. The mycelium arising on the top layer of media will carry a greatly reduced population of bacteria, if any at all. Should the culture not be purified the first time using this procedure, a second treatment is recommended, again subculturing from the newly emerged mycelium. Repeated attempts increase the chances of success.

If the culture is mixed with other molds, then the pH of the media can be adjusted to favor the mushroom mycelium. Generally speaking, many of the contaminant fungi are strong acidophiles whereas Oyster mushrooms grow well in environments near to a neutral pH. If these mold fungi sporulate adjacent to the

mycelia of mushrooms, isolation becomes difficult. \* Remember, the advantage that molds have over mushroom mycelia is that their life cycles spin far faster, and thousands of mold spores are generated in only a few days. Once molds produce spores, any disturbance—including exposure to the clean air coming from the laminar flow hood—creates satellite colonies.

One rule is to immediately subculture all points of visible growth away from one another as soon as they become visible. This method disperses the colonies, good and bad, so they can be dealt with individually. Repeated subculturing and dispersal usually results in success. If not, then other alternative methods can be implemented.

Mycelia of all fungi grow at different rates and are acclimated to degrading different base materials. One method I have devised for separating mushroom mycelium from mold mycelium is by racing the mycelia through organic barriers. Glass tubes can be filled with finely chopped, moistened straw, wood sawdust, even crushed corncobs (without kernels) and sterilized. The contaminated culture is introduced to one end of the tube. The polyculture of contaminants of mushroom mycelium races through the tube, and with luck, the mushroom mycelium is favorably selected, reaching the opposite end first. At this point, the cultivator simply transfers a sample of emerging mycelium from the end of the tube to newly poured media plates. The cultures are then labelled, sealed and ob-

\* The spores of most mold fungi become distinctly pigmented at maturity. Some *Penicillium* molds are typically blue-green. *Aspergillus* species range in color from black to green to yellow. *Neurospora* can be pink. A few molds, such as *Monilia* or *Verticillium*, produce white colonies. For more information on these competitors, please consult *The Mushroom Cultivator* (1983) by Stamets & Chilton.

served for future verification. This technique relies on the fact that the mycelia of fungi grow at different rates through biodegradable materials. The semi-selectivity of the culture/host substrate controls the success of this method.

Every cultivator develops his own strategies

for strain purification. Having to isolate a culture from a background of many contaminants is inherently difficult. Far easier it is to implement the necessary precautions when initially making a culture so that running away from contamination is unnecessary.

# The Stock Culture Library: A Genetic Bank of Mushroom Strains

**E**very sexually reproducing organism on this planet is limited in the number of its cell replications. Without further recombination of genes, cell lines decline in vigor and eventually die. The same is true with mushrooms. When one considers the exponential expansion of mycelial mass, from two microscopic spores into tons of mycelium in a matter of weeks, mushroom mycelium cell division potential far exceeds that of most organisms. Nevertheless, strains die and, unless precautions have been taken, the cultures may never be retrieved.

Once a mushroom strain is taken into culture, whether from spores or tissue, the resultant strains can be preserved for decades under normal refrigeration, perhaps centuries under liquid nitrogen. In the field of mycology, cultures are typically stored in test tubes. Test tubes are filled with media, sterilized and laid at a 15-20 degree angle on a table to cool. (Refer to Chapter 12 for making sterilized media.) These are called *test tube slants*. Once inoculated, these are known as *culture slants*.

Culture slants are like “back-ups” in the computer industry. Since every mushroom strain is certain to die out, one is forced to return to the stock library for genetically younger copies. Good mushroom strains are hard to come by, compared to the number of poor performers isolated from nature. Hence, the Culture Library, a.k.a. the Strain Bank, is the pivotal center of any mushroom cultivation enterprise.

## Preserving the Culture Library

One culture in a standard 100 x 15 mm. petri dish can inoculate 50-100 test tube slants measuring 100 x 20 mm. After incubation for 1-4 weeks, or until a luxurious mycelium has been established, the test tube cultures are placed into cold storage. I seal the gap between the screw cap and the glass tube with a commercially available elastic, wax-like film. (Those test tube slants not sealed with this film are prone to contaminate with molds after several months of cold storage.) Culture banks in Asia commonly preserve cultures in straight test tubes whose ends are stuffed with a hydrophobic cotton or gauze. The gauze is sometimes covered with plastic film and secured tightly with a rubber band. Other libraries offer cultures in test tubes fitted with a press-on plastic lid especially designed for gas exchange. The need for gas exchange is minimal—provided the culture’s growth is slowed down by timely placement into cold storage. Culture slants stored at room temperature have a maximum life of 6-12 months whereas cultures kept under refrigeration survive for 5 years or more. Multiple back-ups of each strain are strongly recommended as there is a natural attrition over time.

I prefer to seal test-tube slants in plastic zip-lock bags. Three to four bags, each containing 4 slants,



Figure 83. Stock Cultures, in quadruplicate, sealed in a plastic bag, stored in a cedar box, and refrigerated for years at 35° F. (1-2° C.) until needed.

are then stored in at least two locations remote from the main laboratory. This additional safety precaution prevents events like fires, electrical failure, misguided law enforcement officials, or other natural disasters from destroying your most valuable asset—**The Culture Library**.

Household refrigerators, especially modern ones, suffice. Those refrigerators having the greatest mass, with thermostatic controls limiting variation in temperature, are best for culture storage. With temperature variation, condensation occurs within the culture tubes, spreading a contaminant, should it be present, throughout the culture. Therefore, limiting temperature fluctuation to 2-3° F. (1° C.) is crucial for long term culture preservation. Furthermore, when mushroom cultures freeze and thaw repeatedly, they die.



If one has ten or more replicates, stock cultures of a single strain can be safely stored for 5 years by this method. As a precaution, however, one or two representative culture slants should be retrieved every year, brought to room temperature for 48 hours, and subcultured to newly filled media dishes. Once revived, and determined to be free of contamination, the mycelium can once again be subcultured back into test tube slants, and returned to refrigeration. *This circular path of culture rotation ascertains viability and prolongs storage with a minimum number of cell divisions. I can not over-emphasize the importance of maintaining cell lines closest to their genetic origins.*

Cryogenic storage—the preservation of cultures by storage under liquid nitrogen—is the best way to preserve a strain. Liquid nitrogen storage vessels commonly are held at  $-302^{\circ}\text{F}$ .

( $-150^{\circ}\text{C}$ ). Test tubes slants filled with a specially designed cryoprotectant media help the mycelium survive the shock of sudden temperature change. (Such cryoprotectants involve the use of a 10% glycerol and dextrose media.) Wang and Jong (1990) discovered that a slow, controlled cooling rate of  $-1$  degrees C. per minute resulted in a higher survival rate than sudden immersion into liquid nitrogen. This slow reduction in temperature allowed the mycelium to discharge water extracellularly, thus protecting the cells from the severe damage ice crystals pose. Further, they found that strains were better preserved on grain media than on agar media. However, for those with limited liquid nitrogen storage space and large numbers of strains, preservation on grain media is not as practical as preserving strains in ampules or test tubes of liquid cryoprotectant

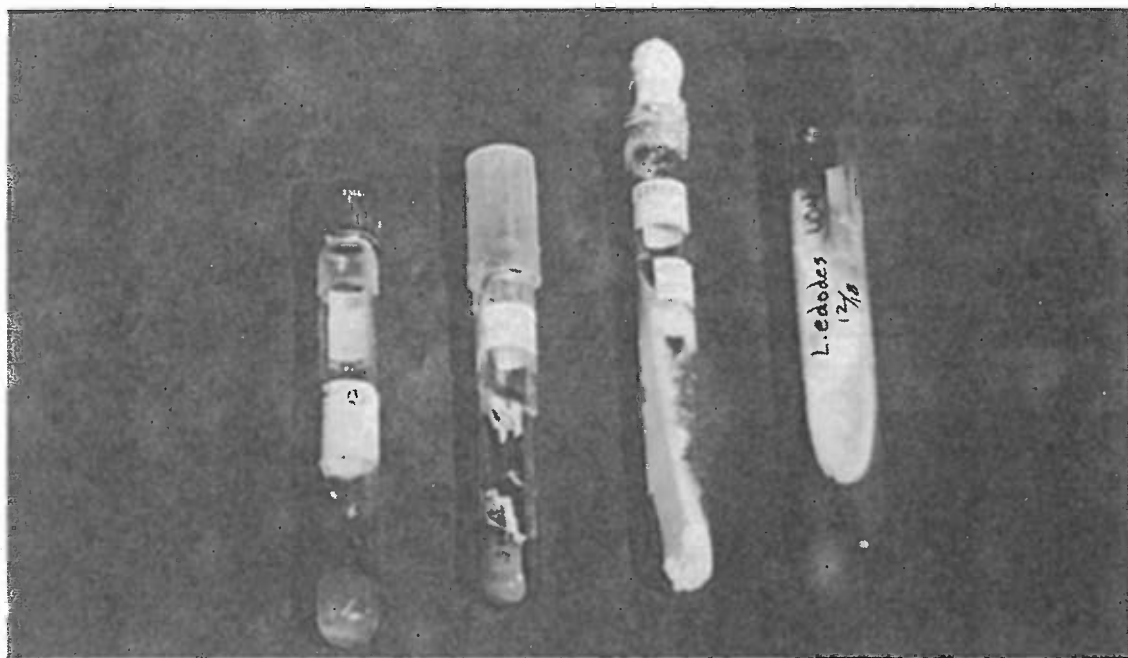

Figure 84. Examples of cultures originating from stock culture libraries from sources in United States, Canada, Thailand, and China. Most culture libraries do not send cultures in duplicate nor indicate how far the cultures have grown since inception.

media.

Of all the mushrooms discussed in this book, only strains of the Paddy Straw Mushroom, *Volvariella volvacea*, should not be chilled. *V. volvacea* demonstrates poor recovery from cold storage—both from simple refrigeration at 34° F. (2° C.) or immersion in liquid nitrogen at -300° F. (-150° C.). When the mycelium of this tropical mushroom is exposed to temperatures below 45° F. (7. 2° C.) drastic die-back occurs. Strains of this mushroom should be stored at no less than 50° F. (10° C.) and tested frequently for viability. When cultures are to be preserved for prolonged periods at room temperature, many mycologists cover the mycelium with liquid paraffin. (For more information, consult Jinxia and Chang, 1992).

When retrieving cultures from prolonged storage, the appearance of the cultures can immediately indicate potential viability or clear inviability. If the mycelium is not aerial, but is flat, with a highly reflective sheen over its surface, then the culture has likely died. If the culture caps have not been sealed, contaminants, usually green molds, are often visible, giving the mycelium a speckled appearance. These cultures make re-isolation most difficult. Generally speaking, success is most often seen with cultures having aerial, cottony mycelium. Ultimately however, cultivators can not determine viability of stored cultures until they are subcultured into new media and incubated for one to three weeks.

### The Stamets "P" Value System for Age Determination of a Strain

The Stamets "P" value system is simply an arithmetic scale I have devised for measuring the expansion of mycelium through successive

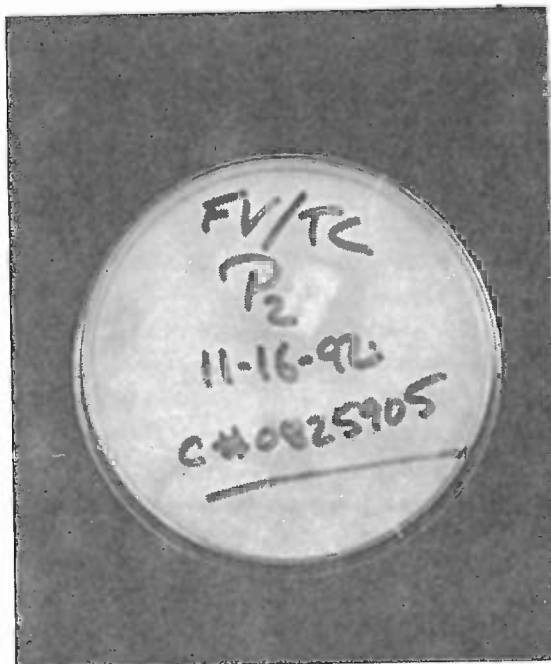

Figure 85. An Enokitake (*Flammulina velutipes*) culture is labelled to indicate genus, species, variety, "P" value, voucher collection number, and—if necessary—type of medium.

inoculations from one 100 x 15 mm. petri dish to the next. The number of cells divisions across a petri dish is affected by the range of cell wall lengths. Of the septate strains of fungi, some have cells as short as 20  $\mu$  while others have cells 200  $\mu$  and longer. The Stamets "P" Value (SPV) benefits cultivators by indicating how close to the origin their culture is at any point in time by simply recording the number of petri dishes the mycelium has grown across. When a culture has been isolated from contaminants, usually in one or two transfers, the first pure culture is designated as P<sub>1</sub>. When the mycelium has filled that dish, the next dish to receive the mycelium is called P<sub>2</sub>. Each culture is labelled with the date, species, collection number, strain code, P-Value and medium (if necessary). Thus, a typical example from one of my culture dishes

reads:

FV/TC P<sub>2</sub>  
11/16/92  
C # 0825905

This means: the strain, *Flammulina velutipes* isolated from Telluride, Colorado, has grown out over two petri dishes since its inception (in this case 8/90). The collection number refers to the date the mushrooms were collected in the wild: it was the fifth group of mushrooms found that day. (Others sequentially list their collections, from 1 to infinity.) The culture should be referenced to a dried voucher specimen from which the strain was generated. The dried specimens are either kept in your own private herbarium, or, better yet, deposited in an academically recognized herbarium which cross-indexes collections by date, species name, and collector. Keeping a voucher collection is critical so future researchers can commonly refer to the same physical standard.

The date "11/16/92" refers to the time the medium was inoculated. Spawn created from such young cultures, in contrast to one grown out twenty times as far, gives rise to more highly productive mycelium. The "P" value system is essentially a metric ruler for measuring relative numbers of cell divisions from the culture's birth. (Note that a square centimeter of mycelium is generally transferred from one culture dish to the next.) I have strains in my possession, from which I regularly regenerate cultures, which are ten years old and kept at a P<sub>2</sub> or P<sub>3</sub>. Having ten to twenty back-up culture slants greatly helps in this pursuit.

For purposes of commercial production, I try to maintain cell lines within P<sub>10</sub>, that is, within 10 successive transfers to medium-filled petri dishes. Many strains of Morels, Shiitake and King Stropharia express mutations when trans-

ferred on media for more than 10 petri dishes. Morels seem particularly susceptible to degeneration. *Morchella angusticeps* loses its ability to form micro-sclerotia in as few as 6 or 7 plate transfers from the original tissue culture.

The slowing of mycelium may also be partly due to media specificity, i. e. the agar formula selectively influences the type of mycelial growth. To ameliorate degenerative effects, the addition of extracted end-substrates (sawdust, straw, etc.) favors the normal development of mycelium. The introduction of the end-substrate acquaints the mushroom mycelium with its destined fruiting habitat, challenging the mycelium and selectively activating its enzymatic systems. This familiarity with the end-substrate greatly improves performance later on. Parent cells retain a "genetic memory" passed downstream through the mycelial networks. Mycelia grown in this fashion are far better prepared than mycelia not exposed to such cultural conditions. Not only is the speed of colonization accelerated, but the time to fruiting is shortened. Only 1-3 grams of substrate is recommended per liter of nutrient medium. Substrates high in endospores (such as manures or soils) should be treated by first boiling an aqueous concoction for at least an hour. After boiling, sugar, agar and other supplements are added, and the media is sterilized using standard procedures described in Chapter 12.

By observing the cultures daily, the change-over of characteristics defines what is healthy mycelium and what is not. This book strives to show the mycelium of each species and its transformations leading to fruiting. Variations from the norm should alert the cultivator that the strain is in an active state of mutation. Rarely do mutations in the mycelium result in a stronger strain.

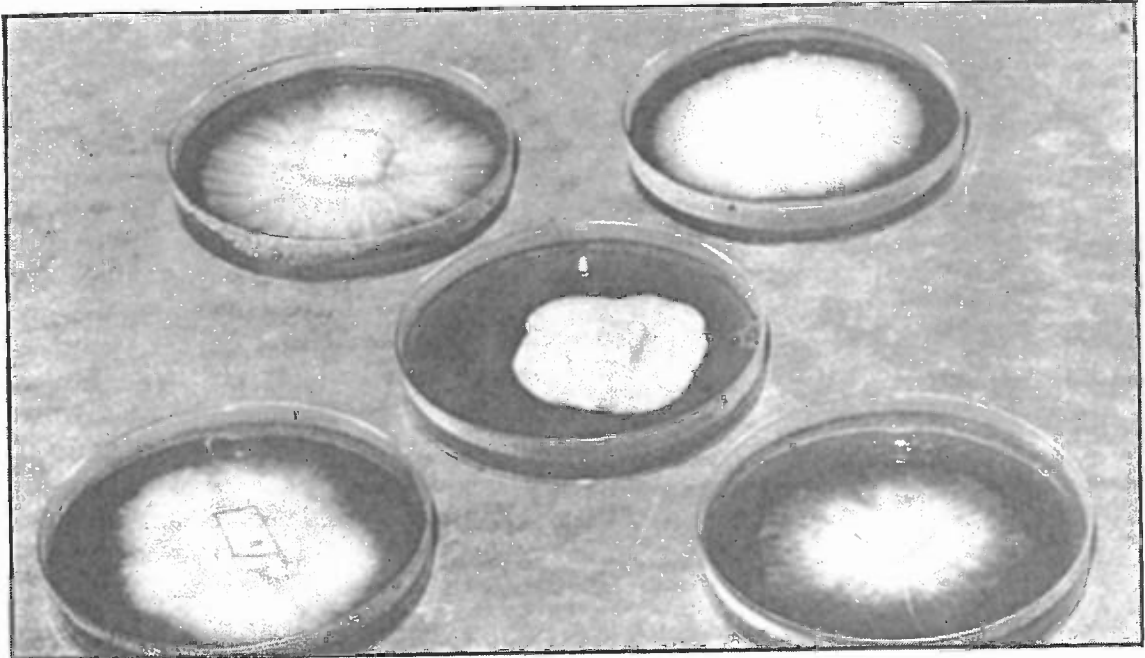

Figure 86. Classic forms of mushroom mycelia.

## Iconic Types of Mushroom Mycelium

Each mushroom species produces a recognizable type of mycelium whose variations fall within a range of expressions. Within a species, multitudes of strains can differ dramatically in their appearance. In culture, mushroom strains reveal much about the portion of the mushroom life cycle which is invisible to the mere forager for wild mushrooms. This range of characteristics—changes in form and color, rate of growth, fragrance, even volunteer fruitings of mushrooms in miniature—reveals a wealth of information to the cultivator, defining the strain's "personality".

**Form:** Mycelia can be categorized into several different, classic forms. For ease of explanation, these forms are delineated on the basis of their macroscopic appearance on the two

dimensional plane of a nutrient-filled petri dish. As the mycelium undergoes changes in its appearance over time, this progression of transformations defines what is normal and what is abnormal. The standard media I use is Malt Yeast Agar (MYA) often fortified with peptone (MYPA).

1. *Linear:* Linear mycelium is arranged as diverging, longitudinal strands. Typically, the mycelium emanates from the center of the petri dish as a homogeneously forming mat. Shiitake (*Lentinula edodes*) and initially Oyster (*Pleurotus ostreatus*) mycelia fall in this category. Morels produce a rapidly growing, finely linear mycelium, which thickens in time. In fact, Morel mycelium is so fine that during the first few days of growth, the mycelium is nearly invisible, detected only by tilting the petri dish back and forth so that the fine strands can be seen on the reflective sheen of the agar

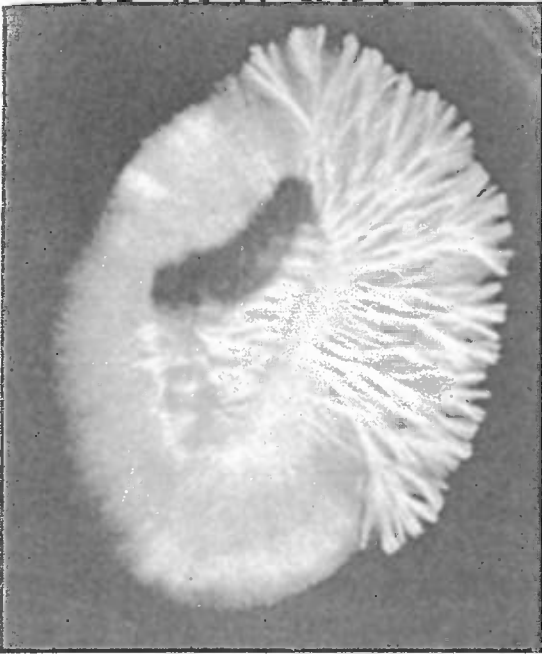

Figure 87. Rhizomorphic mycelium diverging from cottony mycelium soon after spore germination.

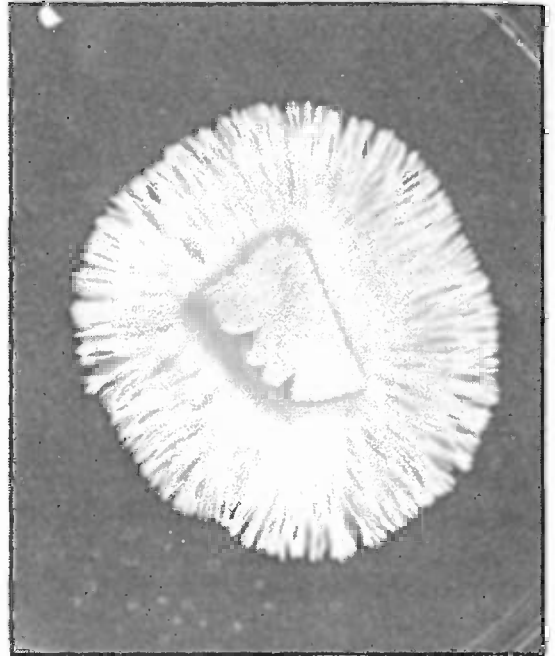

Figure 88. Classic rhizomorphic mycelium.

medium's surface.

2. *Rhizomorphic*: Often similar to linear mycelium, rhizomorphic mycelium is often called "ropey". In fact, rhizomorphic mycelium is composed of braided, twisted strands, often of varying diameters. Rhizomorphic mycelium supports primordia. Its presence is encouraged by selecting these zones for further transfer. The disappearance of rhizomorphs is an indication of loss of vigor. Lion's Mane (*Hericium erinaceus*), the King Stropharia (*Stropharia rugoso-annulata*), the Button Mushrooms (*Agaricus brunnescens*, *Agaricus bitorquis*), the Magic Mushrooms (*Psilocybe cubensis* and *Psilocybe cyanescens*), and the Clustered Woodlovers (*Hypholoma capnoides* and *H. sublateritium*) are examples of mushrooms producing classically rhizomorphic mycelia. Some types of rhizomorphic mycelia take on a reflec-

tive quality, resembling the surface of silk.

3. *Cottony*: This type of mycelium is common with strains of Oyster Mushrooms (*Pleurotus* species), Shaggy Manes (*Coprinus comatus*), and Hen-of-the-Woods (*Grifola frondosa*). Looking like tufts of cotton, the mycelium is nearly aerial in its growth. Cottony mycelium is commonly called tomentose by mycologists. When a rhizomorphic mycelium degenerates with age, tomentose formations typically take over.

4. *Zonate*: Cottony mycelium often shows concentric circles of dense and light growth, or zones. Zonate mycelium is often characteristic of natural changes in the age of the mycelium. The newest mycelium, on the periphery of the culture, is usually light in color. The more-aged mycelium, towards the center of the culture, becomes strongly pigmented.

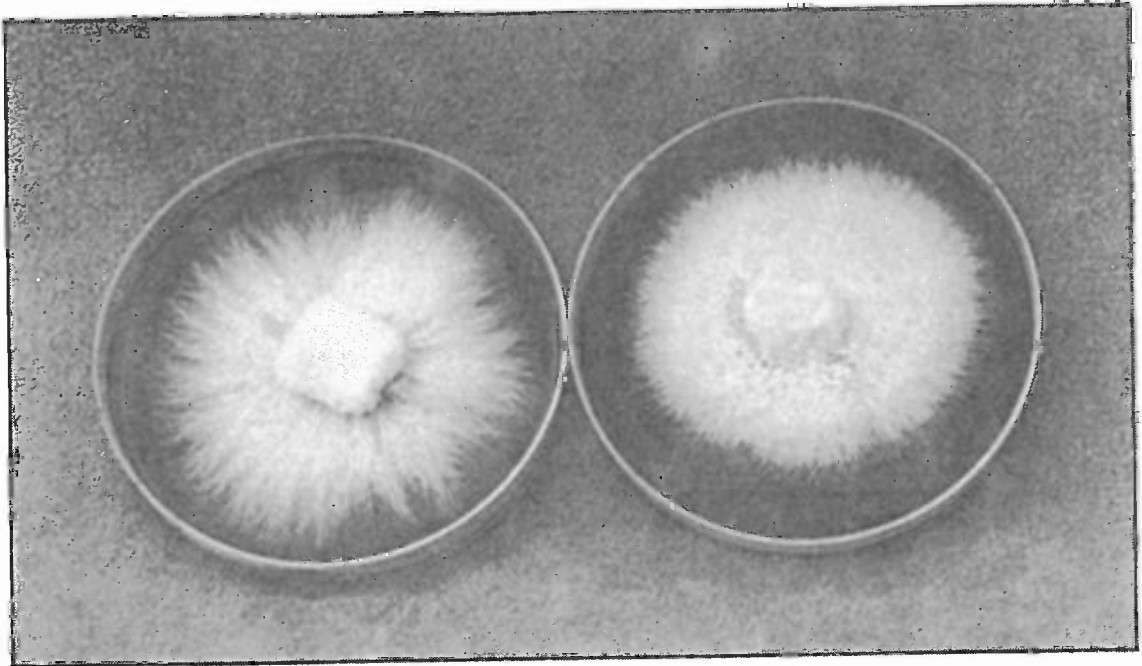

Figure 89. Quasi-rhizomorphic and cottony mycelia.

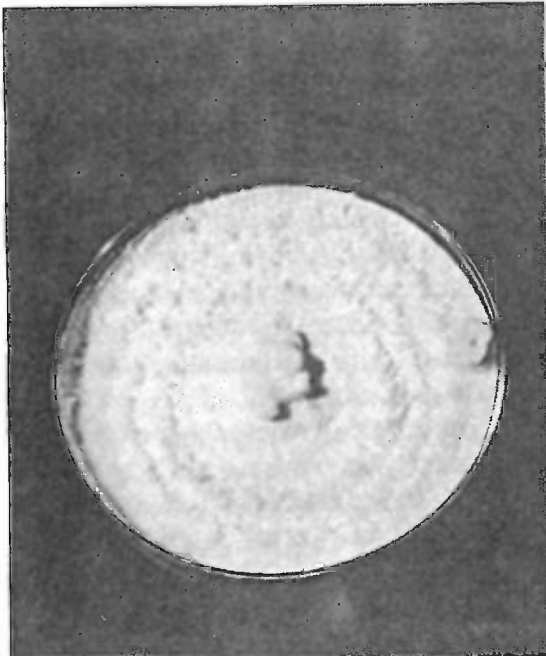

Figure 90. Zonate mycelium.

Zonations can also be a function of the natural, circadian cycles, even when cultures are incubated in laboratories where the temperatures are kept constant. Growth occurs in spurts, creating rings of growth. This feature is commonly seen in species of *Ganoderma*, *Hypholoma* and *Hypsizygos*.

5. *Matted or appressed*: This type of mycelium is typical of Reishi (*Ganoderma lucidum*) after two weeks of growth on 2% malt-extract agar media. So dense is this mycelial type that a factory-sharpened surgical blade can't cut through it. The mycelium tears off in ragged sheaths as the scalpel blade is dragged across the surface of the agar medium. Many species develop matted mycelia over time, especially the wood rotters. Cultures that mysteriously die often have mycelium which appears matted but whose surface is flat and highly reflective.

6. *Powdered*: This form of mycelium is best

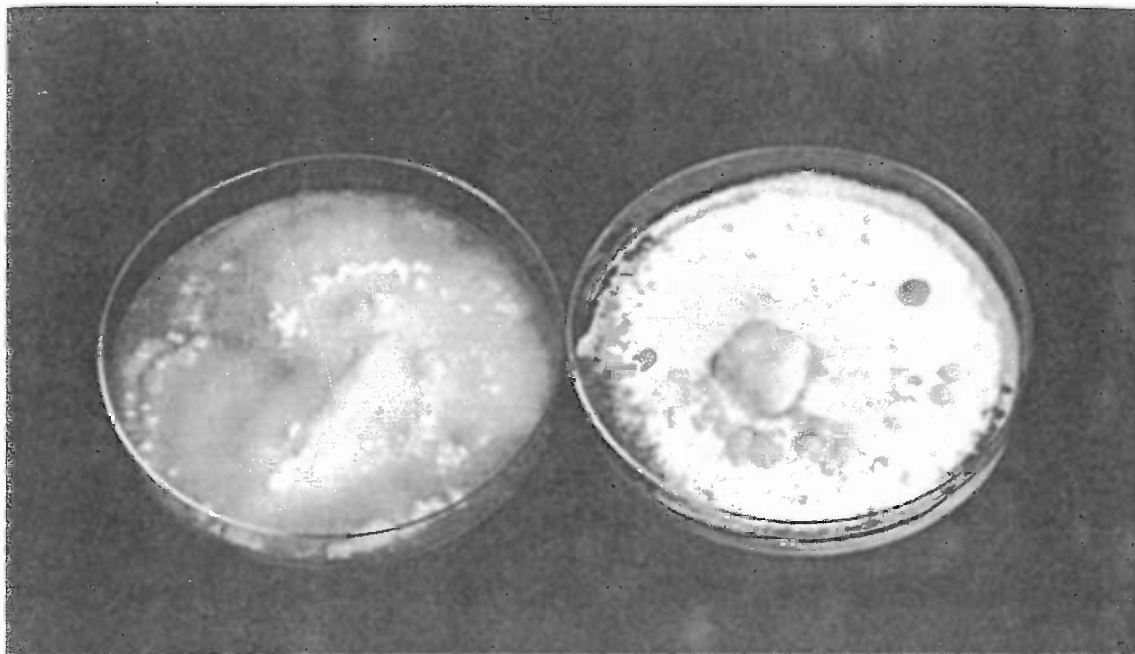

Figure 91. Hyphal aggregates of the Fairy Ring mushroom (*Marasmius oreades*) and Shiitake (*Lentinula edodes*).

exemplified by *Laetiporus sulphureus* (*Polyporus sulphureus*), a.k.a. Chicken of the Woods. The mycelium breaks apart with the least disturbance. In front of a laminar flow bench, the sterile wind can cause chains of mycelium (*hyphae*) to become airborne. Free-flying hyphae can cause considerable cross-contamination problems within the laboratory.

7. *Unique Formations*: Upon the surface of the mycelial mat, unique formations occur which can be distinguished from the background mycelium. They are various in forms. Common forms are *hyphal aggregates*, cottony ball-like or shelf-like structures. I view hyphal aggregates as favorable formations when selecting out rapidly fruiting strains of Shiitake. Hyphal aggregates often evolve into primordia, the youngest visible stages of mushroom formation. *Marasmius oreades*, the Fairy Ring

Mushroom, produces shelf-like forms that define the character of its mycelium. *Stropharia rugoso-annulata*, the King Stropharia, has uniquely flattened, plate-like zones of dense and light growth, upon which hyphal aggregates often form. Morel mycelium produces dense, spherical formations called *sclerotia*. These sclerotia can be brightly colored, and abundant, as is typical of many strains of *Morchella angusticeps*, or dull colored, and spars, like those of *Morchella esculenta* and *Morchella crassipes*.

The mycelia of some mushrooms generate asexual structures called coremia (broom-like bundles of spores) which resemble many of the black mold contaminants. Some of these peculiar formations typify *Pleurotus cystidiosus*, *Pleurotus abalonus*, and *Pleurotus smithii*. I know of one Ph.D. mycologist who, not knowing that some Oyster mushrooms go through an

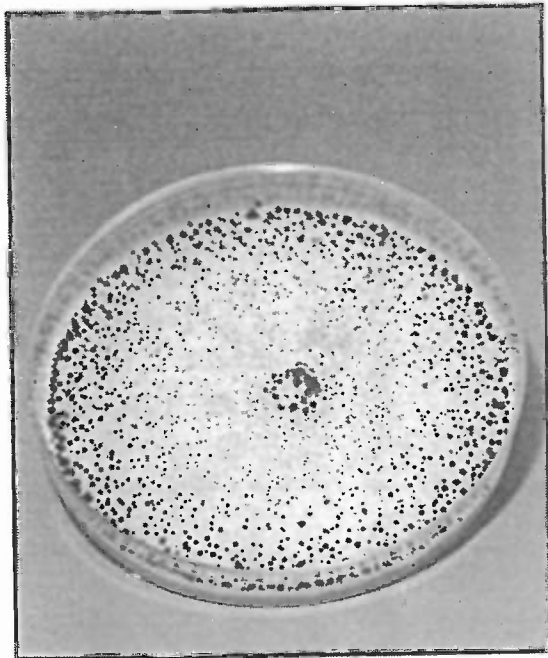

Figure 92. A strain of the Abalone Oyster Mushroom, *Pleurotus cystidiosus*. This mushroom species is dimorphic—having an alternative life cycle path (see Figure 41). The black droplets are resplendent with spores and are *not* contaminants.

asexual stage, promptly discarded the cultures I gave her because they were “contaminated”. (See Figure 92.)

Mushroom strains, once characterized by rhizomorphic mycelia, often degenerate after many transfers. Usually the decline in vigor follows this pattern: A healthy strain is first rhizomorphic in appearance, and then after months of transfers the culture *sectors*, forming diverging “fans” of linear, cottony and appressed mycelium. Often an unstable strain develops mycelium with aerial tufts of cotton-like growth. The mycelium at the center of the petri dish, giving birth to these fans of disparate growth, is genetically unstable, and being in an active state of decline, sends forth mutation-ridden chains of cells. Often times, the

ability to give rise to volunteer primordia on nutrified agar media, once characteristic of a strain, declines or disappears entirely. Speed of growth decelerates. If not entirely dying out, the strain is reduced to an anemic state of slow growth, eventually incapable of fruiting. Prone to disease attack, especially by parasitic bacteria, the mushroom strain usually dies.

**Color:** Most mushroom species produce mycelia that undergo mesmerizing transformations in pigmentation as they age, from the youngest stages of growth to the oldest. One must learn the natural progression of colorations for each species’ mycelium. Since the cultivator is ever watchful for the occurrence of certain colors which can forebode contamination, knowing these changes is critical. Universally, the color green is bad in mushroom culture, usually indicating the presence of

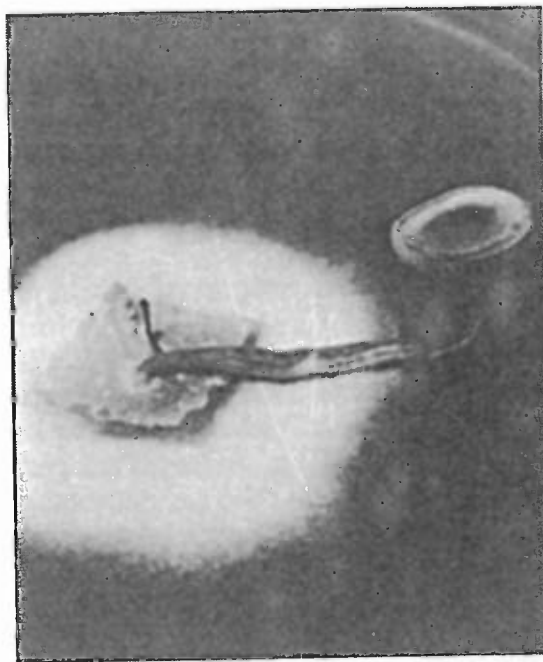

Figure 93. Miniature mushroom (*Gymnopilus luteofolius*) forming on malt agar media. Note proportion of mushroom relative to mycelial mat.



molds belonging to *Penicillium*, *Aspergillus* or *Trichoderma*.

1. White: The color shared by the largest population of saprophytic mushrooms is white. Oyster (*Pleurotus* spp.), Shiitake (*Lentinula edodes*), Hen-of-the-Woods (*Grifola frondosa*), the King Stropharia (*Stropharia rugoso-annulata*) and most Magic Mushrooms (Psilocybes) all have whitish colored mycelium. Some imperfect fungi, like *Monilia*, however, also produce a whitish mycelium. (See *The Mushroom Cultivator*, Stamets and Chilton 1983.)

2. Yellow/Orange/Pink: Nameko (*Pholiota nameko*) produces a white mycelial mat which soon yellows. Oyster mushrooms, particularly *Pleurotus ostreatus*, exude a yellowish to orangish metabolite over time. These metabolites are sometimes seen as droplets on the surface of the mycelium or as excessive liquid collecting at the bottom of the spawn containers. Strains of Reishi, *Ganoderma lucidum*, vary considerably in their appearance, most often projecting a white mycelium which, as it matures, becomes yellow as the agar medium is colonized. A pink Oyster mushroom, *Pleurotus djamor*, and Lion's Mane, *Hericium erinaceus*, both have mycelium that is initially white and, as the cultures age, develop strong pinkish tones. Chicken-of-the-woods (*Polyporus* or *Laetiporus sulphureus*) has an overall orangish mycelium. Kuritake (*Hypholoma sublateritium*) has mycelium that is white at first and in age can become dingy yellow-brown.

3. Brown: Some mushroom species, especially Shiitake, becomes brown over time. It would be abnormal for Shiitake mycelium *not* to brown in age or when damaged. Similarly, *Agrocybe aegerita* produces an initially white mycelium that browns with maturity. Morel mycelium is typically brown after a week of growth.

4. Blue: *Lepista nuda*, the Wood Blewit, pro-

duces a blue, cottony mycelium. Many species not yet cultivated are likely to produce blue mycelia. Although the number of species generating blue mycelium is few, most of the psilocybian mushrooms are characterized by mycelium which bruises bluish when damaged. Beyond these examples, blue tones are highly unusual and warrant examination through a microscope to ascertain the absence of competitor organisms, particularly the blue-green *Penicillium* molds. Although unusual, I have seen cultures of an Oyster mushroom, *P. ostreatus* var. *columbinus*, which produces whitish mycelium streaked with bluish tones.

5. Black: Few mushrooms produce black mycelium. Some Morel strains cause the malt extract medium to blacken, especially when the petri dish culture is viewed from underneath. The parasitic Honey Mushroom, *Armillaria mellea*, forms uniquely black rhizomorphs. A pan-tropical Oyster mushroom, called *Pleurotus cystidiosus*, and its close relatives *P. abalonus* and *P. smithii*, have white mycelia that become speckled with black droplets. (See Figure 92.)

6. Multicolored: Mycelia can be zonate, with multicolored tones in concentric circles around the zone of transfer. The concentric circles of growth are usually diurnal, reflecting rates of growth dictated by the passage of day to night. All of the species described in the past 5 categories undergo unique color changes. This sequence of color transformation defines the unique "personality" of each strain. I have yet to see a mycelium of greater beauty than that of the extraordinary *Psilocybe mexicana*, the sacramental Teonanacatl of Mexico. Its mycelium is initially white, then yellow, golden, brown and sometimes streaked through with bluish tones. (See Color Plate 2, opposite page 176 in *The Mushroom Cultivator* by Stamets and

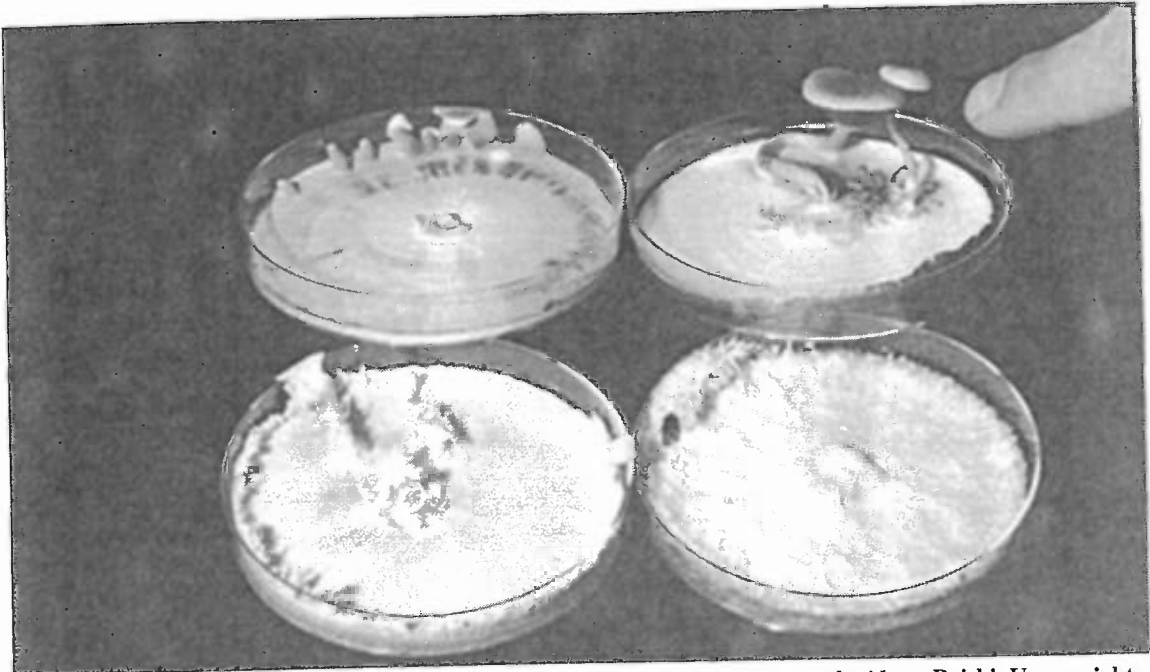

Figure 94. Mushroom primordia on malt agar media. Upper left: *Ganoderma lucidum*, Reishi. Upper right: *Agrocybe aegerita*, the Black Poplar Mushroom. Lower left: *Pleurotus djamor*, the Pink Oyster Complex. Lower right: *Hericium erinaceus*, the Lion's Mane mushroom.

Chilton, 1983.)

**Fragrance:** The sensation most difficult to describe and yet so indispensable to the experienced spawn producer is that of fragrance. The mycelium of each species out-gasses volatile wastes as it decomposes a substrate, whether that substrate is nutrified agar media, grain, straw, sawdust, or compost. The complexity of these odors can be differentiated by the human olfactory senses. In fact, each species can be known by a *fragrance signature*. As the mass of mycelium is increased, these odors become more pronounced. Although odor is generally not detectable at the petri dish culture, it is distinctly noticed when a red-hot scalpel blade touches living mycelium. The sudden burst of burned mycelium emits a fragrance that is specific to each species. More useful to cultivators is the fragrance signature emanating

from grain spawn. Odors can constantly be used to check spawn quality and even species identification.

On rye grain, Oyster mycelium emits a sweet, pleasant, and slightly anise odor. Shiitake mycelium has an odor reminiscent of fresh, crushed Shiitake mushrooms. Chicken-of-the-Woods (*Laetiporus (Polyporus) sulphureus*) is most unusual in its fragrance signature: grain spawn has the distinct scent of butterscotch combined with a hint of maple syrup! King Stropharia (*Stropharia rugoso-annulata*) has a musty, phenolic smell on grain but a rich, appealing woody odor on sawdust. Maitake (*Grifola frondosa*) mycelium on grain reminds me of day-old, cold corn tortillas! Worse of all is Enokitake—it smells like week-old dirty socks. Mycologists have long been amazed by the fact that certain mushrooms pro-

duce odors which humans can recognize elsewhere in our life experiences. Some mushrooms smell like radishes, some like apricots, and even some like bubble gum! Is there any significance to these odors? Or is it just a fluke of nature?

## The Event of Volunteer Primordia on Nutrified Agar Media

The voluntary and spontaneous formation of miniature mushrooms in a petri dish is a delightful experience for all cultivators. In this chapter, attention and insights are given for many species. By no means is this knowledge static. Every cultivator contributes to the body of knowledge each time a mushroom is cultured and studied.

The cultivator plays an active role in developing strains by physically selecting those which look "good". Integral to the success of the Mushroom Life Cycle is the mycelial path leading to primordia formation. To this end, the mushroom and the cultivator share common interests. The occurrence of primordia not only is a welcome affirmation of the strain's identity but is also indicative of its readiness to fruit. Hence, I tend to favor strains which voluntarily form primordia.

Two approaches lead to primordia formation from cultured mycelium. The first is to devise a standard media, a background against which all strains and species can be compared. After performance standards are ascertained, the second approach is to alter the media, specifically

improving and designing its composition for the species selected. As a group, those strains needing bacteria to fruit do not form primordia on sterile media.

Several mushroom species have mycelial networks which, when they are disturbed at primordia formation, result in a quantum leap in the vigor of growth and in the number of subsequently forming primordia. With most strains however, the damaged primordia revert to vegetative growth. The following list of species are those that produce volunteer primordia on 2% enriched malt extract agar, supplemented with .2% yeast and .005% gentamycin sulfate. \*The formation of primordia on this medium is often strain specific. Those species in bold lettering are known by this author to benefit from the timely disturbance of primordia. Those which do benefit from disturbance are excellent candidates for liquid inoculation techniques.

*Agrocybe aegerita*  
***Flammulina velutipes***  
*Ganoderma lucidum*  
***Hericium erinaceus***  
***Hypsizygus tessulatus***  
***Hypsizygus ulmarius***  
*Lentinula edodes*  
*Pholiota nameko*  
*Pleurotus citrinopileatus*  
***Pleurotus djamor*** complex  
***Pleurotus euosmus***  
***Pleurotus ostreatus***  
***Pleurotus djamor***  
***Pleurotus pulmonarius***

\* 1/20 of a gram of gentamycin sulfate per liter of media sufficiently inhibits bacteria to a containable level.



# Evaluating a Mushroom Strain

**W**hen a mushroom is brought into culture from the wild, little is known about its performance until trials are conducted. Each mushroom strain is unique. Most saprophytic fungi, especially primary saprophytes, are easy to isolate from nature. Whether or not they can be grown under “artificial” conditions, however, remains to be seen. Only after the cultivator has worked with a strain, through all the stages of the culturing process, does a recognizable pattern of characteristics evolve. Even within the same species, mushroom strains vary to surprising degrees.

A cultivator develops an intimate, co-dependent relationship with every mushroom strain. The features listed below represent a mosaic of characteristics, helping a cultivator define the unique nature of any culture. By observing a culture’s daily transformations, a complex field of features emerges, expressing the idiosyncrasies of each strain. Since tons of mushrooms are generated from a few petri dish cultures in a matter of weeks, these and other factors play essential roles in the success of each production run.



Once familiar with a particular culture, variations from the norm alert the cultivator to possible genetic decline or mutation. When differences in expression occur, not attributable to environmental factors such as habitat (substrate) or air quality, the cultivator should be alarmed. One of the first features in the tell-tale decline of a strain is "mushroom aborts". Aborting mushrooms represent failures in the mushroom colony, as a singular organism, to sustain total yield of all of its members to full maturity. The next classic symptom witnessed with a failing strain is the decline in the population of primordia. Fewer and fewer primordia appear. Those which do form are often dwarfs with deformed caps. These are just some of the features to be wary of should your strain not perform to proven standards.

A good strain is easy to keep, and difficult or impossible to regain once it senesces. *Do not underestimate the importance of stock cultures.* And do not underestimate the mutability of a mushroom strain once it has been developed. I use the following check-list of 28 features for evaluating and developing a mushroom strain. Most of these features can be observed with the naked eye.

## 28 Features for Evaluating and Selecting a Mushroom Strain

The strain of mushroom, its unique personality—mannerisms, sensitivities, yield expressions—is the foundation of any mushroom farm. When a strain goes bad, production precipitously declines, typically followed by a proliferation of disease organisms. Therefore, cultivators must continuously scrutinize new strains to find candidates worthy of production. Once a strain has been



Figure 95. Grain spawn 3 days and 8 days after inoculation. Visible recovery of spawn two days after inoculation is considered good, one day is considered excellent.

developed, multiple back-ups are made in the form of test tube slants. Test tube slants insure long term storage for future use. The cold storage of test tube slants limits the rate of cell divisions, protecting the strain from mutation and senescence factors.

Although this list is not all inclusive, and can be expanded by any knowledgeable cultivator, it reveals much about the goals cultivators ultimately seek in bringing a strain into culture. However, the following list arises from a uniquely human, self-serving perspective: creating food for human consumption. From an ecological perspective, this list would be considerably altered.

**1. Recovery** The time for a mushroom strain to recover from the concussion of inocu-



Figure 96. Healthy mushroom mycelium running through cardboard.

lation. This is often referred to as “leap off.” Oyster and Morel strains are renowned for their quick “leap off” after transfer, evident in as short as 24 hours. Some strains of mushrooms show poor recovery. These strains are difficult to grow commercially unless they are re-invigorated through strain development and/or media improvement.

**2. Rate of growth** Strains differ substantially in their rate of growth at all stages of the mushroom growing process. Once the mycelium recovers from the concussion of inoculation, the pace of cell divisions quickens. Actively growing mycelium achieves a *mycelial momentum*, which, if properly managed, can greatly shorten the colonization phase, and ultimately the production cycle.

The fastest of the species described in this book has to be the Morels. Their mycelia typically covers a standard 100 x 15 mm. petri dish

in 3-5 days at 75° F. (24° C.). Oyster strains, under the same conditions typically take 5-10 days depending on the size of the transfer and other factors. All other conditions being the same (i. e. rate of inoculation, substrate, incubation environment) strains taking more than 3 weeks to colonize nutrified agar media, grain, or bulk substrates are susceptible to contamination. With many strains, such as Oyster and Shiitake, a sufficient body of knowledge and experience has accumulated to allow valid comparisons. With strains relatively new to mushroom science, benchmarks must first be established.

**3. Quality of the Mycelial Mat** Under ideal conditions, the mycelial mat expands and thickens with numerous hyphal branches. The same mycelium under less than perfect conditions, casts a mycelial mat finer and less dense. Its “hold” on the substrate is loose. In this case, the substrate, although fully colonized, falls apart with ease. In contrast, a mycelium properly matched with its substrate forms a mat tenacious in character. The substrate and the mycelium unify together, requiring considerable strength to rip the two apart. This is especially true of colonies of Oyster, King Stropharia and *Psilocybe* mushrooms.

Some species of mushrooms, by nature, form weak mycelial mats. This is especially true of the initially fine mycelium of Morels. *Pholiota nameko*, the slimy Nameko mushroom, generates a mycelium considerably less tenacious than *Lentinula edodes*, the Shiitake mushroom, on the same substrate and at the same rate of inoculation. Once a cultivator recognizes each species’ capacity for forming a mycelial network, recognizing what is a “strong” or “weak” mycelium becomes obvious.

**4. Adaptability to single component, formulated and complex substrates** Some strains are well known for their adaptability to a va-

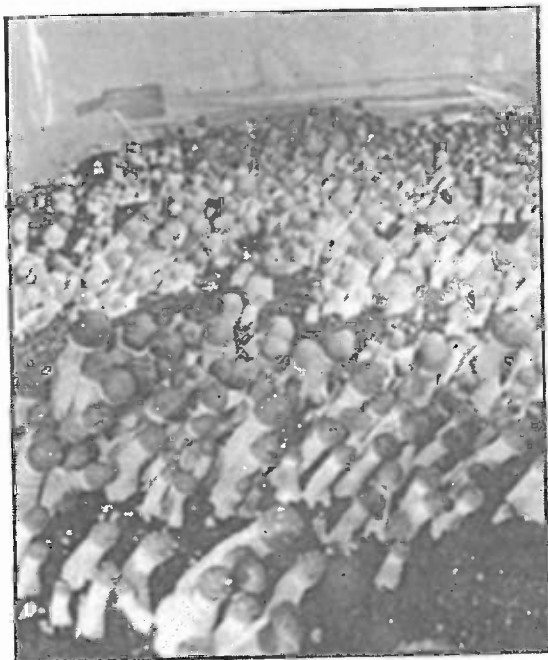

Figure 97. Phototropic response of *Psilocybe cubensis* to light.

riety of substrates. Oyster and King Stropharia are good examples. Oyster mushrooms, native to woodlands, can be grown on cereal straws, corn stalks, sugar cane bagasse, coffee leaves, and paper (including a multitude of paper by-products). These species' ability to utilize such a spectrum of materials and produce mushrooms is nothing short of amazing. Although most strains can grow vegetatively on a wide assortment of substrates, many are narrowly specific in their substrate requirements for mushroom production.

**5. Speed of colonization to fruiting** Here, strains can fall into two sub-categories. One group produces mushrooms directly after colonization. This group includes the Oyster mushrooms (*Pleurotus pulmonarius*, some warm weather *P. ostreatus* strains), Lion's Manes (*Hericium erinaceus*) and the Paddy

Straw (*Volvariella volvacea*) mushrooms. Others, like the Woodlovers (*Hypholoma capnoides* and *H. sublateritium*) require a sustained resting period after colonization, sometimes taking up to several weeks or months before the onset of fruiting.

**6. Microflora Dependability/Sensitivity** Some gourmet and medicinal mushroom species require a living community of microorganisms. The absence of critical microflora prevents the mycelium from producing a fruitbody. Hence, these species will not produce on sterilized substrates unless microflora are introduced. The King Stropharia (*Stropharia rugoso-annulata*), Zhu Ling (*Polyporus umbellatus*), and the Button Mushroom (*Agaricus brunnescens*) are three examples. Typically, these species benefit from the application of a microbially enriched soil or "casing" layer.

The Blewitt, *Lepista nuda*, has been suggested by other authors as being a microbially dependent species. However, I have successfully cultivated this mushroom on sterilized sawdust apart from any contact with soil microorganisms. The Blewitt may fall into an intermediate category whose members may not be absolutely dependent on microflora for mushroom production, but are quick to fruit when paired with them.

**7. Photosensitivity** The sensitivity of mushrooms to light is surprising to most who have heard that mushrooms like to grow in the dark. In fact, most of the gourmet and medicinal mushrooms require, and favorably react to, light. The development of mushrooms is affected by light in two ways. Initially, primordia form when exposed to light. Even though thousands of primordia can form in response to brief light exposure, these primordia will not develop into normal looking mushrooms unless light is



sustained. Without secondary exposure to light *post primordia formation*, Oyster mushrooms, in particular, malform. Their stems elongate and the caps remain undeveloped. This response is similar to that seen in high CO<sub>2</sub> environments. In both cases, long stems are produced. This response makes sense if one considers that mushrooms must be elevated above ground for the caps and subsequently forming spores to be released. Oyster, Shiitake and Reishi all demonstrate strong photosensitivity.

**8. Requirement for cold shock** The classic initiation strategy for most mushrooms calls for drastically dropping the temperature for several days. With many temperate mushroom strains, the core temperature of the substrate must be dropped below 60-65° F. (15-18° C.) before mushroom primordia will set. Once formed, temperatures can be elevated to the 70-

80° F. (21-27° C.) range. This requirement is particularly critical for strains which have evolved in temperate climates, where distinct seasonal changes from summer to fall precedes the wild mushroom season. Because of their cold shock requirement, growing these strains during the summer months or, for instance, in southern California would not be advisable. Strains isolated from subtropical or tropical climates generally do not require a cold shock. As a rule, warm weather strains grow more quickly, fruiting in half the time than do their cold-weather cousins. Experienced cultivators wisely cycle strains through their facility to best match the prevailing seasons, thus minimizing the expense of heating and cooling.

**9. Requirement for high temperature** Many warm weather strains will not produce at cooler temperatures. Unless air temperature is elevated above the minimum threshold for trig-



Figure 98. Phototropic response of two strains of *Ganoderma lucidum* to light.

gering fruiting, the mycelium remains *in stasis*, what cultivators term "over-vegetation." *Volvariella volvacea*, the Paddy Straw Mushroom, will not produce below 75° F. (24° C.) and in fact, most strains of this species die if temperatures drop below 45° F. (7.2° C.). *Pleurotus pulmonarius*, a rapidly growing Oyster species, thrives between 75-85° F. (24-29° C.) and is not prevented from fruiting until temperatures drop below 45° F. (7° C.). With most temperature-tolerant strains, higher temperatures cause the mushrooms to develop more quickly. Another example is *Pleurotus citrinopileatus*, the Golden Oyster, which fruits when temperatures exceed 65° F. (18° C.).

**10. Number and distribution of primordial sites** For every cultivator, the time before and during primordia formation is one of high anxiety, expectation and hope. The change-over from vegetative colonization to this earliest period of mushroom formation is perhaps the most critical period in the mushroom life cycle. With proper environmental stimulation, the cultivator aids the mushroom organism in its attempt to generate abundant numbers of primordia. Aside from the influences of the environment and the host substrate, a strain's ability to produce primordia is a genetically determined trait. Ideally, a good strain is one that produces a population of numerous, evenly distributed primordia within a short time frame.

**11. Site-specific response to low carbon dioxide levels** As the mycelium digests a substrate, massive amounts of carbon dioxide are produced, stimulating mycelial growth but preventing mushroom formation. The pronounced reaction of mycelium to generate primordia in response to lowering carbon dioxide gives the cultivator a powerful tool in scheduling fruitings. Strains vary in their degree of sensitivity to fluctuations in carbon dioxide.

Mushroom cultivators who grow Oyster mushrooms in plastic columns or bags desire strains that produce primordia exactly where holes have been punched. The holes in the plastic become the ports for the exodus of carbon dioxide. At these sites, the mycelium senses the availability of oxygen, and forms primordia. This response is very much analogous to the mushroom mycelium coming to the surface of soil or wood, away from the CO<sub>2</sub> rich environment from within, to the oxygenated atmosphere of the outdoors, where a mushroom can safely propel spores into the wind currents for dispersal to distant ecological niches. With strains super-sensitive to carbon dioxide levels, the cultivator can take advantage of this site-specific response for controlled cropping, greatly facilitating the harvest.

**12. Number of primordia forming vs. those maturing to an edible size.** Some strains form abundant primordia; others seem impotent. Those which produce numerous primordia can be further evaluated by the percentage of those forming compared to those developing to a harvestable stage. Ideally, 90% of the primordia mature. Poor strains can be described as those which produce primordial populations where 50% or more fail to grow to maturity under ideal conditions. Aborted primordia become sites of contamination by molds, bacteria and even flies.

**13. Number of viable primordia surviving for 2nd and 3rd flushes** Some strains of Oyster and Button mushrooms, especially cold-weather varieties, form the majority of primordia during the first initiation strategy. Many primordia lay dormant, yet viable, for weeks, before development. After the first flush of mushrooms matures and is harvested, the resting primordia develop for the second and subsequent flushes.

**14. Duration between 1st, 2nd and 3rd flushes** An important feature of any mushroom strain is the time between “breaks” or flushes. The shorter the period, the better. Strains characterized by long periods of dormancy between breaks are more susceptible to exploitation by insects and molds. By the third flush a cultivator should have harvested 90% of the potential crop. The sooner these crops can be harvested, the sooner the growing room can be rotated into another crop cycle. The rapid cycling of younger batches poses less risk of contamination.

**15. Spore load factors** Over the years, the white Button mushroom, *Agaricus brunne-cens*, has been genetically selected for small gills, thick flesh, and a short stem. In doing so, a fat mushroom with a thick veil covering short gills emerged, a form that greatly extended shelf life. As a general rule, once spores have been released in mass, the mushroom soon decomposes. Hence, strains that are not heavy spore producers at the time of harvest are attractive to cultivators. Additionally, the massive release of spores, particularly by Oyster mushrooms, is an environmental hazard to workers within the growing rooms and is taxing on equipment. I have seen, on numerous occasions, the spores from Oyster mushrooms actually clog and stop fans running at several hundred rpms, ruining their motors.

Another mushroom notorious for its spore load is Reishi, *Ganoderma lucidum*. Within the growing rooms, a rust-colored spore cloud forms, causing similar, although less severe, allergic reactions to those seen with Oyster mushrooms. Rather than emitting spores for just a few days, as with most fleshy mushrooms, the woody *Ganoderma* generates spores for weeks as it slowly develops.

**16. Appearance: form; size; and color of**

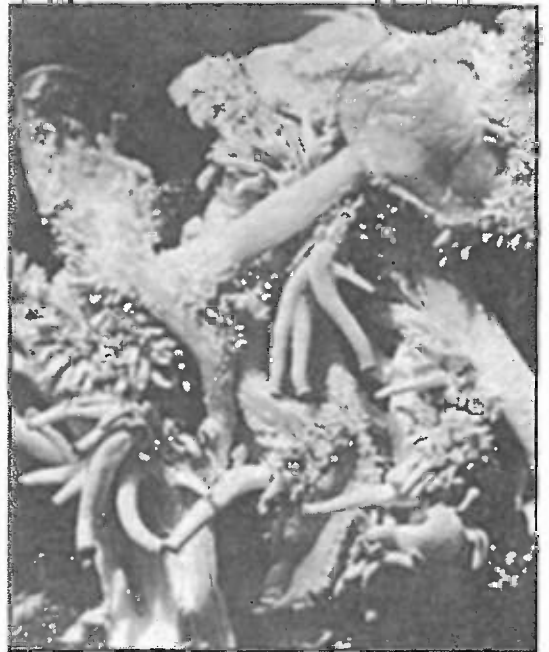

Figure 99. I photographed this unsavory package directly after purchasing it from a major grocery store chain. Mushrooms in this condition, if eaten, cause extreme gastro-intestinal discord. This is the “sajor-caju” variety of *Pleurotus pulmonarius*, also known as the Phoenix Oyster mushroom, and has been a favorite of large scale producers. Subsequent to harvest, hundreds of primordia soon form on the decomposing mushrooms.

**the harvestable mushrooms** Every cultivator has a responsibility to present a quality product to the marketplace. Since gourmet mushrooms are relatively new, national standards have yet to be set in the United States for distinguishing grades. As gourmet mushrooms become more common, the public is becoming increasingly more discriminating.

What a cultivator may lose in yield from picking young mushrooms is offset by many benefits. Young mushrooms are more flavorful, tighter fleshed, often more colorful, and ship and store longer than older ones. Crop rotation, with much less associated spore load, is like-

wise accelerated through the harvest of adolescent forms. Diseases are less likely and consistency of production is better assured.

One general feature is common to all mushrooms in determining the best stage for picking: the cap margin. Cap margins reveal much about future growth. At the youngest stages, the cap margin is incurved, soon becoming decurved, and eventually flattening at maturity. In my opinion, the ideal stage for harvest is midway between incurved and decurved. During this period, spore release is well below peak production. Since the gills are protected by both the curvature of the whole mushroom as well as adorning veil remnants (as in Shiitake), the mushrooms are not nearly as vulnerable to damage. For more information, please consult Chapter 23.

**17. Duration from storage to spoilage:**  
**Preservation** An important aspect of evaluating any strain is its ability to store well. Spoilage is accelerated by bacteria which thrive under high-moisture stagnant air conditions. A delicate balance must be struck between temperature, air movement, and moisture to best prolong the storage of mushrooms.

Some species and strains are more resistant to spoilage than others. Shiitake mushrooms store and ship far better, on the average, than Oyster mushrooms. Some Oyster mushrooms, especially the slow-forming cold weather strains, survive under cold storage longer than the warm weather varieties. In either case, should spores be released and germinate, bacterial infection quickly sets in.

**18. Abatement of growth subsequent to harvest** Yet another feature determining preservation is whether or not the mushrooms stop growing after picking. Many mushrooms continue to enlarge, flatten out, and produce spores long after they have been harvested. This is especially distressing for a cultivator picking a

perfect-looking young specimen one day only to find it transformed into a mature adult the next day. This continued growth often places growers and distant distributors into opposing viewpoints concerning the quality of the product. Strains of *Pleurotus pulmonarius*, especially the so-called "*Pleurotus sajor-caju*" is one such example. I like to describe this strain of Oyster mushrooms as being "biologically-out-of-control." (See Figure 99.)

**19. Necrosis factors and the protection of dead tissue from competitors** After a mushroom has been picked, tissue remnants become sites for attack by predator insects and parasitic molds. Some species, Shiitake for instance, have a woodier stem than cap. When Shiitake is harvested by cutting at the base of the stem, the stem butt, still attached to the wood substrate, browns and hardens. As the stem butt dies, a protective skin forms. This ability to form a tough outer coat of cells protects not only the left-over stem remnant from infestation, but also prevents deep penetration by predators. Since most *Pleurotus ostreatus* strains are not graced with this defense, extreme caution must be observed during harvest so no dead tissue remains. The "sajor-caju" variety of *Pleurotus pulmonarius* is surprising in its ability to reabsorb dead tissue, even forming new mushrooms on the dead body remnants of previously harvested mushrooms.

**20. Genetic stability/instability** Since all strains eventually senesce, genetic stability is of paramount concern to every cultivator. Signs of a strain dying are its inability to colonize a substrate, produce primordia, or develop healthy mushrooms. Typical warning signs are a delay in fruiting schedules and an increasing susceptibility to disease. These symptoms are a few of many which suggest strain senescence.

**21. Flavor** Strains of the same species differ

substantially in flavor. The cultivator needs to be sensitive to customer feedback. Americans favor mildly flavored mushrooms whereas the Japanese are accustomed to more strongly flavored varieties. *Pleurotus citrinopileatus*, the Golden Oyster mushroom, is extremely astringent until thoroughly cooked, a good example that flavor is affected by the length of cooking. Generally speaking, younger mushrooms are better-flavored than older ones. The King Stropharia, *Stropharia rugoso-annulata*, is a good example, being exquisitely edible when young, but quickly losing flavor with maturity. Shiitake, *Lentinula edodes*, has many flavor dimensions. If the cap surface was dry before picking, or cracked as in the so-called "Donko" forms, a richer flavor is imparted during cooking. Although the cracking of the cap skin is environmentally induced, the cultivator can select strains whose cap cuticle easily breaks in response to fluctuating humidity.

**22. Texture** The stage at harvest, the duration and temperature of cooking, and the conditions with which mushrooms are cooked all markedly affect textural qualities. Judging the best combination of texture and flavor is a highly subjective experience, often influenced by cultural traditions. Most connoisseurs prefer mushrooms that are slightly crispy and chewy but not tough. Steamed mushrooms are usually limp, soft and easily break apart, especially if they have been sliced before cooking. By tearing the mushrooms into pieces, rather than cutting, firmness is preserved. These attributes play an important role in the sensual experience of the mycophagist.

**23. Aroma** Few experiences arouse as much interest in eating gourmet mushrooms as their aroma. When Shiitake and Shimeji are stir-fried, the rich aroma causes the olfactory senses to dance, setting the stage for the taste

buds. Once paired with the experience of eating, the aroma signature of each species is a call to arms (or "forks") for mycophagists everywhere. My family begins cooking mushrooms *first* when preparing dinner. The aroma undergoes complex transformations as water is lost and the cells are tenderized. (Please refer to the recipes in Chapter 24.)

**24. Sensitivity to Essential Elements: Minerals and Metals** Gray Leatham (1989) was one of the first researchers to note that nanograms of tin and nickel were critical to successful fruitbody formation in Shiitake. Without these minute amounts of tin and nickel, Shiitake mycelium is incapable of fruiting. Manganese also seems to play a determinate role in the mushroom life cycle. Many other minerals and metals are probably essential to the success of the mushroom life cycle. Since these compounds are abundant in nature, cultivators need not be concerned about their addition to wood-based substrates. Only in the designing of "artificial" wood-free media, does the cultivator run the risk of creating an environment lacking in these essential compounds.

**25. Ability to Surpass Competitors** An essential measure of a strain's performance is its ability to resist competitor fungi, bacteria and insects. Strains can be directly measured by their ability to overwhelm competitor molds, especially *Trichoderma*, a forest green mold, which grows on most woods. On thoroughly sterilized substrates, a mushroom strain may run quickly and without hesitation. Once a competitor is encountered, however, strains vary substantially in their defensive/offensive abilities. Oyster mushrooms (*Pleurotus ostreatus*) for instance, are now recognized for their nematode-trapping abilities. I have even witnessed Sciarid flies, attracted to aromatic Oyster mycelium, alighting too long, and becoming stuck to the aerial mycelium. The degree by which flies

are attracted to a particular Oyster mushroom strain can be considered a genetically determined trait—a feature most cultivators would like to suppress.

**26. Nutritional Composition** Mushrooms are a rich source for amino acids (proteins), minerals and vitamins. The percentages of these compounds can vary between strains. Substrate components contain precursors which can be digested and transformed into tissue to varying degrees by different strains. This may explain why there is such a variation in the protein analysis of, for instance, Oyster mushrooms. The analyses are probably correct. The strains vary in their conversion efficiencies of base substrate components into mushroom flesh.

**27. Production of Primary and Secondary Metabolites** A strain's ability to compete may be directly related to the production of primary and secondary metabolites. All fungi produce extracellular enzymes that break down food sources. Myriads of metabolic by-products are also generated. These extracellular compounds are released through the cell walls of the mycelium, enabling the digestion of potential food sources. Enzymes, such as ligninase which breaks down the structural component in wood, are extremely effective in reducing complex carbon chains, including carbohydrates and hydrocarbons.

Secondary metabolites usually occur well after colonization. A good example is the yellow fluid, the exudate, frequently seen collecting at the bottom of aged spawn containers. *Pleurotus* spp.,

*Stropharia rugoso-annulata*, and *Ganoderma lucidum* are abundant producers of secondary metabolites, especially complex acids and ethylene-related products. These metabolites forestall competition from other fungi and bacteria.

**28. Production of Medicinal Compounds** Bound within the cell walls of mushrooms are chains of heavy molecular weight sugars, polysaccharides. These sugars compose the structural framework of the cell. Many mushroom polysaccharides are new to science and are named for the genus in which they have been first found, such as lentinan (from Shiitake, *Lentinula edodes*), flammulin or "FVP" (from Enokitake, *Flammulina velutipes*), grifolin or grifolan (from Maitake, *Grifola frondosa*), etc. Research in Asia shows that these cell wall components enhance the human immune system. Cellular polysaccharides are more concentrated, obviously, in the compact form of the mushroom than in the loose network of the mycelium. In traditional Chinese pharmacopeia, the sexually producing organ—in this case the mushroom—has long been viewed as a more potent source for medicine than from its infertile representations.

Cell components other than polysaccharides have been proposed to have medicinal effects. Strain selection could just as well focus on their molecular yields. Precursors in the substrate may play determinant roles in the selective production of these components when matched with various strains. (Please refer to Chapter 21.)

## Generating Grain Spawn

**G**rain spawn is the next step in the exponential expansion of mycelial mass. The intent and purpose of grain spawn is to boost the mycelium to a state of vigor where it can be launched into bulk substrates. The grain is not only a vehicle for evenly distributing the mycelium, but also a nutritional supplement. Whole grain is used because each kernel becomes a *mycelial capsule*, a platform from which mycelium can leap into the surrounding expanse. Smaller kernels of grain provide more points of inoculation per pound of spawn. Millet, a small kernel grain, is used by many large spawn producers because end-users like its convenience. Most small scale, gourmet mushroom growers utilize organically grown rye or wheat grain. Virtually all the cereal grains can be used for spawn production. Every spawn maker favors the grain which, from experience, has produced the most satisfactory results.

The preferred rate of inoculation depends upon many factors, not the least of which is cost. If a cultivator buys spawn from a commercial laboratory, the recommended rate is often between 3-7% of substrate mass. What this means is that for every 1000 lbs. of sub-

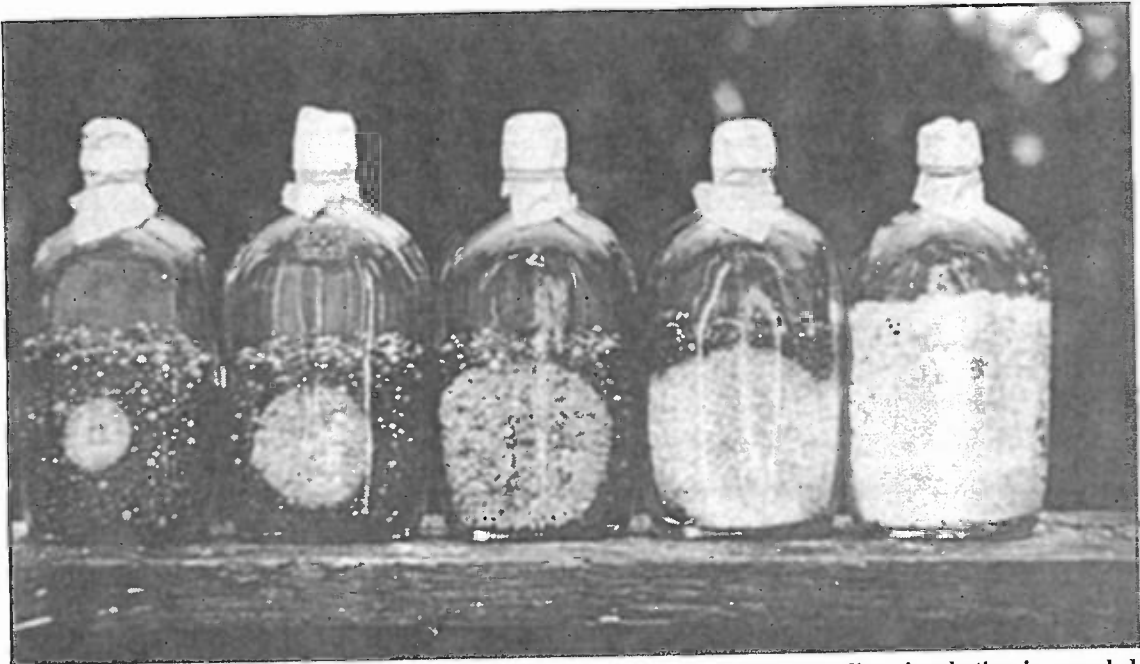

Figure 100. The progressive colonization of sterilized grain by mushroom mycelium incubating in recycled whiskey bottles. This ingenious Thai grower inoculated the centers via a removable tube.

strate (dry weight), 30-70 lbs. of spawn (wet weight) is suggested. Since grain spawn is usually around 50% absolute moisture, this rate of inoculation would be equivalent to 1.5-3.5% of dry spawn/dry substrate.

Cultivators who generate their own spawn frequently use a 8-15% rate of moist spawn/dry substrate, or by this example 80-150 lbs. of fresh spawn per 1000 lbs. This increased rate of spawning accelerates colonization, narrows the window of opportunity for competitor invasion, and boosts yields. Clearly, those making their own spawn have an advantage over those buying spawn from afar.

One major drawback of high spawning rates is increased thermogenesis, the heating up of the substrate as the mycelium overwhelms it. Anticipating and controlling thermogenesis is essential for success. This subject will be explored in detail later on.

VISION  
TECHNOLOGIES

Of the many cereal grains used for creating spawn, rye grain is the most popular. Wheat, milo, sorghum, corn, and millet are also utilized. There are two approaches for preparing grain spawn. The first is to submerge grain in a cauldron of boiling water. After an hour of boiling (or steeping), the saturated grain is drained of water (discarded) and scooped into awaiting spawn containers. Fitted with a lid having a 1/3 to 1/2 in. hole and lined with a microporous filter disc, the grain-filled jars are sterilized in a pressure cooker. This method is widely used and recommended by many because even moisture absorption and consistency is assured.

The second method calls for first placing dry grain into glass spawn jars, adding the recommended amount of water, preferably hot, and allowing the jars to sit overnight. The jars are capped with lids, complete with a 3/8 to 1/2 in. hole and fitted underneath with a microporous



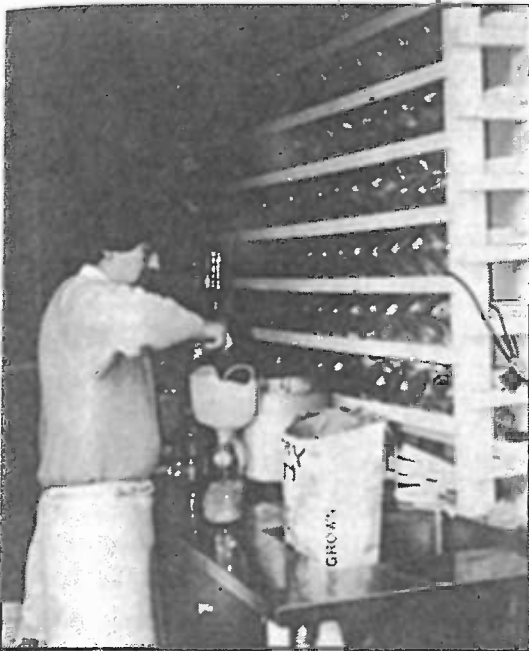

Figure 101. One method for preparing grain spawn is to simply pour dry grain into glass jars, add water, allow to sit overnight, and then sterilize. Advantages of this method are: one-step process; less fuel consumption; and less handling. One disadvantage is uneven water absorption.

filter disc. *By allowing the grain to soak for 12-24 hours, the heat resistant endospores of bacteria germinate and become sensitive to heat sterilization.* Before use, the filter discs should be soaked in a weak (5%) bleach solution to dislodge and disinfect any imbedded contaminants. The next day, the jars are shaken by striking them against a rubber tire, or similar surface, to mix together the more moist and drier grain kernels. Once shaken, they are promptly placed into the sterilizer. The advantage of this method is that it is a one-step procedure. A case can be made that starches and other nutrients are preserved with this method since the water is not discarded. Proponents of the first method argue that not only is their start-

ing material cleaner, but this second technique causes the grains to have an uneven moisture content. The reader must decide which is most suitable. Neither method, in my opinion, merits endorsement over the other.

With excess water, grain kernels explode, exposing the nutrients within, and making them more susceptible to contamination. Exploded grain kernels also cause clumping and sites of depressed gas exchange, environments wherein bacteria proliferate. The shape of the intact grain kernel, with its protective outer surface, selectively favors the filamentous mushroom mycelium and produces a spawn that separates readily upon shaking.

### Suitable Containers for Incubating Grain Spawn:

- 16 fl. oz. mineral spring water bottles,
- quart mason jars, liter bottles
- ½ gallon jars
- 1 gallon jars
- 2 ½ gallon jars
- Polypropylene plastic bags

### Formulas for Creating Grain Spawn

Moisture content plays a critical role in the successful colonization by mushroom mycelium of sterilized grain. If the grain is too dry, growth is retarded, with the mycelium forming fine threads and growing slowly. Should too much water be added to the grain, the grain clumps, and dense, slow growth occurs. Higher moisture contents also encourage bacterial blooms. Without proper moisture content, spawn production is hampered, even though all other techniques may be perfect.

The optimum moisture for grain spawn falls within 45-55%, with an ideal around 50%. To

determine the moisture content of any given formula, weigh 100 grams of the grain, dry it out, and re-weigh the remaining mass. (This can easily be determined by drying out the moistened grain in an oven for at 300° F. (150° C.) for 8 hours. The difference in weight is the water lost, or the percentage moisture.) Now water is added to achieve a targeted moisture content. Once cooked, a sample of grain is taken and oven dried. To check the proposed formula, just take the mass of the lost water divided by the total mass of dried grain *and* the lost water. This will give you a moisture percentage. Remember, moisture percentage is the mass of water divided by total mass, lost water included. This is *not* a ratio of water to dry mass, but a percentage of water over total mass. (This is a common mistake amongst certain schools of Shiitake growers and wood lot managers.) Once a targeted moisture content is achieved, spawn growers rely on volumetric scoops customized to the new formula for ease of handling.

Since grain comes to the consumer with an inherent moisture content of 8-15%, less water is added than might be expected to achieve the right moisture content for spawn production. Each cultivator may want to adjust the following proportions of water to grain to best fit this needs. Keep in mind that one liter (1000 ml.) of water weighs 1 kilogram (1000 g.). A quart is almost a liter and for the purposes of the mushroom cultivator can be used interchangeably. (The amount of grain within each vessel is specified in the following formulas. A variation of only 5-7% between the two volumes is not statistically significant.) Gypsum is added to help keep the kernels separated after sterilization and to provide calcium and sulphur, basic elements promoting mushroom metabolism. (See Stoller, 1962; Leatham and Stahlman, 1989.)

A delicate balance between the mass of grain and added water must be preserved to promote the highest quality spawn. As the spawn container is increased in volume, slightly less water

### Grain Formulas for Spawn Production

#### 16 oz. Mineral Spring Bottles

100 grams rye (approx. 125 ml.)  
150 ml. water  
.5 grams gypsum  
(60% moisture\*)

#### Quart or Liter Jars

200 grams rye  
200 ml. water  
1 gram gypsum  
(50 % moisture\*)

#### 1/2 Gallon or 2 Liter Jars

480 grams rye  
400 ml. water  
2 grams gypsum  
(45 % moisture\*)

#### Gallon or 4 Liter Jars

800 grams rye  
600 ml. water  
4 grams gypsum  
(43% moisture\*)

#### 2 1/2 Gallon 10 Liter Jars

2200 grams rye  
1500 ml. water  
8 grams gypsum  
(40% moisture\*)

#### Standard Spawn Bags (17.5 x 8.25 x 4.75 inches)

3300 grams rye  
1400 ml. water  
12 grams gypsum  
(38% moisture\*)

\* These moisture contents are not meant to be taken literally. The natural moisture content inherent within "dry" grain can affect absolute moisture by 15% or more. Properly dried grain should have 8-12% ambient moisture. With the slightest increase above this level, bacteria proliferate, requiring that the sterilization cycle be extended.

is added proportionately. Whereas the percentage of moisture content can be nearly 60% in a small spawn jar, a large container will have a moisture content of only 40%. Anaerobic environments are encouraged with larger masses of grain, a phenomenon which necessitates a drier medium and extended exposure to pressurized steam. Cultivators should adjust these base-line formulas to best meet their specific circumstances. Jars and bags must be fitted with microporous filters for adequate gas exchange.

I sterilize the 16 oz. or quart (liter) jars for only 1 hour at 15 psi or 250° F, the 1/2 gallons for 1 1/2 hours, the gallon jars for 2 hours, and the standard spawn bags for 4 hours. The spawn bags featured in this book have a maximum volume of 12,530 milliliters when filled to the brim, although cultivators usually load the spawn bags to 1/3 to 1/2 half capacity. Using the

aforementioned formula, each spawn bag weighs 10 lbs., 10 oz. (=4826 grams). These bags are best inoculated with 200-300 ml. of fermented liquid mushroom mycelium using the techniques described further on. Once inoculated the bags are laid horizontally for the first week and gently agitated every 3 days with the filter patch topside, until fully colonized. Spawn generated in bags is far easier to use than from jars.

For a comparison of grains, their moisture contents, and kernels sizes, refer to pg. 43 in *The Mushroom Cultivator* by Stamets and Chilton (1983). Test batches should be run prior to commercial-scale cycles with sterilization indicator papers. Adjustments in pressure must be made for those more than 3000 feet above sea level.

Most people create volumetric scoops corresponding to the above mentioned masses. Many

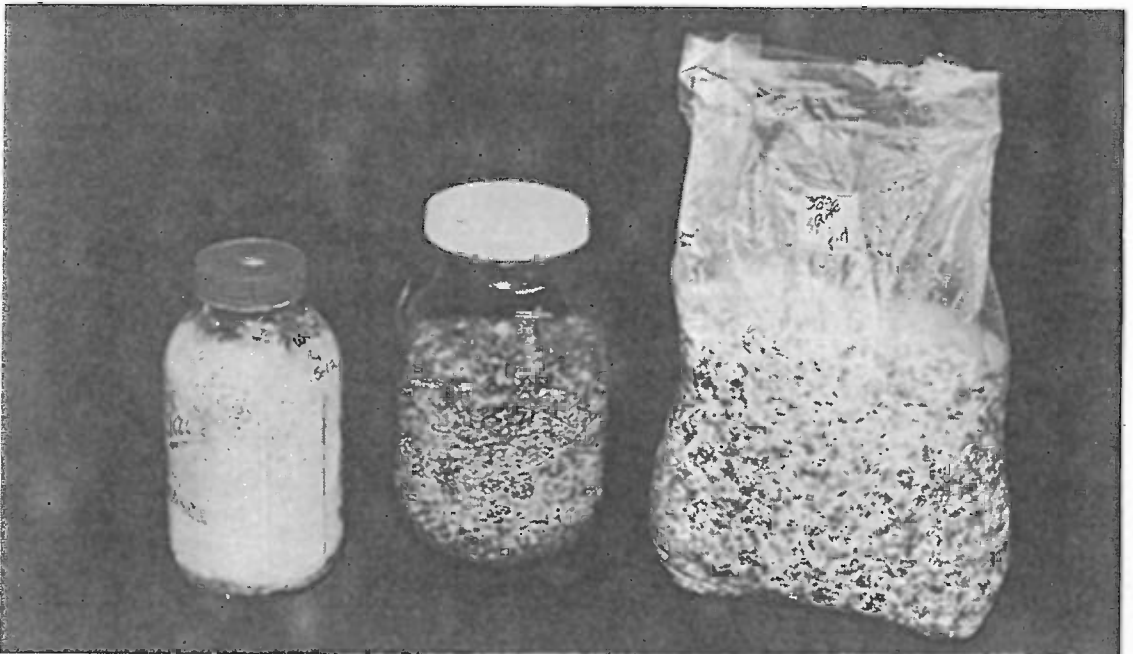

Figure 102. Spawn incubating in 1/2 gallon (2 liter), 1 gallon (4 liter) and 2.5 gallon (10 liter) containers. Note filter media which prevents contamination but allows respiration.



Figure 103. Filling 1/2gallon jars with grain.

cultivators build semi-automatic grain dispenser bins to facilitate the rapid filling of spawn containers. These are similar in design to those seen in many organic food co-ops in North America.

The grain used for spawn production must be free of fungicides and ideally should be organically grown. Grain obtained in the spring was probably harvested 6 or more months earlier. The resident contamination population gradually increases over time. With the proliferation of more contaminants per lb. of grain, cultivators will have to adjust their sterilization schedules to compensate. Experienced cultivators are constantly searching for sources of fresh, high quality grain with endemically low counts of bacteria and mold spores.

With one brand of commercially available rye grain, a cup of dry grain has a mass of 210



Figure 104. Pressure cookers useful for sterilizing agar and grain media. Note the smaller unit has a built-in heat source. The larger pressure cooker is placed on a stove-top or propane burner. Pressure is regulated by adjusting the heat source.

grams. 4 cups is approximately a liter. Therefore, a single petri dish culture can generate from 1 to 5 liters of spawn, utilizing the traditional wedge transfer technique. These techniques are described next.

## First Generation Grain-Spawn Masters

The first time mushroom mycelium is transferred onto grain, that container of spawn is called a Grain Master, or  $G^1$ . The preferred containers for incubating Grain Masters are traditionally small glass jars or bottles, with narrow mouths to limit contaminant exposure. Since the Grain Master is used to generate 100 to 1000 times its mass, special attention is given to its purity. Otherwise, the slightest amount of contamination is exponentially expanded with each step, not by a factor of 10, but by a factor of thousands! Molds have advantages over



Figure 105. Grain-filled 1/2 gallon jars ready for loading into a commercial autoclave.



Figure 106. Sterilization indicator test strips are placed into a few grain filled jars to test effectiveness of sterilization cycle. Note the letter "K" appears when sterilization has been achieved.

mushrooms in that within two to four days every spore can send up hundreds of microscopic tree-like structures called conidiophores on whose branches are dozens more mold spores. (See *The Mushroom Cultivator* (1983) Chapter 13, pp. 233-317). Mushroom mycelium, on the other hand, typically expands as a linear extension of cells. In a jar holding thousands of kernels of grain, a single kernel of grain contaminated with a mold such as *Penicillium*, surrounded by tens of thousands of kernels impregnated with pure mushroom mycelium makes that entire container of spawn useless for mushroom culture.

A single 100 x 15 mm. petri dish culture can inoculate 4-20 cups of sterilized grain. The traditional transfer method calls for cutting the mushroom mycelium into wedges or squares us-

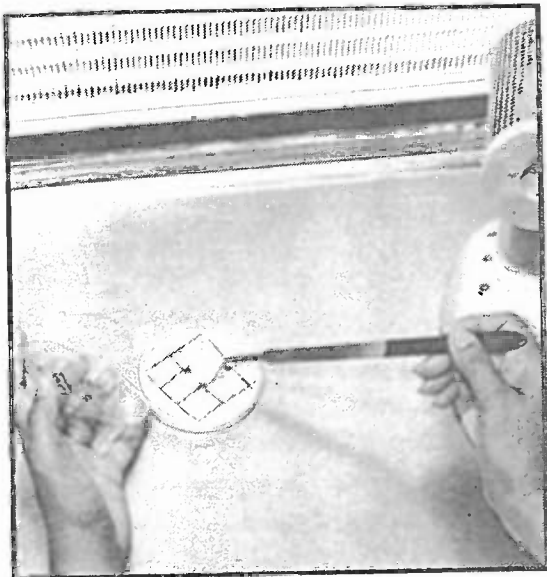

Figure 107. Cutting mycelium from the nutrient agar medium.

ing a sterilized scalpel. Prior to this activity, the space where the transfers are to take place has been aseptically cleaned. The hopeful spawn maker has showered, washed, and adorned newly laundered clothes. Immediately prior to doing any set of inoculations, the cultivator washes his hands and then wipes them with 80% rubbing alcohol (isopropanol). If working in front of a laminar flow hood, the freshest, sterilized material is kept upstream, with the mycelium directly downstream. *The cultivator prioritizes items on the inoculation table by degree and recentness of sterility.* The same attention to movement that was used to inoculate nutrient-filled petri dishes in Chapter 12 is similarly necessary for successful production of grain spawn. Attention to detail, being aware of every minute movement, is again critical to success.

## Steps for Generating Grain Spawn Masters

**Step 1.** Visually ascertain the purity of a

mushroom culture, selecting a petri dish culture showing greatest vigor. Ideally, this culture should be no more than two weeks old, and there should be a margin of uncolonized media along the inside peripheral edge. This uncolonized zone, approximately 1/2 inch (1.30 cm.) in diameter, can tell the cultivator whether or not any viable contaminant spores have recently landed on the media. Once the mycelium has reached the edge of the petri dish, any contaminant spores, should they be present, lie dormant and invisible upon the mushroom mycelium only to wreak havoc later.

**Step 2.** Although the contents within may be sterilized, the outer surface of the pressure cooker is likely to be covered with contaminants which can be transferred via hand contact. Therefore, the outside of the pressure cooker should be thoroughly wiped clean prior to the sterilization cycle. Open the pressure cooker in the laboratory clean room. Ideally, the pressure cooker has formed a vacuum in cooling. If the pressure cooker in use does not form a vacuum, outside air will be sucked in, potentially contaminating the recently sterilized jars. The pressure cooker should be placed in the clean room directly after the sterilization cycle and allowed to cool therein. (I usually place a paper towel saturated with isopropanol over the vent valve as an extra precaution, to filter the air entering the pressure cooker.) Another option is to open the pressure cooker in front of a laminar flow bench at the moment atmospheric pressure is re-achieved. Remove the sterilized grain jars from the pressure cooker. Place the grain-filled jars upstream nearest to the laminar flow filter. Then sterilize the scalpel by flaming until red hot.

**Step 3.** Directly cut into the petri dish culture (The blade cools instantly on contact.) Drag the blade across the mycelium-covered agar, creat-

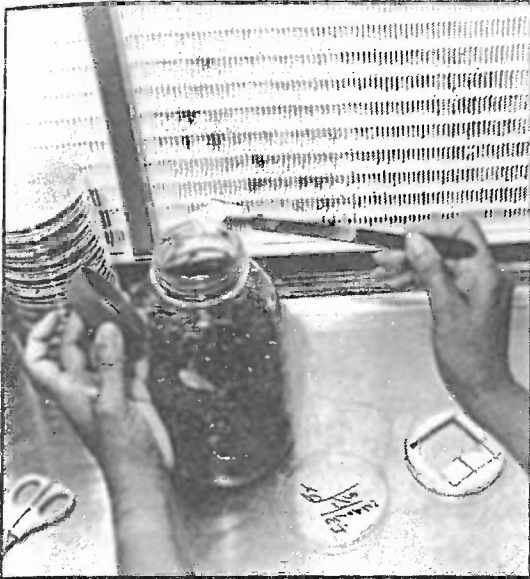

Figure 108. Transferring several squares of mycelium from the nutrified agar medium into sterilized grain.

ing 8 or more wedges. Replace the petri dish lid.

**Step 4.** Loosen the lids of the jars to be inoculated so you can lift them off later with one hand. Re-flame the scalpel. Remove the petri dish cover. Spear two or more wedges simultaneously. Replace the petri dish cover. While moving the wedges of mycelium upstream to the jars, remove the lid of the jar to be inoculated, and thrust the wedges into the sterilized grain. Replace and screw the lid tight. Repeat and shake each jar so the wedges move throughout the interior mass of the grain, with the intention that strands of mycelium will tear off onto the contacted grain kernels.

**Step 5.** Set the inoculated jars of grain onto the shelf and to incubate them undisturbed for several days.

**Step 6.** Three days from inoculation, inspect each jar to determine two preconditions: first, recovery of the mycelium, "leaping off" onto contacted grain kernels and secondly, the absence of any competitor molds, yeasts, mites or bacte-

ria. If these preconditions are satisfied, to the best of your knowledge, continue to the next step.

**Step 7.** Seven days after inoculation, shake each jar again. Ten to fourteen days after inoculation, incubated at 75° F. (24° C.), each jar should be fully colonized with mushroom mycelium. If colonization is not complete three to four weeks after inoculation, something has probably gone awry with the process. Some of the more common causes of slow colonization include unbalanced moisture content, contaminants, weak strain, residual fungicides in the grain, poor quality grain, etc.

Spawn at the peak of cell development is the best to use, correlating to about two weeks after inoculation. The key concept here: *to keep the mycelium running at its maximum potential throughout the spawn generation process.* With over-incubation, the grain kernels become difficult to break apart. It is important for the myceliated grain kernels to separate so they can be evenly dispersed throughout the next generation of substrates. Over-incubation results in clumping and disease.

Grain masters can be kept at room temperature for a maximum of four to eight weeks from the time of original inoculation. Best used within a week of full colonization, some farms refrigerate grain masters until needed. I strongly discourage this practice. The rule here: use it or lose it.

## Second and Third Generation Grain Spawn

The next generation of spawn jars is denoted as G<sup>2</sup>. Each Grain Master can inoculate 5 to 20 times its mass. Many start with narrow mouth quart mason jars for Grain Masters, and use 1/2 gallon or 2 liter jars for Second Generation spawn. (For use of bags as spawn containers, see pg. 138.). Third Generation spawn is typically in



Figure 109. Inoculating G<sup>2</sup> gallon jars of sterilized grain from 1/2 gallon (2 liter) G<sup>1</sup> masters.

bag form and is sold to consumer-growers.

A standard inoculation rate would be 1 quart (liter) Grain Master to five 1/2 gallons, in other words a 1:10 expansion. A diluted inoculation, on the verge of being unsuccessful would be 1 quart Grain Master to twenty 1/2 gallons, in other words a 1:40 expansion. Exceeding a 1:40 expansion of mycelium is likely to be associated with a >20% failure rate, a percentage unacceptable to any spawn laboratory. Not only can the loss be measured in terms of failure to mature, but each failed spawn jar is likely to be center stage for releasing thousands of contaminants back into the laboratory. Liquid inoculation techniques allow a much greater exponent of expansion than the traditional method described here. (See Liquid Inoculation Techniques described on Page 146.)

Step-by-step instructions follow for a classic grain-to-grain inoculation. As before, the

cleanest items should be prioritized nearest to the micron filter. Adherence to sterile inoculation techniques should be strictly observed.

## Steps for Creating Second and Third Generation Grain Spawn

After sterilizing grain in 1/2 gallon or gallon jars, standard procedures for inoculation are followed. For every quart Grain Master, five 1/2 gallon jars are recommended, essentially a 1:10 expansion.

**Step 1.** Select a Grain Master showing even, luxuriant growth. Avoid spawn jars having zones of heavy growth, discoloration, or excess liquid.

**Step 2.** Using a cleaned rubber tire, carefully slam the jar against it, loosening the grain. If the spawn is overgrown, more forcible shaking is required before the spawn kernels will separate. Do not strike the jar against the palm of your



Figure 110. Jars furthest downstream are inoculated first and removed.



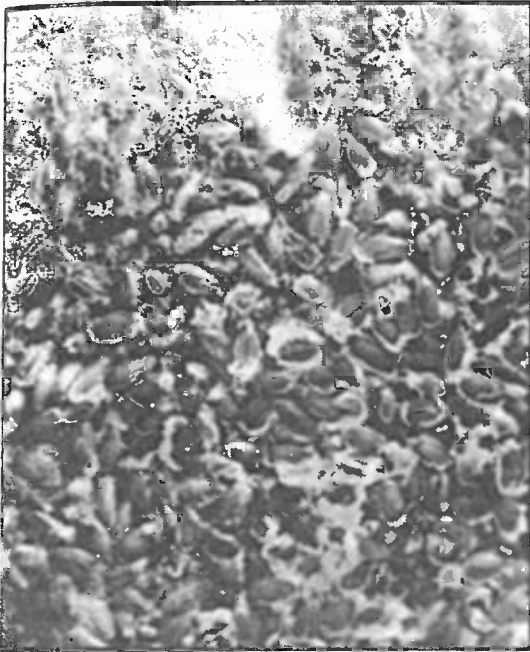

**Figure 111.** Grain inoculated with mycelium but contaminated with bacteria. Note greasy appearance of grain kernels. Bacterially contaminated grain emits a distinct, unpleasant odor.

hand! Be careful! (This author, at the time of this writing, is recovering from a sliced wrist after a brisk visit to the hospital emergency room, caused by a glass jar shattering on his palm during shaking, requiring multiple stitches.)

**Step 3.** Once the Grain Master has been shaken, loosen the lids of the jars which will receive the spawn. Remove the lid of the Grain Master and set it aside. With your favored hand, move the grain master upstream to the first jar, hovering inches above it. With your other hand, remove the lid, and hold it in the air. By tilting downwards and rotating the Grain Master, kernels of spawn fall into the awaiting jar. Replace the lid of the jar just inoculated and continue to the next. By the time the tenth jar is inoculated, the spawn jar should be empty. Repeated transfers eventually lead to an even dispersal of

spawn each time. Precise measurement is desirable but not absolutely critical with this suggested rate of expansion. However, as one becomes more experienced, inoculation rates achieve a high degree of regularity.

**Step 4.** Once inoculated, the lids are tightened securely. Each jar is then shaken to evenly disperse the Grain Master spawn kernels through the sterilized grain. Thorough shaking encourages fast grow-out. As the jars are shaken, note the rotation of the myceliated grain kernels throughout the jar.

**Step 5.** Set the Second Generation Spawn jars upon a shelf or rack in a room maintained at 75° F. (24° C.). The jars should be spaced at least 1/2 inch apart. Closely packed jars self-heat and encourage contamination. I prefer that jars incubate at an incline, allowing for more transpiration.

**Step 6.** After 3-4 days, each jar is shaken again. As before, the grain can be loosened by striking the jars against a rubber tire or similar surface. Grasping each jar firmly, accelerate each jar downwards in a spiral, pulling back at the end of each movement. This technique sends the top grain kernels deep into the bottom recesses of the jar, in effect rotating and mixing the grain mass.

**Step 7.** In 7-10 days, re-inspect each jar to determine even dispersal of growth sites. Should some jars show regions of growth and no-growth, another shaking is in order. Those showing good dispersion need not be disturbed. Here the discretion of the cultivator plays an important role. If any unusual pungent odors are noticed, or if the grain appears greasy, contamination may be present although not yet clearly visible.

**Step 8.** By day 14, all the jars should be thoroughly colonized by mycelium. With Oyster, Shiitake, Enokitake, Reishi, King Stropharia, the mycelium has a grayish-white appearance



Figure 112. 11 lbs. (5 kg.) of grain spawn in 2½ gallon (10-11 liter) glass jar and polypropylene bag. Glass jars are reusable whereas spawn bags are currently not recycled. However, since bag spawn is easier to handle, this is the form most commonly sold to mushroom growers by commercial spawn laboratories.

48 hours before flushing out with bright white mycelium.

Each Second Generation spawn jar can be used for inoculating another set of grain jars, for instance, five-gallon jars containing twice the amount of grain as the 1/2 gallon containers, in effect another 1:10 expansion. (2 1/2 gallon (10 liter) jars or bags can be used at a similar rate. (See Figure 112.)) These would be denoted as G<sup>3</sup>. Third Generation grain spawn is inoculated in exactly the same fashion as Second Generation grain spawn. However, contamination is likely to go unobserved. Some large spawn laboratories successfully generate Fourth Generation spawn. However, contamination outbreaks discourage most from pushing this expansion any further. As the mass of sterilized grain is increased within each larger container, anaerobic conditions can more easily prevail, en-

couraging bacteria. These larger containers require more aeration, a feat that is accomplished with frequent shaking (every 48-72 hours), greater filter surface area, and near-horizontal incubation. When the large containers are laid horizontally, the surface area of the grain-to-air is maximized, providing better respiration for the mushroom mycelium.

Throughout every stage in the grain expansion process, any hint of contamination, *especially smell*, the texture of the grain or unusual colorations, should be considered warning signs. The spawn maker soon develops a sixth sense in choosing which spawn jars should be expanded, and which should be avoided. Most spawn producers only select a portion of the spawn inventory for further propagation. The remainder are designated as "terminal," and are not used for further expansion onto sterilized grain. Un-



Figure 113. Gallon jars of 3rd generation grain spawn incubating.

less contaminated, these terminal spawn jars usually are of sufficient quality for inoculating bulk substrates. Of course, the spawn manager can always exercise the option of using First, Second or Third Generation grain spawn for inoculating sawdust or straw.

In effect, the spawn maker has taken a single petri dish and in three generations of transfers created 250 gallons of spawn. Therefore, a stack of twenty petri dishes can give rise to 5000 gallons of spawn! This places a whole new perspective on the sheer biological power inherent within a single test tube slant, which can easily inoculate a sleeve of 20 petri dishes. Most laboratories do not fully realize the potential of every culture. In many cases, spawn expansion is terminated at  $G^2$ . Many spawn managers choose *not to "chase" the optimum*. Few laboratories are large enough to accommodate the end result of the methods described here.

An alternative method for generating spawn is via Liquid Culture. This method saves time, money, and is less susceptible to contamination. These techniques are described further on.

The next step is for each of these Third Generation spawn units to inoculate ten to twenty its mass in sawdust or straw. See Chapters 16 and 17.

### Autoclavable Spawn Bags

Autoclavable bags have been used by the mushroom industry for nearly 40 years. Primary uses for autoclavable bags are for the incubation of grain and sawdust. Preferences vary widely between cultivators. Flat, non-gusseted bags are popular for incubating grain spawn. The more grain filled into a bag, the greater the danger of poor gas exchange, a major factor leading to contamination. Three-dimensional gusseted bags are used pri-

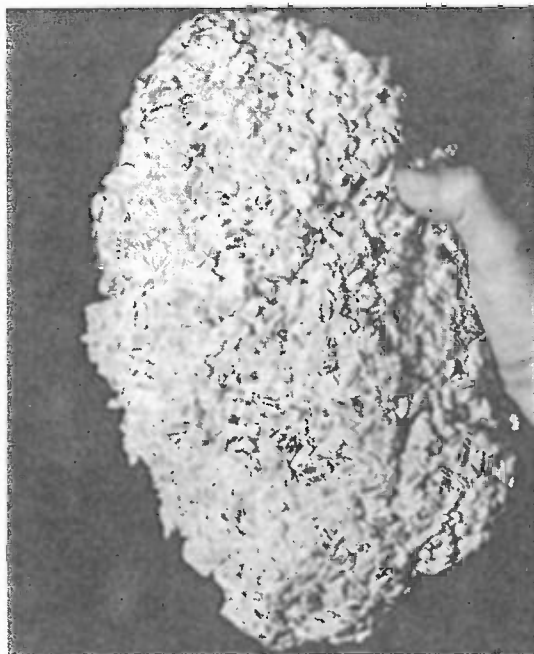

Figure 114. Grain spawn ready for use.

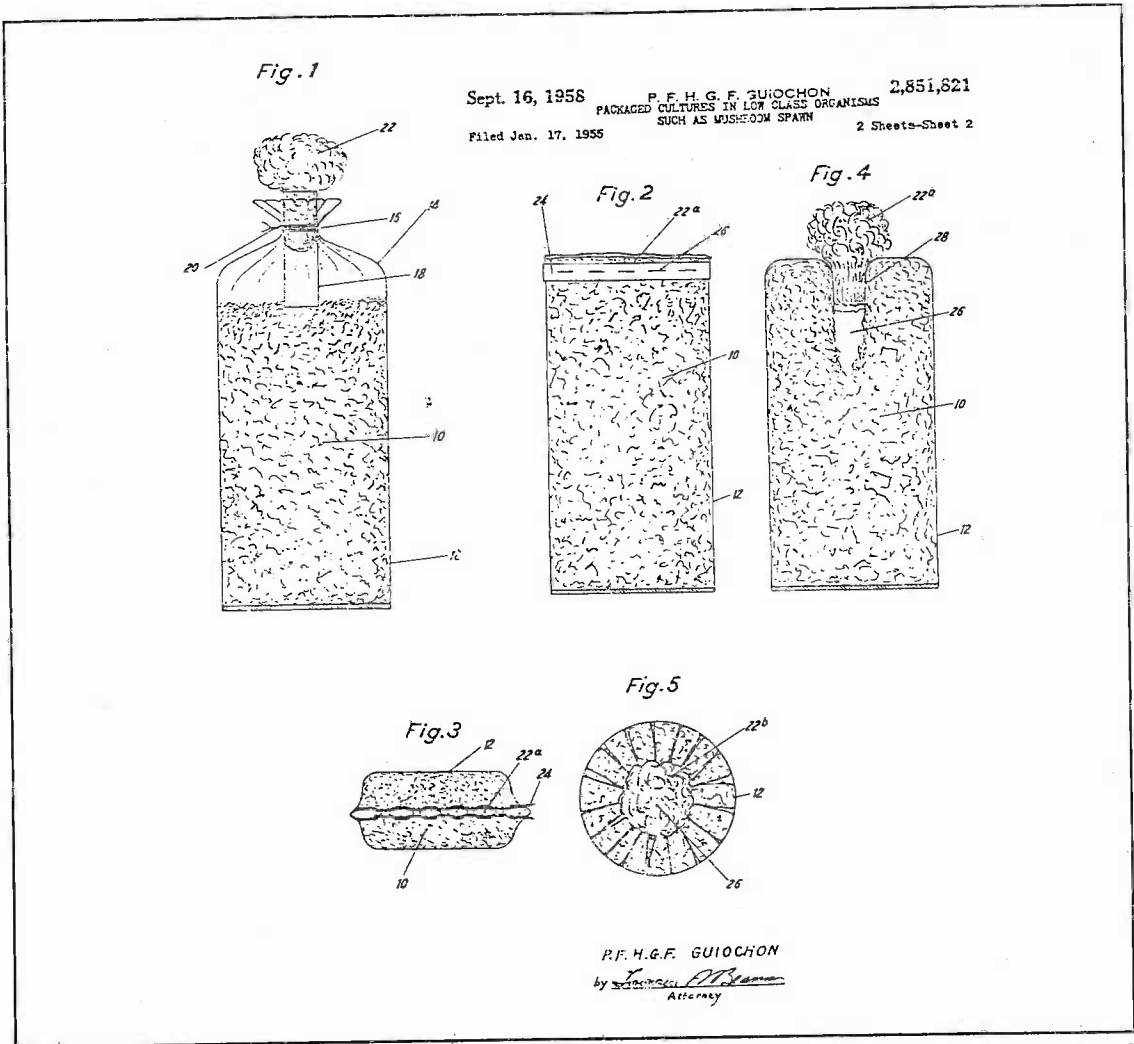

Figure 115. The use of heat tolerant plastic bags greatly advanced the practicality of the bulk processing of grain and sawdust. One of the first patents for this innovation was awarded to Guiochon. (U.S. Patent #2,851,821) in 1958.

marily for holding non-supplemented and supplemented sawdust. The proper handling of these bags is critical to their successful use. Bags contacting hot surfaces become elastic, deform, and fail. Currently the industry uses polypropylene or polymethylpentene bags with and without microporous filters.

Over the years, a number of patents have

been awarded, some long since expired. The use of plastic bags has had a drastic impact on the way many cultivators generate spawn. Numerous patents have been awarded for bags specifically designed for mushroom culture. The earliest patent I can find is from 1958, awarded to a Frenchman by the name of Guiochon (U. S. #2,851,821). His cylindrical

bag resembles those still widely in use by Asian cultivators. (See Figure 115). In 1963 several similar patents were awarded in London (#985,763; 1,366,777 and 1,512,050). R. Kitamura and H. Masubagashi received a patent (#4,311,477) for a specialized mushroom culture bag in 1982. \*

About a dozen bags are currently available to mushroom cultivators, some borrowed from the hospital supply industry. Cellophane deserves re-examination since it is made from wood cellulose and is completely biodegradable. If problems with seam integrity, tensile strength, and heat tolerance could be improved, spawn bags made of this environmentally friendly material could eliminate the widespread use of throw-away plastics. An advantage of cellophane-like materials is that the mushroom mycelium eventually consumes the very bag in which it has been incubated.

Autoclavable bags are inoculated with Grain Masters and are Second or Third Generation. Agar-to-grain inoculation from petri dish cultures to bags is awkward and impractical unless liquid inoculation techniques are employed. (These techniques are fully described later on.) Bags are filled with pre-moistened grain, with the lips folded closed. Some spawn producers use spring-activated clothespins, paper clips, plastic tape, to hold the folds closed. I prefer to simply press the bags together with flaps folded. As the bags are sterilized, the contents exceed the boiling point of water, and gases are released. If the bags are sealed before loading, explosions or "blow-outs"—holes where live steam has vented—are likely.

In the standard 18 x 8 x 5 inch gusseted

autoclavable spawn bag featuring a 1 inch filter patch, no more than 3500 grams of dry grain should be used. \* OneAll-American™ 941 pressure cooker can process 50 lbs. of dry rye grain in one run. However, the pressure cooker—with its tightly packed contents—should be kept at 15+ psi for 4-5 hours to insure even and full sterilization.

If the grain is first boiled or simmered in hot water before filling, even moisture absorption is assured. Excess water collecting at the bottom of the bags often leads to disaster. If this water is re-absorbed back into the media by frequent shaking or by turning the bags so that the excessively moist grain is on top, the cultural environment is soon re-balanced in favor of mycelial growth. Standing water, at any stage in the mushroom cultivation process, encourages competitors. Many spawn producers add 20-30 grams of calcium sulfate to the grain, when dry, to help keep the kernels separated after autoclaving.

After sterilization, 2 hours at 15-18 psi if the bags are separated or 4-5 hours if the bags are tightly packed, the bags are removed and allowed to cool in the pure windstream coming from the laminar flow bench. An alternative is to allow the grain bags to cool within the pressure vessel, provided it is of the type that holds a vacuum. The vacuum is then "broken" by allowing clean-room air to be sucked in. If the pressure cooker does not hold a vacuum, then it should cool within the sterile laboratory to preserve sterility. In either case, I place a pre-sterilized cotton towel, soaked in alcohol, over the vent cock to act as a filter. For equalizing the pressure in a larger autoclave, air passes directly through a microporous filter into the vessel's

\* Other patents, too numerous to list here were also awarded. Many re-designed the seam, the filtration media, and/or sometimes the wording to qualify for a new variation.

\* Please see formulas on page 130. Spawn incubation bags are available from suppliers listed in Appendix IV: Resource Directory.

interior. (See Figure 137.)

Once the bags are cooled, they are unfolded by hand, being careful to only touch the outer surfaces of the plastic. A jar of spawn is selected, shaken and opened. Using a roll-of-the-wrist motion, spawn free-falls into each bag at a recommended rate of 1:10 to 1:40. The bag is then laid down so as to open into the airstream. The top 2 inches of the bag is positioned over the element of a clean heat sealer and expanded open, again by only touching the outer surfaces of the plastic. The clean air coming from the laminar flow filter inflates the bag. I gently press on the sides which further inflates them before sealing. The top arm of the sealer is brought forcibly down, often times two or three times in rapid succession, pausing briefly to allow the plastic seam to re-solidify. Each bag is squeezed to determine whether the seam is complete and to detect leaks. (Often, pin-hole leaks can be detected at this stage. Having a roll of plastic packing tape, 3-4 inches wide, handily solves this problem by simply taping over the puncture site.)

If the bags hold their seal with no leaks, the spawn should be mixed through by shaking each bag. This cultivator strives to capture enough air within each bag so that when they are sealed, each bag appears inflated. Inflated bags are much easier to shake and support better mycelial growth than those without a substantial air plenum. (See Figures 125-129.)

Spawn bags should be set on a shelf, spaced 1/2 inch or more from each other to counter-act heat generation. After four days, each bag should be carefully inspected, laid on a table surface, and rotated to disperse the colonies of mycelium. In another week, a second shake may be necessary to ensure full and even colonization.

The advantages of using bags for processing grain spawn are:

1. In the limited space of a sterilizer, more grain can be treated using bags than jars.

2. Bags, if they break, are not dangerous. Being cut by glass jars is one of the occupational hazards of spawn producers.

3. Since the bags are pliable, spawn can be more easily broken up into individual kernels and distributed into the next substrate. The process of spawning is simply easier.

## Liquid Inoculation Techniques

A rain storm is a form of liquid inoculation. The earliest fungophile, unwittingly or not, used liquid inoculation techniques. Every time mushrooms are eaten, cooked or washed, spores are disseminated in liquid form. Nature's model can be modified for use within the laboratory. Currently several strategies incorporate liquid inoculation methods. The advantages of liquid inoculation are *the speed of colonization, the purity of spawn, and the ease of handling.*

## Spore Mass Inoculation

The ultimate shortcut for culturing mushrooms is via spore mass/liquid inoculation directly into bulk substrates. Primarily used in China, this technique works well with Oyster and Shiitake mushrooms, but is also applicable to all the mushroom species discussed in this book. In effect this process parallels the technology of the brewery industry in the cultivation of yeasts, *Saccharomyces cerevisiae* and allies. Large fermentation vessels are filled with sugar broth, inoculated with pure spores and incubated and aerated via air compressors.

Spore mass inoculation of sterilized substrates is limited to those species which form mushrooms under totally sterile conditions. (Spores collected from wildly picked mushrooms have too many contaminants.) Those

---

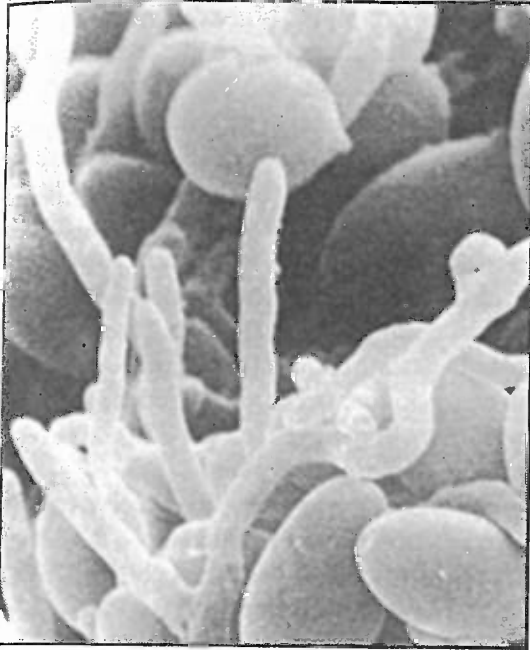

Figure 116. Scanning electron micrograph of spores in a frenzied state of spore germination.

mushrooms that require the presence of microflora, such as the Button Mushroom (*Agaricus brunnescens*) and the King Stropharia (*Stropharia rugoso-annulata*) are excluded. The key requirement is that the parent mushroom fruits on a sterilized substrate, within a sterile environment, and sporulates abundantly. The following mushrooms are some of those which qualify. All are wood or straw saprophytes.

- Agrocybe aegerita*
- Flammulina velutipes*
- Ganoderma lucidum* and allies
- Lentinula edodes*
- Pholiota nameko*
- Pleurotus citrinopileatus*
- Pleurotus djamor*
- Pleurotus eryngii*
- Pleurotus euosmus*

*Pleurotus ostreatus*

*Pleurotus pulmonarius*

A practical approach is to first sterilize a half-filled gallon of wood chips which is then inoculated with grain spawn. After several weeks of incubation, depending on the species, mushrooms form within the environment of the gallon jar. (Supplementation, for instance with rice bran, oatmeal, or rye flour facilitates mushroom formation.) Once mature, the mushrooms are aseptically removed and immersed in sterilized water. Commonly the water is enriched with sugar-based nutrients and trace minerals to encourage rapid spore germination. Millions of spores are washed into the surrounding broth. After vigorous shaking (a few seconds to a few minutes), the spore-enriched liquid is poured off into another sterile container, creating a *Spore-Mass Master*.

Spores begin to germinate within minutes of

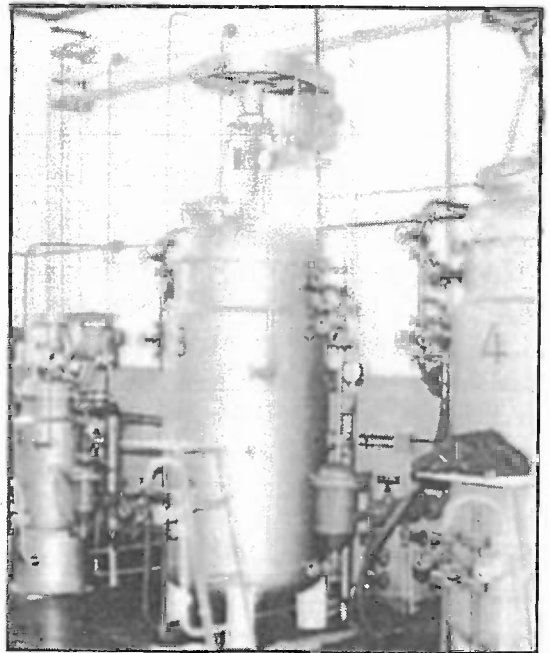

Figure 117. Pressurized vessels in China designed for spore mass fermentation.

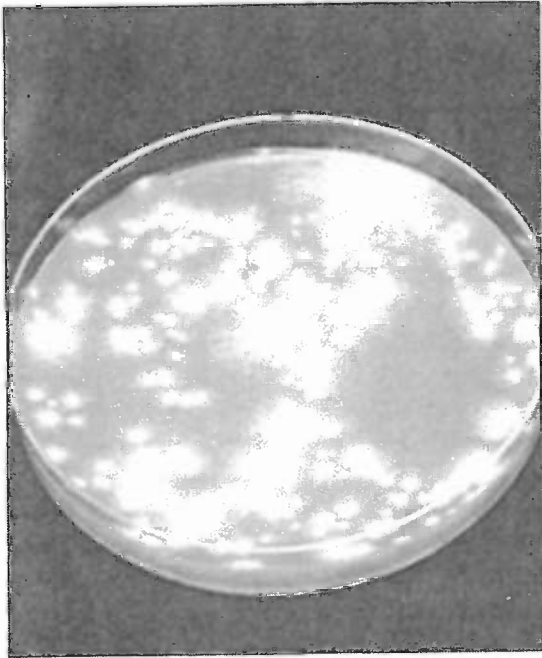

Figure 118. The fermented mycelium is tested for purity by streaking sample droplets across a nutrient media filled petri dish. 48-72 hours later, pure colonies of mycelium (or contaminants) are easily visible.

contact with water. (See Figure 116). Immediately upon germination, and as the mycelium grows, respiration cycles engage. Therefore, the liquid broth must be aerated or the mycelium will be stifled. The method most used by the fermentation industry is aeration via oil-less compressors pushing air through banks of microporous filters. The air is distributed by a submerged aerating stone, a perforated water propellor, or by the turbulence of air bubbles moving upwards, as in a fish aquarium. As the mass of the mycelium increases, and as the filters become clogged with airborne "dust," pressure is correspondingly increased to achieve the same rate of aeration. The vessels must be continuously vented to exhaust volatile metabolites.

Each Spore-Mass Master can inoculate 100 times its mass. For instance, if one removes a Shiitake mushroom, 4-5 inches in diameter, from a jar of sterilized sawdust, and then places that mushroom into a gallon of sterilized water, the spore-enriched broth, the Spore-Mass Master, can inoculate 100 gallons of nutrified liquid media. The functional range of expansion is 1:25 to 1:200, with a heavier inoculation rate always resulting in faster growth. After 2-4 days of fermentation at 75° F. (24° C.), a second stage of expansion can occur into enriched sterilized water, resulting in yet another 25-to 200-fold expansion of mycelial mass.

Success of the fermentation process can be checked periodically by streaking a 1/10th of a milliliter across a sterilized nutrient-filled petri dish and incubating for a few days. (See Figure 118). Additionally, contaminants can be immediately detected through odor and/or through examination of the liquid sample with a microscope. Any gases produced by bacteria or contaminants are easily recognizable, usually emitting uniquely sour or musty and sometimes sickeningly sweet scents.

The liquid spore mass inoculum can be transferred directly onto sterilized substrates such as grain, sawdust, straw, cottonseed hulls, etc. If the liquid inoculum is sprayed, even colonization occurs. If poured, the liquid inoculum streams down through the substrate, following the path of least resistance. Unless this substrate is agitated to distribute the mycelium, colonization will be uneven, resulting in failure.

Theoretically, the germination of spores in mass creates multitudes of strains which will compete with one another for nutrients. This has been long accepted as one of the Ten Commandments of Mushroom Culture. Scientists in China, whose knowledge had not been contaminated by such pre-conceptions, first



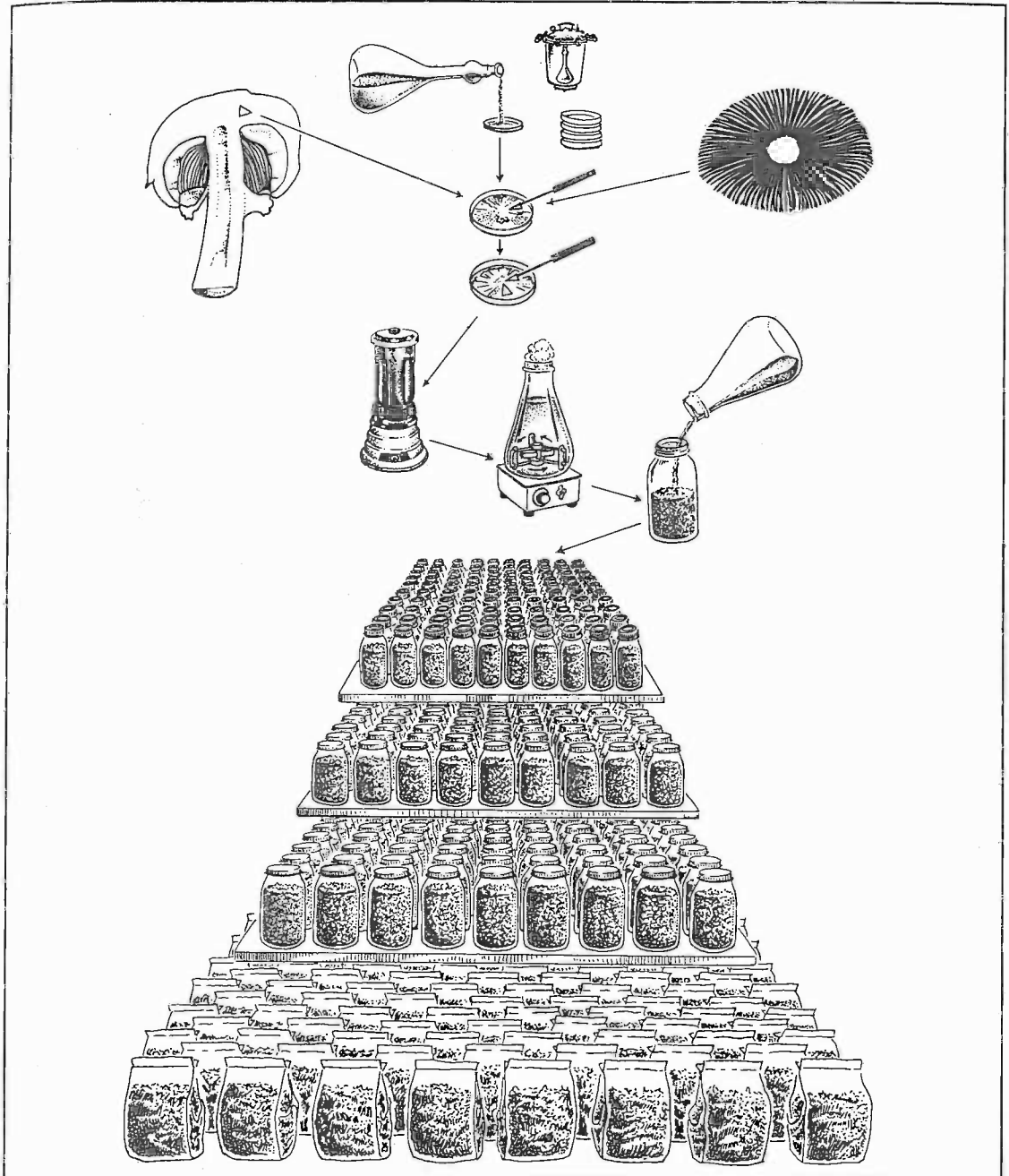

Figure 119. Expanding mycelial mass using a combination of liquid fermentation and traditional grain-transfer techniques. After fermentation for 3-4 days, 100 quart (liter) jars of sterilized grain are liquid-inoculated. These are denoted as  $G^1$  Masters. In 7-10 days, 1000- $\frac{1}{2}$  gallon (2 liter) jars are inoculated from these  $G^1$  masters. These are called  $G^2$ . Then, 10,000  $G^3$  gallon jars are inoculated from the  $G^2$ 's. Once grown through, 100,000 bags of sawdust spawn can be generated from the  $G^3$  jars. Each sawdust bag can be expanded by a factor of 10 into supplemented sawdust, creating 1,000,000 fruiting blocks. At 1-2 lbs. of mushrooms per block, more than 1,000,000 lbs. of mushrooms can be grown from one petri dish in as short as 80 days—depending upon the species and strain.

developed spore-mass inoculation techniques to an industrial level. Only recently have Western mycologists recognized that a large community of spore matings behaves quite differently than paired individuals. San Antonio and Hanners (1984) are some of the first Western mycologists to realize that grain spawn of Oyster mushrooms could be effectively created via spore-mass inoculation.

The most aggressive strains out-race the least aggressive strains to capture the intended habitat. Recent studies have shown that these aggressive strains over-power and invade the cellular network of competing strains. Dr. Alan Rayner (1988) in studies at the University of Bath, described this form of genetic theft as "non-self fusions" between genetically different mycelial systems within the same species. This ability to adapt has made fungi one of the most successful examples of evolution in the biological arena.

Spore-mass fermentation techniques are not yet widely used by North American or European cultivators. Concern for preserving strain stability, lack of experience, equipment, and intellectual conflict are contributing factors. In mushroom culture, intransigence to new ideas has prevailed, often because the slightest variation from the norm has resulted in expensive failures.

## Liquid Inoculation Techniques: Mycelial Fragmentation and Fermentation

This method differs from the spore-mass inoculation techniques in that the starting material is *dikaryotic mycelium*, not spores. In short, the cultivator chops up the mycelium into thousands of tiny fragments using a high speed blender, allows the mycelium to recover, and

transfers dilutions of the broth into jars or bags of sterilized grain. I prefer this technique as it quickly generates high quality spawn, eliminating several costly steps. Once perfected, most spawn producers find grain-to-grain transfers obsolete. The time not spent shaking the spawn jars frees the cultivator to attend to other chores. Most importantly, high-quality spawn is realized in a fraction of the time of the traditional methods. Step-by-step methods are described in the ensuing paragraphs. The ambient air temperature recommended throughout this process is 75° F. (24° C.).

**Step 1.** A vigorous, non-sectoring culture incubated in a 100 x 15 mm. petri dish is selected. This parent culture is subcultured by transferring one-centimeter squares from the mother culture to ten blank petri dishes. In effect, ten subcultures are generated. The cultures incubate until the mycelia reaches approximately 1 cm. from the inside peripheral edge of the petri dish, more or less describing a 80 mm. diameter mycelial mat.

**Step 2.** When the cultures have achieved the aforementioned growth, use the following formula to create a liquid culture media: After mixing and subdividing 750 ml. of the broth into three 1500 ml. Erlenmeyer flasks, the vessels are placed within a pressure cooker and sterilized for 1-2 hours at 15 psi (252° F. = 121° C.)\*

---

\* With experience, the cultivator will likely want larger vessels for fermentation. I prefer a 5000-7000 ml. squat glass flask, into which 2250 ml. of liquid culture media is placed, sterilized, and inoculated with 750 ml. of liquid inoculum. When the liquid volume exceeds 5000 ml. additional measures are required for adequate aeration, such as peristaltic pumps pushing air through media filters. The surface area of the liquid broth should be at least 110 mm./2000 ml. for sufficient transpiration of gases and metabolic by-products.

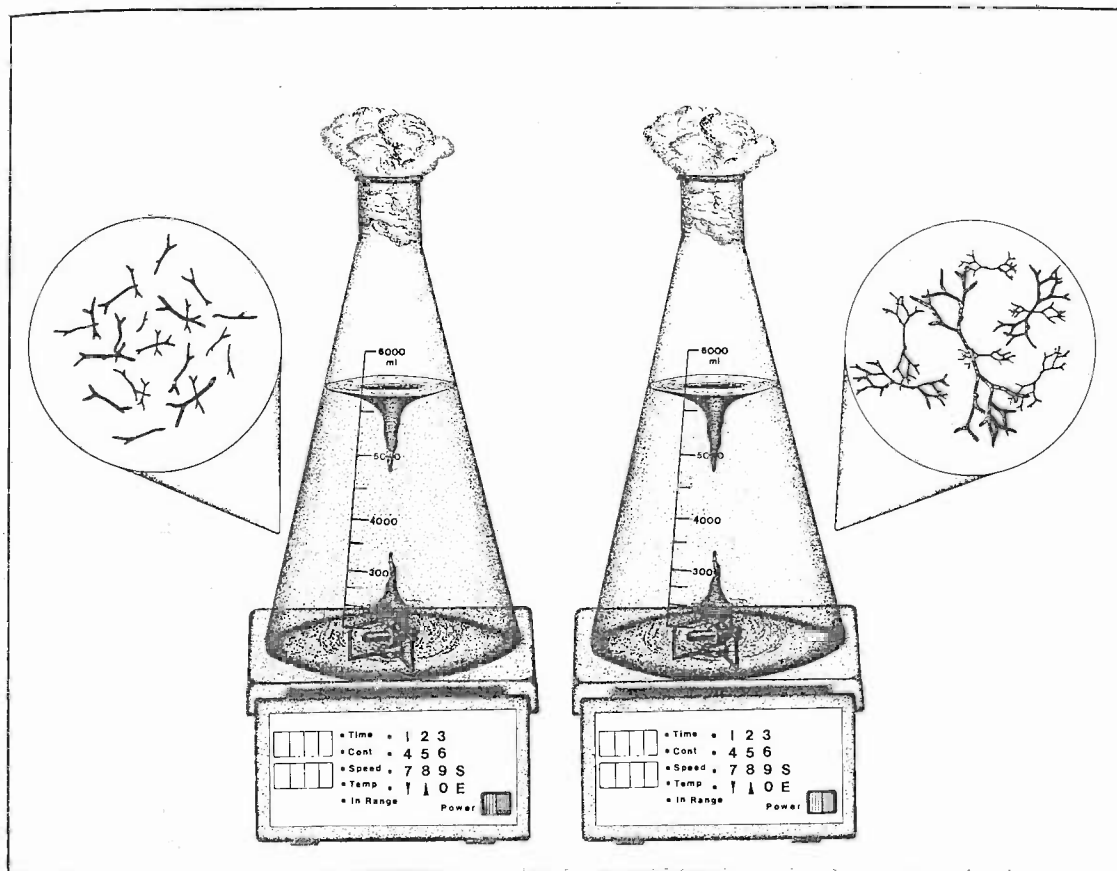

Figure 120. Actively growing mycelium 6 and 12 hours after inoculation.

### Stamets' Liquid Culture Media for Wood Decomposers

1000 ml. water  
 40 grams barley malt sugar  
 3-5 grams hardwood sawdust  
 2 grams yeast  
 1 gram calcium sulfate

Place a floating stir bar into each Erlenmeyer flask. The openings should be stuffed tightly with non-absorbent cotton and covered with aluminum foil. *The ingredients do not dissolve. The pH falls between 6.0-6.5 when using near-neutral water at make-up.*

First, a 1000 ml. Eberbach stirrer is filled

with 750 ml. of water and sterilized. Simultaneously, three 1500 ml. Erlenmeyer flasks, each containing 750 ml. of the above concoction, are sterilized. After sterilization, the pressure cooker naturally cools. If your pressure cooker *does not* form a vacuum upon cooling, then the Eberbach stirrer and the Erlenmeyer flasks *must* be removed at 1-2 psi., before reaching atmospheric pressure. Otherwise, contaminants are drawn in. The slightest mistake with this process could ruin everything that is inoculated downstream. If the pressure cooker *does* achieve negative pressure, the vacuum must be broken paying careful

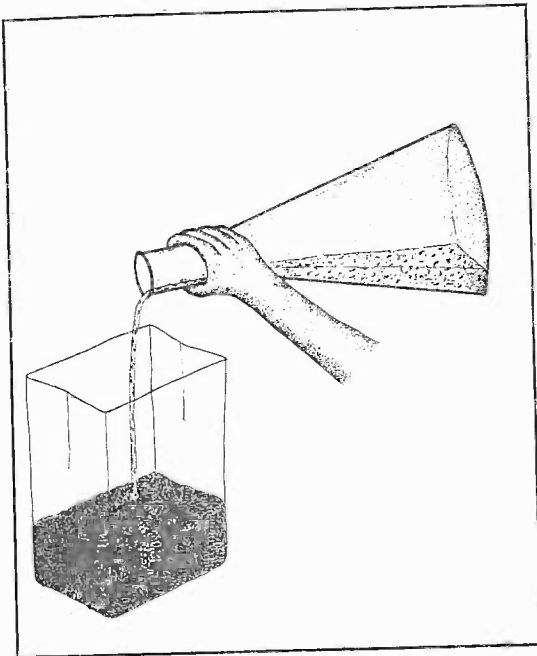

Figure 121. Free-pouring of fermented mushroom mycelium into sterilized grain to create Grain Spawn Masters.

attention to the path by which air is drawn in. The outer surface of the pressure cooker should have been wiped clean and placed into the airstream coming from the laminar flow bench. Since the airstream coming from the face of the micron filter is free of airborne particulates, the media remains sterile. Additionally, I like to saturate a sterilized cotton cloth (cotton baby diapers work well) with isopropanol and place it over the vent valve as an additional precaution. When the stop-cock is opened, clean air is drawn through the alcohol-saturated cloth. Once the pressure returns to normal, the pressure cooker is opened into the airstream, with the leading edge nearest to the filter. The contents are removed and allowed to cool. The cultivator should always remain conscious of the cleanliness of the surfaces of the pressure cooker, his hands, and the countertops upon

which items are placed.

**Step 3.** Of the ten cultures, the five best are chosen. Any culture showing uneven growth, sectoring, or any abnormality is viewed with suspicion and is excluded. The mycelium from each petri dish is sectioned into quadrants with a heat-sterilized scalpel and aseptically transferred into the Eberbach stirrer containing the sterilized water. Heat sterilization of the scalpel need only occur once. This is the single step that is most dependent upon the actions of the laboratory technician. Since five cultures are cut and transferred, the slightest mistake at any time will allow contamination to be passed on, thereby jeopardizing the entire run. Should the scalpel touch anything other than the cultured mycelium, it should be re-sterilized before continuing. Once the transfers are complete, the screw-top lid of the Eberbach is replaced, carefully adhering to the principles of standard sterile technique.

**Step 4.** The Eberbach stirrer is placed on the power unit and stirred in 3-second bursts. (The blender I use rotates at 8400 rpm.) Pausing for 5 seconds, the surviving chunks of agar fall downwards into the blades. Another 3-second burst decimates these pieces. One more 5-second pause is followed by the last 3-second, high-speed stir. In effect, the stirring process has created thousands of chopped strands of mycelium, in short cell chains.

**Step 5.** The water/mycelium blend is transferred, 250 ml. at a time in equal proportions, into the three 1500 ml. Erlenmeyers. A remote syringe, pipette, or liquid pump can be used. Less elaborate is to simply "free-pour" equal volumes of myceliated fluid from the Eberbach into each Erlenmeyer. The non-absorbent cotton stoppers are, of course, removed and replaced with each pouring, being careful not to allow contact between the cotton stopper and



**Figure 122.** Inoculating mycelium into an Eberbach holding sterilized water.

any contaminated surface. Each Erlenmeyer is placed on stir plates or on a shaker table and rotated at 100-200 rpm. for 48-72 hours. The water broth is continuously stirred to allow transpiration of metabolic gases and oxygen absorption. The fluid has a milky-brown color and is not translucent. Settling of the heavier components is clearly visible when the stirring process is interrupted.

Upon completion, 3000 milliliters of mycelium are rendered in liquid form. The hyphae, recovering from the damage of being cut by the spinning blades of the blender, are stimulated into vigorous re-growth. At a point several cells away from the cut ends, nodes form on the cell walls, new buds push out, and branch. A vast, interconnected fabric of cells, a mycelial network, forms. The branches fork continuously. *After two to four days of re-growth in the nutrient enriched broth, each Erlenmeyer flask*

*becomes its own universe, hosting thousands of star-shaped, three dimensional colonies of mycelium. This is the stage ideal for inoculation into sterilized substrates, especially in the generation of grain spawn masters. (See Figure 120). Far more bioactive than the same mycelium transferred from the two-dimensional surface of a petri dish, each hyphal cluster grows at an accelerated rate subsequent to transfer to the grain media.*

If, however, the liquid media is not used at its peak rate of growth, and stirs for nearly a week, the colonies lose their independence and coalesce into a clearly visible contiguous mycelial mat. Long mycelial colonies adhere to the interface of the fluid surface and the inside of the flask. Chains of mycelium collect downstream from the direction of rotation. Soon after their appearance, often overnight, the media becomes translucent and takes on a rich amber color. A large glob of mycelium collects on the surface and can be mechanically retrieved with a pair of tweezers, forceps, or scalpel, if desired. The remaining clear amber fluid contains super-fine satellite colonies and hyphal fragments. By passing the fluid through a microporous filter, the mycelium can be recaptured. This technique is especially attractive for those whose goal is running tests on small batches of mycelium. With many species I have grown, the conversion ratio of sugar/wood to mycelium (dry weight) approaches 20%. This percentage of conversion is nearly 80% biological efficiency, considered good in the commercial cultivation of gourmet mushrooms.

**Step 6** Each of the three Erlenmeyer flasks now contains 1000 ml. of nutrient, mycelium-rich broth. At 30 ml. per transfer, 100 1/2 gallon (2 liter) grain-filled jars can be inoculated. Here too, a pipette, back-filled syringe, burette, or pump can be used. I prefer "free-pouring" 30



Figure 123. A space-efficient rack for incubating grain spawn in jars. 340 1/2 gallon jars can be stored on this 8' long x 8' high x 16" wide shelf system. Spawn quality is improved by storing the jars at an angle. (Earthquake sensitive.)

ml. of myceliated broth directly out of each Erlenmeyer into each half gallon jar of sterilized grain. In time, an adept cultivator develops a remarkably accurate ability to dispense liquid spawn in consistently equal proportions. The spawn maker's movements become rapid, repetitious, and highly rhythmic.\*

One study, using a similar method (Yang and Yong, 1987), showed that the hyphal clusters averaged less than 2 mm. in diameter, and that each milliliter contained 1000-3500 "hyphal balls." The range of time for the maximum production of hyphal clusters varied between species, from two days to fourteen. The recommended inoculation rate was 15 ml. for each 250 grams of grain. For ease of handling, distribution and colonization, I find that the

dilution schedule described above efficiently inoculates large volumes of grain in the creation of grain masters. (30 ml. of inoculum is used to inoculate 500-600 grams of grain in 2-liter or 1/2-gallon jars). Most of the wood decomposers described in this book flourish with the aforementioned technique.

The lids to each container are replaced as soon as they are inoculated. If the lids to each jar are loosened prior to free-pouring, then one hand lifts each lid, while the other hand, pours the liquified mycelium into each jar, moving side-to-side. If an assistant is present, the jars are removed as soon as they are inoculated. As they are removed each lid is tightly secured and the jar is quickly shaken to evenly mix the liquid spawn through the grain. Each jar is stored at an angle on a spawn rack. One person inoculating in this fashion can keep two people busy "feeding" him new jars and removing those just inoculated. Since this system is fast paced, the time vector, the "window of vulnerability," is much less compared to the time-consuming, labor-intensive, traditional methods. The disadvantage of this technique, if there is one, is that the stakes for the clumsy spawn producer are higher. Any mistake will be amplified with force. Should any one of the petri dish cultures harbor contaminants, once that culture is placed together in the Eberbach stirrer, all resulting spawn jars will be contaminated. This is an all-or-nothing technique. Fortunately, if following the techniques outlined in this book, success is

\* Various laboratory pumps can be used for highly accurate injections of liquid media without danger of contamination. The Monostat Jr. Dispenser © (#54947-110), equipped with a foot switch, delivers shots of 10-50 ml. of liquid inocula per second utilizing a 5/16 in. silicon tube. If equipped with a multiple dispersion manifold, several spawn containers at once can be inoculated with ease and speed.

the norm.

The jars normally grow out in 4-7 days, many times faster than the traditional transfer technique *And the jars are only shaken once—at the time of liquid inoculation.* With the traditional wedge-transfer technique, each individual jar must be shaken two or three times to insure full colonization: first at inoculation; second after three days; and finally at days 5, 6 or 7. Remember, not only is the cultivator gaining efficiency using the liquid inoculation method, but 100 Grain Masters are created in a week from a few petri dish cultures. With less need for shaking, hand contact with the Grain Masters is minimized. Time is conserved. Probability of contamination is reduced. Growth is accelerated. With each kernel, dotted with stellar clusters of hyphae from the first day of inoculation, spawn quality is greatly improved.

As with any method described in this book, quality controls must be run parallel with each procedure. A sample of the mycelium-enriched broth is drop-streaked across the surface of a few nutrient-agar filled petri dishes. (See Figure 118). These will later reveal whether the liquid contains one organism—the mycelium—or a polyculture—the mycelium and contaminants. Furthermore, one or more of the sterilized grain-filled jars should be left unopened and uninoculated to determine the success of the sterilization procedure. These “blank” vessels should not spontaneously contaminate. If they do, then either the sterilization time/pressure was insufficient or airborne contamination was introduced, independent of the liquid fermented spawn. If the jars injected with the fermented mycelium contaminate, and the uninoculated controls do not, then obviously the vector of contamination was related to the act of inoculation, not the cycle of grain sterilization. (See Chapter 10: the Six Vectors of Contamination).

## Pelletized (Granular) Spawn

Trends in spawn technology are evolving towards pelletized spawn. Pelletized spawn is specifically designed to accelerate the colonization process subsequent to inoculation. Examples of pelletized spawn range from a form resembling rabbit food to pumice-like particles. In either case, they are nutrient-saturated to encourage a burst of growth upon contact with mushroom mycelium. Pelletized spawn varies in size from 1 mm. to 5 mm. in diameter.

Pelletized spawn can be made by adapting pelletized food mills designed for the manufacture of animal feeds. With modest re-engineering, these machines can be modified to produce spawn pellets. Idealized spawn seeks a balance between surface area, nutritional content, and gas exchange. (See Yang and Jong 1987; Xiang, 1991; Romaine and Schlaghauser, 1992.) A simple and inexpensive form of pelletized spawn can be made from vermiculite saturated with a soy protein-based nutrient broth.

The key to the success of pelletized spawn is that it enables easy dispersal of mycelium throughout the substrate, quick recovery from the concussion of inoculation, and ideally, the sustained growth of mycelium sufficient to fully colonize the substrate. Many grains are, however, pound-for-pound, particle-for-particle, more nutritious than most forms of pelletized spawn.

I believe the spawn should be used as the vehicle of supplementation into a semi-selective substrate. Others subscribe to the school of thought that the substrate's base nutrition should be raised to the ideal prior to spawning. The danger with this approach is that, as the base nutrition of the substrate is raised, so to is its receptivity to contaminants. From my expe-

riences, using a nutrition particle already encapsulated by mushroom mycelium is more successful. The ultimate solution may be a hybrid between liquid inoculum and grain spawn: a semi-solid slurry millimeters in diameter which would maximally carry water, nutrients, and mycelium.

### Matching the Spawn with the Substrate: Critical Choices on the Mycelial Path

Once spawn has been created, the cultivator arrives at a critical crossroad in the mushroom cultivation process. Several paths can be pursued for the growing of mushrooms, depending on the species and base materials. Some of these paths are intrinsically unproblematic; others are not. Success is measured by the following criteria: speed and quality of colonization, crop yield, and resistance to disease.

The first step can be the most critical. When trying to match a mushroom strain with an available substrate, I place a small sample of the substrate into the agar media formula. Upon exposure, the mushroom mycelium generates enzymes and acids to break down the proposed food source. Once acclimated, the mycelium carries a genetic memory of the end substrate to which it is destined. With Shiitake, Enokitake, Maitake, and Reishi, I acquaint the mushroom mycelium with the host substrate by introducing to the media a 1-2 gram sample of the sawdust directly into the liquid fermentation vessels. This liquid inoculum is then used to generate grain spawn. I am convinced that this method empowers the mushroom mycelium.

Grain spawn can be used for direct inoculation into pasteurized straw, into sterilized sawdust, or into enriched sawdust. If growing Oyster mushrooms, the recommended path is to inoculate straw with grain spawn. If one

wants to create plug spawn for the inoculation of stumps and logs, the best path is to go from grain spawn to sterilized sawdust, and once grown-out, to sterilized wooden dowels. For the rapid, high-yield methods of growing Shiitake, Enokitake, Maitake, Kuritake and others indoors on sterilized substrates, I recommend the following path: going from grain spawn to sterilized sawdust to enriched sawdust. Each transfer step results in an expansion of mycelial mass, usually by a factor of 5-10 and takes a week to two weeks to fully colonize.

The tracks recommended in the previous paragraph are the result of thousands of hours of experience. More direct methods can be used, but not without their risks. For instance, one can use grain spawn of Shiitake to inoculate enriched sawdust, skipping the above-described intermediate step of sawdust. However, several events are observed subsequent to inoculation. First, there are noticeably fewer points of inoculation than if sawdust spawn was used. As a result, recovery is slower and colonization is not as even. ("Leap off" is faster from sawdust spawn than from grain spawn. The mycelium has already acclimated to the sawdust substrate.) Most importantly, a marked increase in temperature occurs soon after inoculation, known by mushroom cultivators as *thermogenesis*. (See page 55). By enriching the substrate with grain spawn, increasing its nitrogen content, biochemical reactions are accelerated, and correspondingly two main by-products: heat and carbon dioxide. Should internal temperatures exceed 100° F. (38° C.) in the core of each bag, latent contaminants, especially thermophilic bacteria and black pin molds (*Aspergillus*, *Rhizopus*, and *Mucor*) spring forth, contaminating each and every bag. These same bags, incubated at 75 F. (24 C.) would otherwise be successfully colo-





Figure 124. Oyster mushrooms “breaking out” of a jar filled with grain spawn an event with potentially disastrous consequences for the laboratory.

nized with mushroom mycelium. *In general, the cultivator should assume that a minor population of contaminants will survive “sterilization” especially as the mass of each batch increases.* Thermotolerant contaminants are activated when temperatures within the substrate spiral upwards. To thwart this tragedy, the bags containing nitrogenous supplements should be spaced well apart when placed on open wire rack shelving. The laboratory manager should carefully monitor air temperature to off-set the upwardly spiralling trend of internal temperatures.

This arena of problems is largely avoided by using sawdust spawn for inoculation into supplemented sawdust substrates rather than grain spawn. Thermogenesis is reduced to a more manageable level. Colonization is faster, more even, and one gets more “mycelial mileage” from grain spawn by generating intermediate sawdust spawn.

In essence, another exponent of expansion of the mycelial mass has been introduced to the benefit of overall production.

In contrast, grain spawn is preferred over sawdust spawn for the cultivation of Oyster mushroom on cereal straws. Grain spawn boosts the nutritional base of straw, radically improving yields compared to using an equal mass of sawdust spawn. Although sawdust may have more points of inoculation, yields are substantially less than if the straw had been impregnated with grain spawn. Two exceptions are *Hypsizygus ulmarius* and *H. tessulatus*, both of which benefit when sawdust spawn is used to inoculate wheat straw.

In Chapter 21, the growth parameters of each species and the recommended courses for matching spawn and substrate for maximizing yields and minimizing problems are described in detail.

## Spawn Storage

Spawn can be stored for only a short period of time before a decline in viability occurs. Those who buy spawn from afar are especially at risk. As spawn ages, and with the depletion of food resources, the mycelium’s rate of growth declines. Metabolic wastes accumulate. With the loss of vitality, the mycelium’s anti-disease defensive mechanisms fail. Opportunistic molds, bacteria, viruses, and other microscopic organisms proliferate. Good quality spawn on Day 60 (from the date of inoculation) can be half as viable at Day 30.

Generally, spawn should be used at peak vitality. If it can not, only one option remains: refrigeration. Spawn can be refrigerated for several weeks at 35-40° F. (1.6-4.4° C.), effectively slowing its rate of decline, provided the refrigeration process does not, in itself, cause contamination to flourish. Spawn must not be

kept in a refrigerator in the same space as mushrooms are stored. The mushroom spores can become a vehicle of contamination bacteria and other fungi directly into the stored spawn. Spoiling mushrooms are often covered with the very contaminants so dreaded in the laboratory environment.

Another problem with refrigeration rooms is that the cooling of spawn causes condensation within the spawn containers. Free water, in the form of condensation, should always be viewed with concern by the cultivator. Contaminants proliferate within the water droplets and are efficiently spread by them. Bacteria, in particular, reproduce feverishly in free water environments, even at cool temperatures. Further, refrigeration blowers and cooling elements attract and collect dust particles, which inevitably must be cleaned. The force of the air blasting from the cooling elements covers the outer surfaces of the bags with contaminant particles that are easily transferred by anyone handling them. Most often, the filter media, designed to limit airborne contamination, become the sites of black and green mold growth. In time, they can penetrate from the outside into the interior environment of the spawn containers.

If refrigeration is your only alternative, then, by definition, you have missed the best opportunity: to use the spawn at its peak of vitality. Nevertheless, every spawn producer faces this dilemma. So, if you have to refrigerate your spawn, the following precautions are suggested.

1. Treat the refrigeration room as if it were a clean-room. Analyze all potential contamination vectors. Install a HEPA filter if necessary. Make sure floors and walls are kept clean by frequently washing with a 10% bleach solution.
2. Rotate your spawn! Only similarly aged spawn should be kept together.
3. When refrigerating spawn, use bags, not jars.

4. Inspect the stored spawn once a week for visible signs of contamination, especially at the location of the microporous filter patches. (Although spores may not pass through the filtration material, mold mycelia can.)

5. Maintain a low relative humidity. The humidity should never exceed 60%, and should ideally be kept in the 40-50% range.

6. Minimize any material which could become a platform for mold growth, particularly wood, cardboard, and other paper products.

Lastly, some species are more receptive to cold storage than others. Some of the tropical species die upon exposure to cold temperatures. (*Volvariella volvacea* is one notable example.) The cold-weather Oyster strains (*Pleurotus ostreatus* and allies) can be shocked into fruiting upon placement into a cold room. One commonly sees Oyster mushrooms fruiting frantically in containers which were otherwise hermetically sealed. The force of fruiting, the bursting forth of mushrooms within the spawn containers, can actually cause enough stress to split plastic seams, unscrew lids on bottles, and force apart filter membranes.

With the rapid-cycle spawn techniques described in this book, cold storage of spawn is not necessary and is not recommended. Cold storage is an option widely utilized by the *Agaricus* industry, an industry historically fractured into specialty companies. When inventories exceed demand, spawn is kept for as long as possible under refrigeration. Often the consumer, not knowing better, becomes the victim of a spawn producer's over-production. If the spawn fails, the excuse heard, more often than not, is that the spawn was mishandled by the purchaser. This type of business relationship is intrinsically problematic, and is yet another reason why mushroom farms should generate their own spawn.

## Creating Sawdust Spawn

**S**awdust spawn is simply created by inoculating grain spawn into sterilized sawdust. Hardwood sawdust, especially oak, alder, cottonwood, poplar, ash, elm, sweetgum, beech, birch and similar woods are best. Fresh sawdust is better than aged, and sawdust with dark zones (often a sign of mold infestation) should be avoided. Sawdust from milling lumber is best because of its consistent particle size, measuring, on average, 1-5 mm. in diameter. Sawdust from furniture manufacturers is much more difficult to formulate. Often this sawdust is either too fine and/or combined with shavings. With shavings, the mycelium must expend excessive cellular energy to span the chasms between each food particle. Per cubic inch, shavings are too loose a form of wood fiber, insufficient to support a dense mycelial mat let alone a substantial mushroom.

Sawdust is moistened 60-70% and scooped into gusseted polypropylene bags to a gross weight of 6 lbs. The open tops of the bags are folded down and stacked tightly into a square push-cart. This helps

the bags form into a cube. Should excess water become visible, collecting at the bottom of the bags, then less water is added at make-up. Fortunately, mycelium tolerates a fairly broad range of moisture content for the production of sawdust spawn.

Some spawn producers secure the open flaps of the bags with plastic tape, spring-activated clothes pins, even paper clips. To meet this need, a cultivator-mycologist named Dr. Stoller invented a specialized collar, filter, and lid combination which is still in use today. If the bags are carefully handled, however, many cultivators simply press adjacent bags tightly together, negating the need for fasteners. The bags are loaded into an autoclave or pressure cooker and sterilized for 2-3 hours at 15 psi. Upon return to atmospheric pressure and following the same procedures outlined for cycling grain spawn, the bags are removed from the pressure vessel directly into the clean room.

Each gallon (4 liter) of grain spawn can effectively inoculate ten 5 lb. bags of moist sawdust spawn. Exceeding 20 bags of sawdust inoculated per gallon of grain spawn is not recommended. Strict adherence to the sterile techniques previously outlined in this book must be followed during the inoculation process. I recommend washing your hands periodically with anti-bacterial soap (every 30 minutes) and frequently wiping them with isopropanol alcohol (every 10 minutes). Once inoculations are completed, those with delicate skin should use a moisturizer to prevent damage from disinfectants.

## Step-by-Step Instructions for Inoculating Sawdust

**1. Choosing the grain spawn.** Grain spawn should be selected from the laboratory inventory. Ideally, spawn should be 1-3 weeks of age,

at most 4 weeks. Carefully scrutinize the filter disc zone, inside and outside, to discern the presence of any molds or unusual signs of growth. Only cottony spawn, void of wet spots or areas of no-colonization, should be chosen. Since the spawn generally chosen is Second or Third Generation, bag spawn is preferred for this stage. The grain kernels of each spawn jar are loosened by shaking the bag or slamming the jar against a cleaned rubber tire or similar substance.

**2. Retrieving the bags from the autoclave.** Bags of sawdust, having been removed directly from the autoclave, cool to room temperature by being placed in the windstream of a laminar flow hood. Once the bags are below 100° F. (38° C.) inoculations can proceed.

**3. Opening the bags.** The bags are opened by *pulling the outside plastic panels outwards from the outside*. The inoculator's hands never touch the interior surfaces. If they do, contamination is likely. Once ten bags have been fully opened, the inoculator wipes his hands with isopropanol and brings a gallon of grain spawn to the table directly downstream from the newly opened bags. The jar lid is loosened to a point where it can be lifted off easily with one hand.

**4. Inoculating the bags in a specific sequence.** If using jar spawn, remove the lid and place it upside down, upstream and away from the bags to be inoculated. Since you may wish to return the lid to the spawn jar should all its contents not be used, pay attention to the manner in which it is handled. Grasping the spawn jar with one hand, palm facing up, position the jar opening above the first bag to be inoculated. If you are right handed, inoculate each sawdust bag in sequence going from left to right. (Left handers would logically do this in the reverse.) With a roll of the wrist, angle the jar so that grain spawn free-falls into the opened bag. The spawn



Figure 125. Sawdust spawn of Reishi (*Ganoderma lucidum*). Note inflated atmosphere within bag.

must be well separated for this technique to result in a consistent rate of inoculation for each bag. Through trial-and-error and experience, a highly rhythmic and exact amount of spawn is apportioned amongst the ten sawdust bags.

If there are, for instance, 4 rows of 10 bags in front of the laminar flow bench, then a right-handed person would inoculate bags starting from the far left, rear bag. Each bag to the right would then be inoculated until the back row is finished. In turn, the third row would then be inoculated with the next gallon of grain spawn, again from left to right. In this fashion, the hands of the inoculator can not jeopardize the sanctity of the upstream bags. To inoculate the first row nearest to the face of the micron filter would endanger downstream bags from the debris coming from the inoculator's hands and/or undetected contaminants from a spawn jar.

**5. Sealing the sawdust spawn bags.** Few steps are as critical as this one. The simple mechanical act of sealing sterile airflow bags can have extraordinarily disparate results for the success of the spawn incubation process. All other steps in this process can be perfectly executed, and yet failure to achieve a continuous seal can be disastrous.

I attempt to create a positively inflated bubble at the time of sealing. (See Figure 129). Although the filter patch allows the transpiration of gases, it is not at a rate that causes the bag to noticeably deflate, even with gentle squeezing. When this bubble environment is created at the time of sealing, two advantages are clearly gained. First, the grain spawn mixes and rotates easily through the sawdust, making shaking easy. Secondly, each bag now has a voluminous plenum, a mini-biosphere with an



Figure 126. Universal hand position used for opening bags, lifting petri dish lids, and removing spawn jar caps.



Figure 127. Inoculating sawdust with grain spawn

atmosphere nearly matching the volume of the sawdust. (At least 25% air space should be allotted per spawn bag; otherwise anaerobic activity will be encouraged.)

The open bag is laid horizontally, with its opening overhanging the heating element. Grasping both the left and right outside surfaces, the bag opening is pulled open to catch the sterile wind. A "Spock-like" finger position keeps the bag maximally inflated while the heat sealer joins the plastic. (See Figure 126.) Two strokes are often necessary for a continuous seal. By gradually increasing the duration of the seal, an ideal temperature can be found. Since the plastic liquifies upon contact with the heating element, the bags should not be squeezed during sealing.

Pinholes or small tears cause the bags to collapse. Collapsed bags contaminate with alarming frequency. A simple test determines

if the problem is at the seal or not. Roll the sealed region several times into a tight fold and push down. The bag inflates and if there is a leak *not* at the seal, a distinct hissing sound emanates from the defective site. Should the bag remain tightly inflated with no apparent loss of pressure, then the seal at the top is at fault. Simply re-seal and test again for leaks.

**6. Shaking the sawdust spawn bags.** Once the bags have been properly sealed, they are thoroughly shaken to evenly distribute the spawn kernels. If partially inflated, this process takes only a few seconds. Proper shaking is critical for successful spawn incubation. (See Figure 129).

**7. Incubating the sawdust spawn bags.** Unlike nutrified sawdust, most sawdust bags contacting each other during incubation grow out without contamination. The laboratory space can be maximized with sawdust spawn.



Figure 128. Sealing the bag of sawdust after inoculation with grain spawn.



Figure 129. Dispersing the spawn throughout the sawdust by shaking. The inflated bag not only facilitates shaking, but provides a sufficient atmospheric plenum within each bag, accelerating the growth of the mushroom mycelium.

By placing a small thermometer between the two faces of the touching bags, the laboratory manager can track temperatures to be sure they do not stray into the danger zone of  $>95^{\circ}\text{F}$ . ( $35^{\circ}\text{C}$ ). Above this temperature, thermophilic fungi and bacteria reign.

In 3 days, recovery from the concussion of inoculation is clearly visible from the grain kernels. The kernels become surrounded by fuzzy mycelium. Looking at a population of bags on a shelf from afar quickly tells the laboratory manager how even the spawn run is. Concentrated pockets of growth, adjacent to vast regions of no growth, result in poor completion. If evenly inoculated, the sawdust spawn is ready to use within two weeks.

Sawdust spawn is used for one of five purposes:

- to sell to log growers
- to inoculate outdoor beds by dispersing the spawn or by burying the block into the ground.
- to inoculate sterilized hardwood dowels in the creation of plug spawn for log and stump growers
- to grow mushrooms on. (However, most of the species described in this book benefit from having the sawdust enriched with a readily available, nitrogenous supplement such as bran.)
- to inoculate 5-20 times more sterilized enriched sawdust, usually sawdust supplemented with nitrogenous sources such as rice bran, soy bean flour, etc.







# Growing Gourmet Mushrooms on Enriched Sawdust

**W**hen sawdust is supplemented with a nitrogen-rich additive, the yields of most wood-decomposers are enhanced substantially. Rice bran is the preferred additive in Asia. Most brans derived from cereal grains work equally well. Rye, wheat, corn, oat, and soybean brans are commonly used. Flours lack the outer seed coat and, by weight, have proportionately more nutrition than brans. Other more-concentrated nitrogen sources such as yeast, soy oil, and peptone require precise handling and mixing at rates more dilute than bran supplements. The nutritional tables in Appendix V will help cultivators devise and refine formulas. Mini-trials should be conducted to prove suitability prior to any large-scale endeavor.

For the cultivation of Shiitake (*Lentinula edodes*), Enokitake (*Flammulina velutipes*), Maitake (*Grifola frondosa*), Kuritake (*Hypholoma sublateritium*), Lion's Mane (*Hericium erinaceus*), The Black Poplar (*Agrocybe aegerita*), and Nameko (*Pholiota nameko*), the following formula is recommended. Alterations to the formula

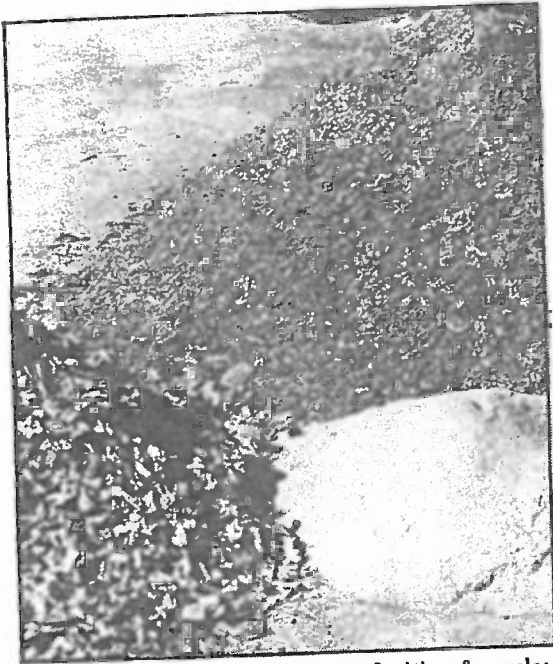

Figure 130. Components for the fruiting formula: sawdust, chips, and bran.

will further enhance yields for each strain. I find this formula to be highly productive and recommend it highly.

The base substrate is composed of fast-decomposing hardwoods, such as alder, poplar, and cottonwood in contrast to the slow-rotting woods like oak and ironwood. If these types of quick-rotting woods are unavailable, deferment should first be made to the tree types upon which the mushroom species natively inhabits. Most of the photographs in this book are from blocks made with this basic formula.

I have devised the following *fruiting formula* utilizing hardwood sawdust, hardwood chips, and a nitrogen-rich supplement, in this case rice bran. Water is added until 65-75% moisture is achieved, a few percentage points below saturation.



Figure 131. Adding the supplement (bran) to hardwood sawdust.

## The Supplemented Sawdust “Fruiting” Formula: Creating the Production Block

This formulation is designed for maximizing yields of wood-decomposers. Most gourmet and medicinal mushrooms produce prolifically on this substrate. If wood is a scarce commodity and not available as a base component, please refer to Chapter 18.

### The Sawdust/Bran Fruiting Formula

- 100 pounds sawdust
- 50 pounds wood chips (1/2-4 inches)
- 40 pounds oat, wheat, or rice bran
- 5-7 pounds gypsum (calcium sulfate)\*

By dry weight, the fraction of bran is approximately 20% of the total mass. By volume

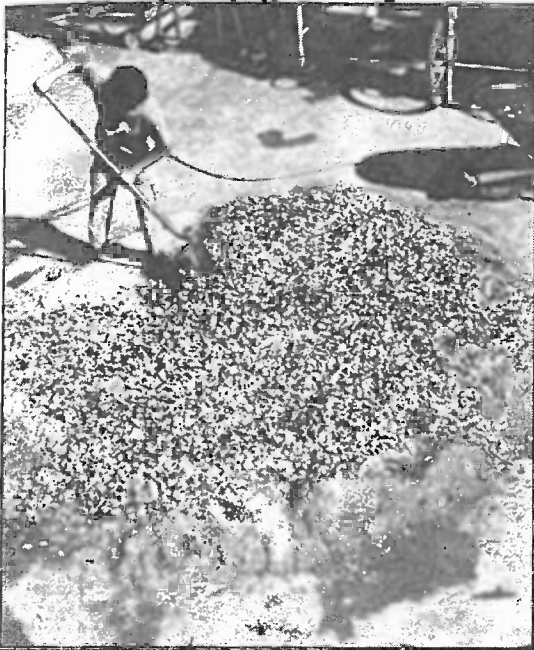

Figure 132. Adding 2-3" diameter wood chips on top which builds the matrix.



Figure 133. The ingredients are thoroughly mixed.

this formula is equivalent to:

- 64 gallons sawdust
- 32 gallons wood chips
- 8 gallons bran
- 1 gallon gypsum (calcium sulfate)\*

The above-mentioned mixture fills 160-180 bags of moist sawdust/bran to a wet mass between 5.0 and 5.5 lbs. I recommend using a standardized volumetric unit for ease of handling, anything from a plastic 4-gallon bucket to the scoop bucket of a front end loader. In either case, simply scale up or down the aforementioned proportions to meet individual needs. Thorough mixing is essential.

The above weights of the sawdust and chips are approximate, based on their ambient, air-dried state. (The wood used, in this case, is red alder, *Alnus rubra*, and is highly recommended.) Bran should be stored indoors, away from moisture, and off the ground to prevent

souring. Rice bran readily contaminates and must be carefully handled. Molds and bacteria flourish in nitrogen-rich supplements soon after exposure to moisture.

Using a four-gallon bucket as a measurement unit, 16 buckets sawdust, 8 buckets chips, and 2 buckets bran lie ready for use. All three are mixed thoroughly together in dry form, then gypsum is added, and the final mixture is

\* Raaska (1990) found that the use of calcium sulfate (gypsum) stimulated mycelial growth of Shiitake in a liquid media supplemented with sawdust. The calcium sulfate did not, by itself, significantly affect pH at make-up. However, mycelial growth was stimulated by its addition, and there was a corresponding precipitous decline of pH and a four-fold increase in biomass vs. the controls. Leatham & Stahlman (1989) showed that the presence of calcium sulfate potentiated the photosensitivity of the Shiitake mycelium, affecting fruitbody formation and development. A beneficial effect of calcium sulfate on the growth rate of other wood decomposers is strongly suspected.

moistened to 60-65%. This formula makes 160-180 bags weighing 5.5 lbs. Directly after make-up the bags are loaded into the autoclave for sterilization. Should the mixture sit for more than a few hours, fermentation reactions begin. Once bacteria and molds flourish, the mixture is rendered unsuitable.

If alder is unavailable, I strongly encourage substituting other rapidly decomposing hardwoods, such as cottonwood, poplar, willow, sweetgum, and similar wood types from riparian ecosystems. Although oak is the wood most widely used in the cultivation of Shiitake, Maitake, and Enokitake, its inherent, slower rate of decomposition sets back fruiting schedules compared to the above mentioned hardwoods. Sycamore, mahogany, ironwood, the fruit trees, and other denser woods require a



**Figure 134.** The mixture featured in Figures 130-133 created 180 6 lb. bags of the fruiting formula. Once mixed and wetted, this mixture must be immediately loaded into the autoclave and sterilized.

longer gestation period, although subsequent fruitings may benefit from the increased wood density.\* Here, a little experimentation on the part of the cultivator could have far-reaching, profound results. Mini-trials matching the strain with the wood type *must* be conducted before expanding into commercial cultivation.

By laying out the sawdust first in a 10 x 10 foot square, the chips can be thrown evenly upon the sawdust, and topped by broadcasting rice bran evenly over the top. This mass is mixed thoroughly together by whatever means available (flat shovel, cement or soil mixer, tractor). A mixer of less than a cubic yard in capacity is probably not more efficient than one person mixing these three ingredients by hand with a shovel. Pockets of discoloration, mold, or "clumps" should be avoided during the making up of this composition. The more competitors at make-up mean the more that are likely to survive the "sterilization" cycle.

Mixing the above components by hand becomes functionally impractical beyond 300 bags per day. At this level of production and above, automated mixing machines and bag fillers, adapted from the packaging and nursery industry, are far more efficient in terms of both time and, in most cases, money invested.

## Testing For Moisture Content

Wetting the substrate to its proper moisture content is critical to creating a habitat that encourages mycelial growth while retarding

\* If speed of production is not the over-riding issue, then many of these denser hardwoods, such as the oaks, may produce better-quality fruitings over the long term than those from the rapidly decomposing hardwoods. However, I have found Enokitake, Oyster, Reishi, Lion's Mane and Shiitake to give rise to faster fruitings of equally superior quality on alder, poplar and cottonwood.

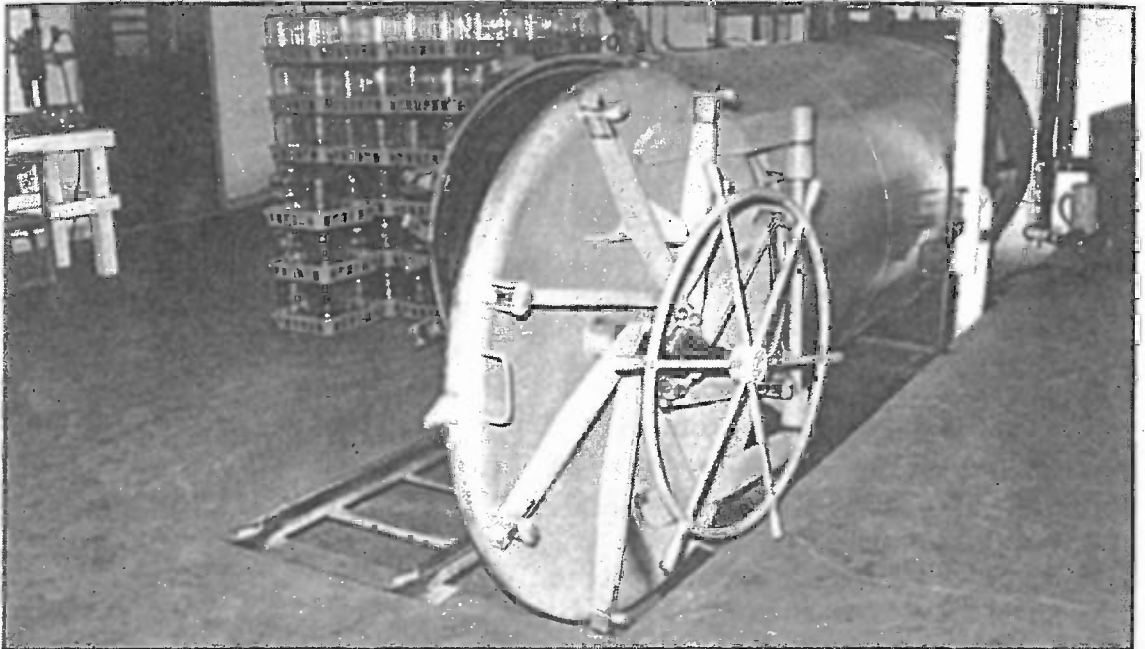

Figure 135. Commercial double door steam sterilizer.

contamination. If too much water is added, exceeding the carrying capacity of the media, the excess collects at the bottoms of the bags, discouraging mycelium and stimulating bacterial blooms and anaerobic activities. Ideally, sawdust is wetted to 60-65% water. If the wetted mix can be squeezed with force by hand and water droplets fall out as a stream, then the mix is probably too wet.

The easiest way to determine moisture content is by gathering a wet sample of the mixture, weighing it, and then drying the same sample in an oven for 1 hour at 350° F. (180° C.) or in a microwave for 10-15 minutes. If, for instance, your sample weighed 100 grams before drying, and only 40 grams after drying, then obviously 60 grams of water were lost. The moisture content was 60%.

Once the person making the substrate obtains experience with making up a properly

balanced substrate, moisture content can be fairly accurately determined by touch. Materials are measured volumetrically, correlated to weights, for ease of handling. This insures that the mixing proceeds with speed and without unnecessary interruption.

### Choosing a Sterilizer, a.k.a the Retort or Autoclave

Although home-style pressure cookers are ideal for sterilizing agar media and for small-to-medium batches of grain, they have insufficient capacity for the sterilization of bulk substrates. The problems faced by the mushroom cultivator in Thailand or the United States are the essentially the same. In developing countries, the sterilizer is often a make-shift, vertical drum, heated by fire or gas. A heavy lid is placed on top to keep the contents contained. The boiling of water generates

steam, which over many hours, sufficiently sterilizes the substrate. This method works well within the model of many rural agricultural communities.

The pressurized steam autoclave is far better suited for commercial production. The most useful autoclaves for sterilizing bulk substrates are horizontal and have two doors. (See Figure 134) Since the autoclave is the centerpiece upon which the entire production process is dependent, many factors must be considered in its acquisition: size; configuration and placement. Another important feature is its ability to hold a vacuum subsequent to the sterilization cycle. If the autoclave can not hold a vacuum as it cools, a valve should be installed for the controlled intake of filtered air. If the influx of air is not filtered, the contents can contaminate after sterilization. (See Figure 137.)

Hospital autoclaves are typically made of stainless steel and equipped with a pressurized steam jacket. These types of autoclaves are usually smaller than those needed by commercial mushroom cultivators, measuring only 2 x 3 ft. or 3 x 4 ft. by 3-6 ft. deep. Furthermore, they usually have only one door, and their pressure ratings have been engineered to operate at 100 psi, far exceeding the needs of most mushroom growers. Unless obtained on the surplus market for a fraction of their original cost, most knowledgeable spawn producers avoid these types of autoclaves. The most cost-effective vessels are those developed for the canning industries. These are commonly called "retorts" and are constructed of steel pipe, 1/4 to 3/8 inch thick, and ideally fitted with doors *at both ends*. The doors come in a variety of configurations. Quick-opening, spider doors are popular and durable. Wing-nut knock-off doors are slower to open and close but are less expensive to have

fitted onto steel pipe. With autoclaves longer than 6 feet, steam spreader pipes are needed so that the entire mass heats up evenly. More suggestions follow for choosing an autoclave:

### Recommendations for equipping an autoclave:

- Double-doors (i.e. doors at both ends)
  - Redundant pressure/temperature gauges (at least two)
  - Pressure/Vacuum Gauge (+ 50 psi to - 50 psi) w/valves
  - Electrical safety interlocks with warning lights
  - Hand-operated vent valve on top of autoclave for venting cold air
  - 25 psi and 50 psi excess-pressure relief, safety blow-out valves
  - Hand-operated drain valve for drawing off condensate
  - Coated with heat-resistant, anti-corrosive paint
  - At least four 1 inch, and/or two 2 inch ports for inputs, exhausts, and sensors.
  - One-way gate valve in series with a vacuum gauge that allows the drawing in of clean-room air post autoclaving. (See Figure 137.)
- ### Recommendations for the placement of the autoclave:
- Recessed "wells" (2 ft. x 3 ft. x 2 in.) underneath each door, with sealable drains, for removing excess condensate from the autoclave after opening.
  - Length of autoclave framed in its own insulated room (R=18 to R=32 with active exhaust (500+ CFM.))
  - One door of autoclave opens into clean room.
  - Escape doors located remote from the door seals of the autoclave should metal fatigue suddenly release an impassable curtain of steam.

## Sterilization of Supplemented Substrates

Once the bags are filled, the supplemented (sawdust) substrate must be heat treated for an extended period of time before inoculations can proceed. In a small pressure cooker, two to three hours of sterilization at 15 psi or 250°F. usually suffices for supplemented sawdust substrates. When sterilizing more than 100 bags in a large pressure vessel, however, the thermodynamics of the entire mass must be carefully considered in choosing a successful sterilization protocol. Hundreds of bags tightly packed in an autoclave achieve different degrees of "sterilization." When bags are stacked against one another, the entire mass heats up unevenly. Even so, this practice is common with those whose autoclaves must be packed to capacity in order to meet production requirements. Bear in mind that sawdust has high insulating properties, making heat penetration through it difficult.

Other factors affect the minimum duration of sterilization. The substrate mixture should be wetted just prior to filling. If water is added to the formula and allowed to sit for more than 6 hours, legions of contaminants spur to life. The more contaminants at make-up, the more that are likely to survive the sterilization cycle.

Fresh hardwood sawdust needs 2-3 hours of sterilization at 15 psi or 250°F. The same mass of sawdust supplemented with rice bran needs 4-5 hours of sterilization. Hence, one of the cardinal rules of mushroom culture: *as the percentage of nitrogen-supplements increases relative to the base substrate, the greater the likelihood of contamination, and thus the greater the need for full and thorough sterilization.*

I prefer the aforementioned formula using

alder sawdust, alder chips, and rice bran. An autoclave filled tightly 5 bags high, 6 bags wide, and 8 bags deep (240 bags) *requires exposure to steam pressure for 5 hours at 18 psi to assure full sterilization.* The lower, central core is the slowest to heat up. (See Figure 136.) By placing, heat-sensitive sterilization indicator strips throughout the mass of sawdust filled bags, a profile of sterilization can be outlined. Each cultivator must learn the intricacies of their system. Since the combination of variables is too complex to allow universal judgments, each cultivator must fine tune his techniques. Even the type of wood being used can influence the duration of the sterilization cycle. Woods of higher density, such as oak, have greater thermal inertia per scoop than, say, alder. Each run through the autoclave is uniquely affected by changes in the substrate formulation.

Those with ample space in their autoclaves separate the layers so thermal penetration is uniform. This is ideal. The sterilization cycle can be shortened, again best affirmed by sterilization-sensitive markers. However, few individuals find themselves in the luxurious position of having an autoclave capable of running several hundred bags *with* one or two inches of separation between the layers of bags. These one or two inches could be used to increase the capacity of the run by approximately 20%. Many small scale cultivators are soon forced to maximum capacity as their production expands with market demand. In the long run, dense packing is generally more cost-efficient compared to loose packing. Hence, dense packing, although not the best method, is usually the norm not the exception with the small to mid-size cultivator. Thus, the manager of the autoclave cycle operates from a precarious decision-making position, constantly juxta-

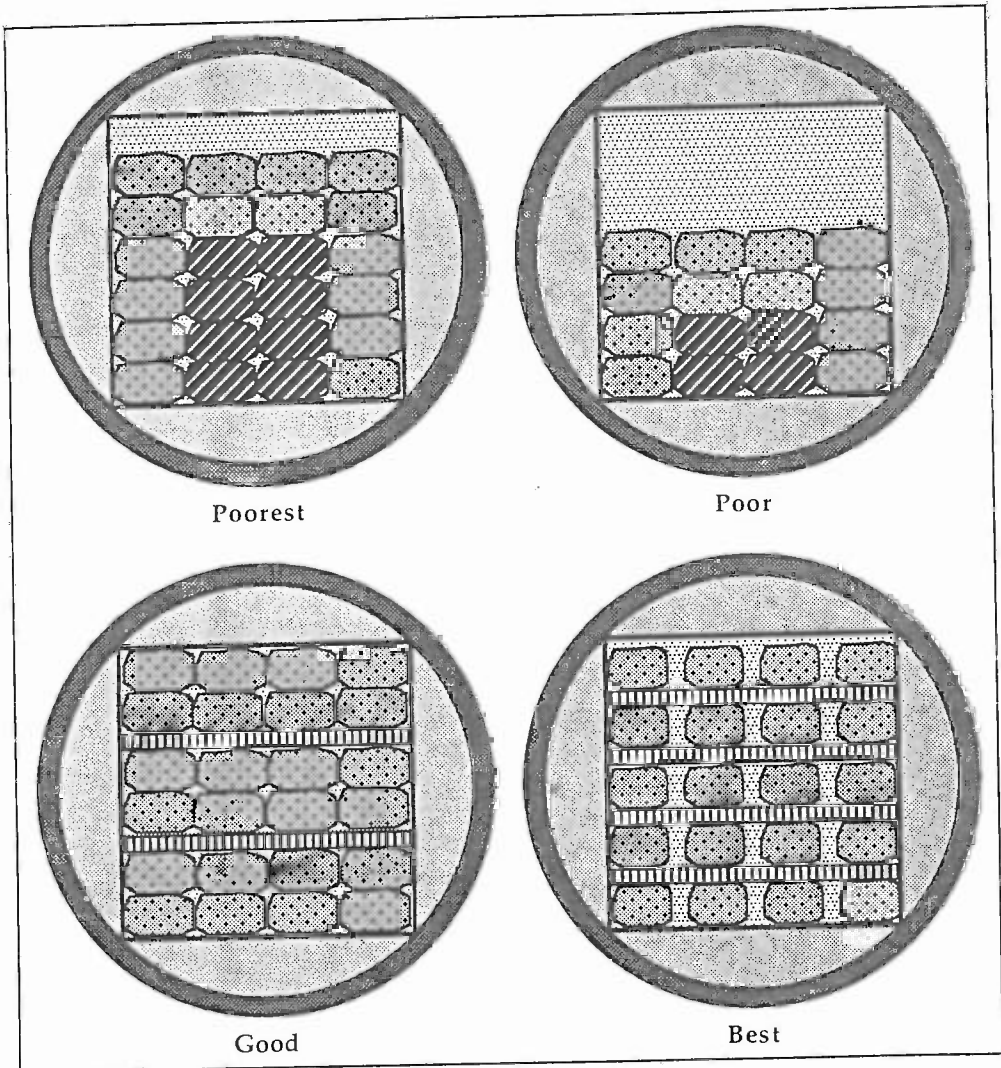

Autoclave Cross-Sections Showing Density of Fill

Figure 136. Four profiles depicting the degrees of sterilization as affected by the method of packing the bags into the autoclave. Note central, lower core is most resistant to deep steam penetration.



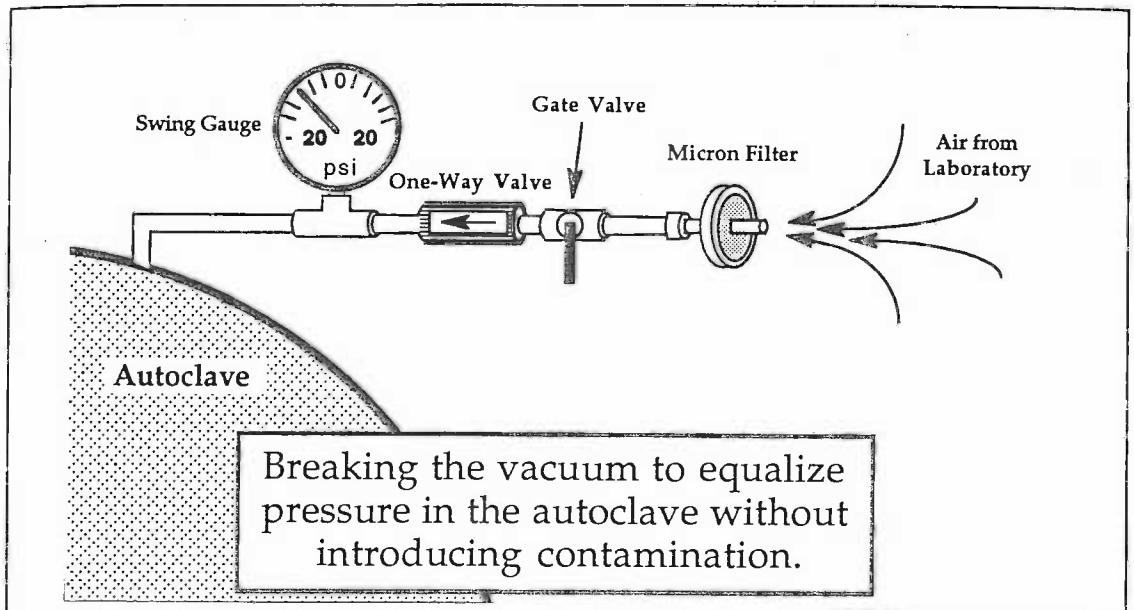

Figure 137. A microporous filter canister is attached to a pipe equipped with a gate valve which in turn is connected to a one-way check valve leading directly into the autoclave. Located on the clean-room side, this design allows pressure to be equalized in the autoclave after the sterilization cycle without introducing contaminants.

posing the needs of production and the dangers of uneven sterilization due to heavy loading.

Packing an autoclave deeper than 4 bags (32 inches deep) runs other contradictory risks. In the attempt to achieve full colonization, sterilization time is typically extended, potentially causing other problems: over-sterilization of the outer zones and bag-fatigue. Over-sterilization usually occurs when wood substrates are subjected to steam pressure (15-18 psi) for more than five hours. The sawdust takes on a dark brown color, has a distinctly different odor signature and, most importantly, resists decomposition by mushroom mycelium. Prolonged steam sterilization results in complex chemical transformations. (I have yet to find a chemist who can adequately explain what happens from prolonged exposure). Suffice it to say that turpentine, changes in

volatile oils, and toxic by-products are responsible for this radical shift in sawdust's myco-receptivity. In the end, the substrate is rendered entirely inhospitable to mushroom mycelium.

After the autoclave has been packed, the displacement of the cold air by introducing steam and top-venting is absolutely critical. The cold air, if not vented, gives a false temperature/pressure reading. At 15 psi, the temperature within the autoclave should be 252° F. (121° C.). This arithmetic relationship between temperature and pressure is known as Boyle's Law. When a cold mass is introduced into an autoclave or pressure cooker, Boyle's Law does not come into play until the thermal inertia of the affected mass is overcome. In other words, as hot steam is being forcibly injected into the vessel, there is a lag time as the heat is absorbed

by the cold mass. (This causes considerable condensation within the autoclave.) Thermal inertia is soon overcome, and Boyle's Law becomes operative.

Many autoclaves not only have a combined pressure/temperature gauge but also sport a separate, remote bulb sensor that records temperature deep within the autoclaved mass. This combination enables the laboratory personnel to compare readings between the two gauges. The duration of the autoclave run should not be timed until these differentials have been largely eliminated. (A differential of 10° F. should be considered negligible.) In real terms, the differential is normally eliminated within two hours of start-up. Obviously smaller vessels have reduced differentials while the most massive autoclaves have substantial contradictions between pressure and temperature readings. Since the duration of "sterilization" is critical, careful consideration of these temperature trends can not be underemphasized. Cultivators often mistakenly believe that the mass has been autoclaved sufficiently when only partial sterilization has been effected. Discarding several hundred bags due to insufficient sterilization is a strong incentive for cultivators to understand the nuances of autoclave cycling. Redundant gauges are recommended since devices fail over time.

## Post-Autoclaving

When the steam supply to the autoclave is cut off, pressure and temperature precipitously decline. Ideally, your autoclave should achieve a vacuum as it cools. If your autoclave or steam box does not have a tight seal, and can not form a vacuum, provisions must be made so that the air drawn in is free of airborne contamination. This usually means the timely opening of the autoclave into the clean room air just as atmo-

spheric pressure is attained. Commonly, an autoclave can swing in pressure from 20 psi to -20 psi within several hours after steam injection has stopped. This radical fluctuation in pressure further enhances the quality of the sterilization cycle. A 40-psi pressure swing is devastating at the cellular level, disabling any surviving endospores of bacteria or conidia of contaminating molds.

## Unloading the Autoclave

Once the autoclave has achieved a vacuum, the pressure must be returned to atmospheric before the door can be opened. Ideally, a gate valve has been installed on the clean room side, on a pipe connected to the combination pressure/vacuum gauge. A microporous filter canister can be attached for further insurance that the rush of air into the autoclave does not introduce contaminant spores. (See Figure 137). When the pressure has equalized, the next step is to open the drain valve to draw off excess condensate. Several gallons of condensate is common. After a few minutes, the autoclave door on the clean room side can be opened.

If the mass has just been autoclaved, the containers will be too hot to unload by hand unless protective gloves are worn. With the door ajar, several hours of cooling are necessary before the bags can be handled freely. Bear in mind that, as the mass cools, air is being drawn in. If that air is full of dust, contamination is likely. I like to thoroughly clean my laboratory while the autoclave is running. I remove any suspicious cultures, vacuum and mop the floors, and wipe the countertops with alcohol. In a separate pressure cooker, I autoclave towels, extra water, and other equipment essential to the impending inoculation cycle. Selected personnel for laboratory work wear laboratory garments

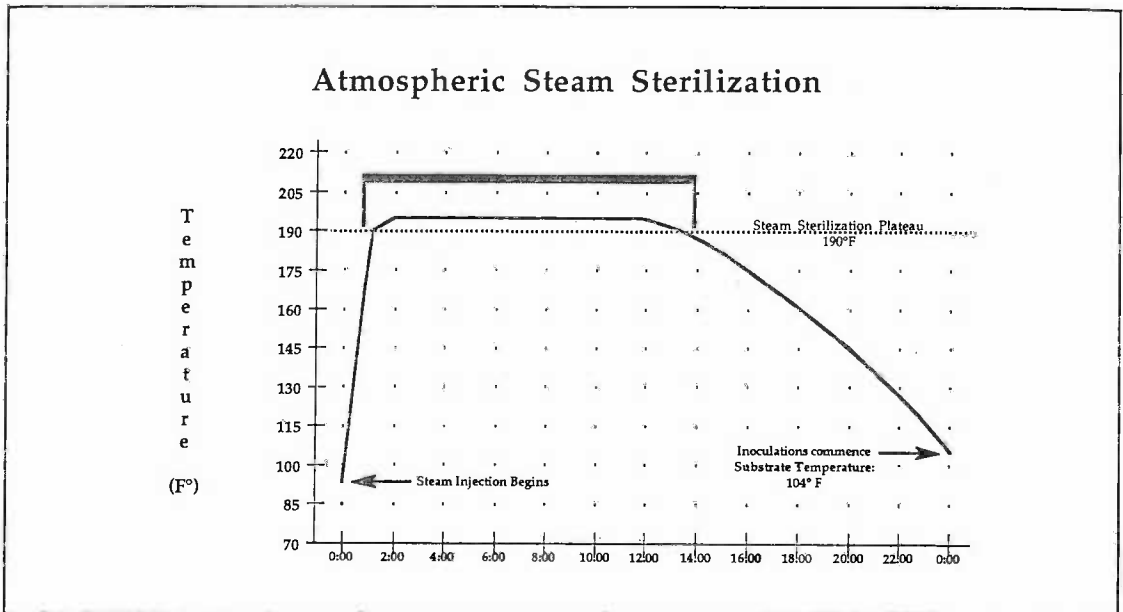

Figure 138. Profile of Atmospheric Steam Sterilization also known as Super-Pasteurization, an alternative method for sterilizing sawdust-based substrates.

or freshly laundered clothes.

Many spawn producers autoclave on one day, allow the vessel to cool overnight, and open the vessel the next morning. Depending on the mass of the autoclaved material, 12-24 hours may pass before the internal temperatures have fallen below 100° F. (38° C.), the minimum plateau for successful inoculations. Some of the better equipped spawn producers have large laminar flow hoods, even laminar flow “walls” in whose airstream the sterilized mass cools prior to inoculation.

### Atmospheric Steam Sterilization of Sawdust Substrates

Many cultivators can not afford, nor have access to large production-style autoclaves. The size of the sterilization vessel is the primary limiting factor preventing home cultivators

from becoming large-scale producers. Fortunately, alternative methods are available. Whereas straw is pasteurized for 1-2 hours at 160° F. (70° C.), supplemented sawdust is sterilized only when exposed to steam for a prolonged period of time. Many cultivators retrofit the cargo-style containers used in shipping in a fashion similar to a Phase II chamber. Large-capacity commercial laundry washers, cement mixers, cheese-making vats, beer fermentation vessels, railroad cars, semi-truck trailers, grain hoppers and even large diameter galvanized drain pipe can be retrofitted into functional steam chambers for the bulk processing of wood or straw-like substrates.

Once filled to capacity with bags of supplemented sawdust, steam is forcibly injected bringing the mass of the substrate to 190° F. (90° C.) for a minimum of 12 hours. Since water at sea level boils at 212° F. (100° C.), the mass of sawdust can not be elevated beyond



Figure 139. Bags of Shiitake mycelia incubating on sterilized sawdust. Note that bags are narrowly spaced, but are not touching, which aids in the loss of heat.

212° F. unless the pressure within the vessel is raised above 1 psi. I call this method *atmospheric sterilization* or *super-pasteurization*.

Most competitor organisms are easily killed with steam heat, with the exception of some thermotolerant black pin molds, and endospore-forming bacteria. Every microcosm, every microscopic niche, must be subjected to 250° F. (121° C.) for at least 15 minutes to effect true sterilization. When processing tons of sawdust, true sterilization is rarely achieved. The cultivator must constantly compromise the ideal in favor of the practical. To this end, temperature-sensitive indicator strips help the cultivator determine sterilization profiles. If sawdust is treated in bulk and not separated into individual bags, the danger of cross-contami-

nation is likely during the unloading and spawning process.

After 12 hours of heat treatment, the steam is shut off. As the mass cools, air will be drawn into the sawdust. The cultivator must take precautions so that contaminants are not introduced. The best alternative is to design the inoculation room with a positive-pressurized HEPA filtration system. Many cultivators use bags or bottles fitted with a filter—either plugged cotton or a specially designed filter disc that prevents the introduction of airborne contaminants. Often times, one to two days must pass until the mass naturally falls below 100° F. (38° C.), at which point inoculations can begin.

Super-pasteurization of supplemented oak sawdust substrates, although effective, often results in less total yield than from the same substrate sterilized. Comparative studies by Badham (1988) showed that there are no appreciable differences in yields of Shiitake between supplemented sawdust blocks subjected to *high pressure* autoclaving vs. *atmospheric* steam sterilization for the first flush. In comparing total yields, however, more mushrooms can be grown per pound of sawdust if pressure sterilization is employed. The greater yield from sterilized sawdust, according to Royse et al. (1985), is not due to the survival of contaminants, but a function of the rendering of the sawdust into a form more readily digestible to the Shiitake mycelium.\*

\* Those using the more rapidly decomposing hardwoods as a substrate base, such as alder, have not found yields on super-pasteurized sawdust to be depressed compared to sterilized sawdust. Moreover, the density of the wood and moisture content are major factors affecting heat penetration. The addition of buffers, calcium carbonate and calcium sulfate are recommended for the more acidic woods. For more information see Badham (1988) and Miller & Jong (1986).



Figure 140. Cutting a bag of pure sawdust spawn for use as inoculum into supplemented sawdust.

Pressurized steam essentially softens the sawdust.

### Inoculation of Supplemented Sawdust: Creating the Production Block

The best path for the inoculation of supplemented sawdust is via sawdust spawn. However, the direct path of grain spawn-to-supplemented sawdust is also successful, provided several precautions are taken. Inoculations of supplemented sawdust via grain spawn are prone to self-heating, a phenomenon leading to contamination. *This is especially true with Shiitake.* As supplemented sawdust is consumed by mycelium, exothermic reactions emerge at various rates. Regardless of the species, the incubating bags must be spaced apart to preclude thermogenesis. (Open wire shelves



Figure 141. Pouring sawdust spawn into bag of sterilized, supplemented sawdust.

**Three people can inoculate 400-500 bags in one shift by hand.**

Person	Duties	Experience Level
Lab Manager	Spawn Selector Primary Inoculator	+++
First Assistant	Sealer Bag Labeller Product Stream Coordinator	++
Second Assistant	Shaker (1/2 time) Bag Mover	+

are recommended over solid shelves.) Once inoculated, the internal temperatures of the bags soon climb more than 20° F. over the ambient air temperature of the laboratory. Once the 95-100° F. (35-38° C.) temperature threshold is surpassed, dormant thermophiles spring to life, threatening the mushroom mycelium's hold on the substrate. For cultivators in warm climates, these temperature spirals may be difficult to control.

Since the risk of contamination is greater with supplemented sawdust, each step must be executed with acute attention to detail. The lab personnel must work as a well-coordinated team. The slightest failure by any individual makes the efforts of others useless. The same general guidelines previously described for the inoculation of sterilized agar, grain, and sawdust media parallel the inoculation steps necessary for inoculating sawdust bran.

Automatic inoculation machines have been built in the attempt to eliminate the "human factor" in causing contamination during inoculation. I have yet to see a fully automatic spawning machine that out-performs a highly

skilled crew. When the human factor is removed from this process, a valuable channel of information is lost. The human factor steers the course of inoculation and allows quick response to every set of circumstances. Every unit of spawn is *sensed* for any sign of impurity or undesirability. The spawn manager develops a ken for choosing spawn based as much on intuition, as on appearance, fragrance, and mycelial integrity.

Inoculations by hand require that either gloves are worn or that hands are washed frequently. With repetition, manual dexterity skills develop, and success rates in inoculations improve dramatically. Answering the telephone, touching your eyes, picking up a scalpel off the floor, making contact with another person are causes for immediate remedial action.

Although one person can inoculate the sawdust bran bags by himself, a well coordinated team of three to four expedites the process with the shortest intervals of "down time" and the highest outflow of production. The process can be further accelerated by pre-marking bags, pre-shaking spawn, using

agitators to evenly disperse the spawn, gravity or belt conveyors, etc.

### **Steps and Duties for the Personnel Inoculating Supplemented Sawdust**

Before proceeding, the lab must be thoroughly cleaned after the autoclave is emptied. The enriched sawdust blocks are positioned in front of the laminar flow bench. Additional blocks are stacked on movable, push carts which can be quickly moved and unloaded in and out of the inoculation area. The laboratory personnel have prepared the inoculation site by supplying alcohol squirt bottles, paper towels, garbage bags, marking pens, and drinking water. If only a two-person lab crew is available, the duties of the Lab Manager and the First Assistant are often combined.

#### **Step I**

##### *Lab Manager*

Select pure spawn. Avoid any units of spawn showing the slightest disparity in growth. Be suspicious of spawn units adjacent to partially contaminated ones. Usually contamination outbreaks run through a series of consecutive inoculations, to greater and lesser degrees. Individual units of spawn that look pure but are neighbors to contaminated units should only be used as a last recourse. Shake the spawn, thoroughly breaking it up into its finest particles. Place the spawn immediately downstream from the bag sealer. Wipe your hands with 80% isopropanol (rubbing alcohol).

##### *First Assistant*

The First Assistant works with the Lab Manager in shaking the spawn, readying it for use.

##### *Second Assistant*

The Second Assistant positions the bags and begins pre-labelling. If using more than one strain or species, pre-labelling must be done carefully, lest confusion between strains occur.

#### **Step II**

##### *Lab Manager*

The Lab Manager holds a bag of sawdust spawn and, using a pair of aseptically cleaned scissors cuts at a 45 degree upward angle towards the opposite corner, cutting across the previous seal. (See Figure 140). This results in a "spout," facilitating the transfer of spawn from one bag to another. By holding a bottom corner with one hand, and raising the bag with the other hand, grasping above the newly created spout, the transferring of spawn from one bag to another container is simple and fast. (If inoculating supplemented sawdust with grain spawn, follow the techniques described on page 156 for Inoculating Sterilized Sawdust).

As the inoculations progress, care is taken not to touch the inside walls of the bags with your hands. The bags can be pulled apart by grasping the outside plastic, expanding the opening, so that sawdust spawn can be received without hindrance. At times the First Assistant may be called upon to make sure the bags are fully opened.

##### *First Assistant*

The First Assistant closes the bags on the pre-cleaned thermal bag sealer on the uppermost, opened portion. The sealer is activated (depending on type) and the panels of plastic meld together, capturing a volume of air in the process. Ideally, a "domed" bag can be created. (See Figure 125 and 129). Sometimes, multiple seals are necessary before full closure is achieved.

##### *Second Assistant*

As soon as the bag has been hermetically sealed, it is removed from the position behind the sealer and passed to the Second Assistant. The Second Assistant first determines if the bag has been sealed. By gently squeezing, leaks are detected by either the slow collapse of the bag, the sound of air escaping, or visual ob-

ervation. If the leak is due to a puncture, the hole is covered with plastic packaging tape. If the seal is imperfect, the bag is returned to the First Assistant for a second try at heat sealing. Once each bag has been properly sealed and assured of proper labelling, thorough shaking is in order. Using a combination of agitation and rotation, the sawdust spawn is mixed through the supplemented sawdust. The sawdust spawn has a lighter color than the supplemented sawdust and hence it is easy to see when the spawn has been evenly dispersed.

The Second Assistant gently slams the sealed, domed bag on a tabletop to close any open spaces, and increase the density of the mass. (In shaking, the mixture becomes quite loose.) The bag is positioned on a wire shelf where daily observations are made for the next few weeks. The bags are kept at least a finger-breadth apart. *These newly inoculated, incubating bags must not touch one another.*

Now that the duties of the three laboratory personnel are clearly defined, working in concert becomes the foremost priority. A well-organized laboratory team achieves a furious pace. Conversation is kept to a minimum. (The person doing the inoculations can't talk anyhow, except between sets of inoculations, lest his breath spread bacteria. Wearing a filter mask reduces this risk.) However, times arise when one or more of the three-person production flows is interrupted. During these down-times, counter-tops should be vacuumed and wiped clean with alcohol. Garbage can be consolidated. Finally, one's hands are washed prior to any more inoculation activity. The pace during the inoculation process should be both rhythmic and fast. Inoculations are purposely interrupted after every 50 or so bags so periodic cleaning can occur. Depending on the equipment, design of the facility, and experi-

ence of the laboratory personnel, better ways of organizing the labor during inoculations will naturally evolve. However, this method works well. Hundreds of bags can be inoculated during a single shift. Greater efficiency is realized if two or more sealers are employed simultaneously.

After inoculation, each bag can be shaken by hand. Larger farms place the bags onto a gravity conveyor leading to a multiple bag, automatic shaking machine. As the crew's performance improves with experience, block production soars into the thousands per shift. With each bag yielding \$ 10-50 + U.S., every doubling of production over a baseline level, realizes proportionally greater profits for the owners.

Once shaken the inoculated bags are placed on open wire shelves and spaced about 1 inch apart for incubation. Bags contacting one another are likely to contaminate with black pin or other thermophilic molds.

## Incubation of the Production Blocks

The first two weeks of incubation after inoculation are the most critical. If the supplemented sawdust is not fully colonized during that time period, contamination usually arises soon thereafter. Within several days of inoculation, out-gassing of volatile by-products causes a distinctly noticeable fragrance. As soon as the laboratory is entered, the atmosphere imparts a unique "odor signature." The smell is generally described as sweet, pleasant, and refreshing.

The incubation room should be maintained at 75° F. (24° C.) and have an ambient humidity between 30-50%. Since the internal temperatures of the incubating blocks are often 20° F. higher than ambient air temperatures, keeping



the incubation room warmer than recommended is likely to cause the internal incubation temperatures to rise to dangerous levels. Carbon dioxide levels within the laboratory should never exceed 1000 ppm, although 20,000-40,000 ppm of CO<sub>2</sub> is typical within the bags as they incubate. This steep slope of high CO<sub>2</sub> within the bag to the low CO<sub>2</sub> in the atmosphere of the laboratory is helpful in controlling the evolution of metabolic processes. Should the gradient be less severe, CO<sub>2</sub> levels can easily exceed 50,000 ppm within the incubating bags. At this and higher levels, mycelial growth lessens and contaminants are encouraged. To compensate, the laboratory air handling system must be adjusted for the proper mixing of fresh vs. recirculated air. (See Appendix II Designing a Laboratory)

Three days after inoculation the mycelium becomes clearly visible, often appearing as fuzzy spots of growth. Second shaking, although essential for insuring full colonization of grain spawn, is not usually advisable in the incubation of supplemented sawdust. If complete sterilization has not been achieved, second shaking can result in a contamination bloom. If one is certain that sterilization has been achieved, second shaking *helps* colonization, especially around Days 4-5.

Each species uniquely colonizes supplemented sawdust. Oyster mycelium is notoriously fast, as is Morel mycelium. "Good growth" can be generally described as *fans of mycelium rapidly radiating outwards from the points of inoculation. Growth is noticeable on a daily, and in some cases, on an hourly basis.* When the mycelium loses its finger-like outer edges, forming circular dials, or distinct zones of demarcation, this is often a sign that contaminants have been encountered, although they may not yet be visible. The behavior of the

mycelium constantly gives the spawn manager clues about the potential success of each run.

Large runs of supplemented sawdust are more likely to host minute pockets of unsterilized substrate than smaller ones. Should colonization be inhibited, encouraged by any number of factors—poor strain vigor, a dilute inoculation rate, elevated internal thermal or carbon dioxide levels—contaminants are to be expected. *This race between the mycelium and legions of competitors is a central theme operating throughout every stage of the cultivation process.*

### **Achieving Full Colonization on Supplemented Sawdust**

Prior to the mycelium densely colonizing the blocks with a thick and tenacious mycelial mat, the supplemented sawdust appears to be grown through with a fine, but not fully articulated, mycelial network. With most species, the once brown sawdust mixture takes on a grayish white appearance. With Shiitake mycelium, this is usually between Days 3-7. During this state, the mycelium has yet to reach its peak penetration through the substrate. Although the substrate has been captured as a geological niche, the mycelial network continues to grow furiously, exponentially increasing in its micro-netting capacity. The bags feel warm to the touch and carbon dioxide evolution peaks.

Within hours, a sudden transformation occurs: The once-gray appearance of the bags flush to snow-white. The fully articulated, thick mycelial network achieves a remarkable tenacity, holding fast onto the substrate. Now when each block is grasped, the substrate holds together without falling apart, feeling solid to the touch.

The blocks can be further incubated until needed, within certain time restraints. (Refer to

---

Chapter 21 for the particular time requirements of each species.) With a one-room laboratory, inoculations and incubation can occur in the same space. If a multi-room laboratory is being used, then the supplemented sawdust blocks are furthest downstream from the precious petri dish cultures. In fact, they should be nearest the door for ease of removal. Ideally, this sequence of prioritizing cultures should follow each step in the exponential expansion of the mycelial mass:

1. Petri dish cultures are furthest upstream, i.e. are given the highest priority.

2. Grain spawn is organized in rank, downstream from the cultures maintained on malt agar media. First Generation, Second Generation and Third Generation spawn are prioritized accordingly. Grain spawn, incubated in jars, is best stored at angles in vertical racks.

3. Sawdust spawn, being created from grain spawn, is next in line. Second generation sawdust spawn is kept next downstream

4. Supplemented sawdust blocks designed for mushroom cropping, along with any other units destined for fruiting or implantation outdoors, are incubated closest to the exit. (Please refer to Figure 387, Lay-out of a spawn laboratory.)

As the mycelium is expanded with each generation of cultures, contamination is increasingly likely. This specified flow pattern prevents reverse contamination of upstream cultures from those downstream.

Once the mycelium achieves the above-described "grip" on the supplemented sawdust, the nature of the mycelium changes entirely. The blocks cease to generate heat, and carbon dioxide evolution abruptly declines. With most species, the blocks no longer need to be treated so delicately. They can be moved to secondary storage rooms, even thrown through the air from one person to another. (A new sport!?) This state of "mycelial fortitude" greatly facili-

tates the handling process. The blocks should be moved out of the laboratory environment and either taken to a staging room for later distribution to the growing room or a dark, refrigeration room until needed. This resilient state persists until mushrooms form within the bags, either in response to environmental changes or not. Many strains of *Lentinula edodes* (Shiitake), *Hericium erinaceus* (Lion's Mane), *Grifola frondosa* (Hen-of-the-Woods), *Agrocybe aegerita* (Black Poplar Mushroom), and *Pleurotus spp.* produce volunteer crops of mushrooms within the bags as they incubate in the laboratory, without any environmental shift to stimulate them.

For many of the species listed in this book, volunteer fruitings begin three to six weeks after inoculation. Just prior to the formation of visible mushrooms, the topography of the mycelium changes. With Shiitake, "blistering" occurs. The smooth surface of the outer layers of mycelium, roughens, forming miniature mountains and valleys. (See Chapter 21.) With Lion's Mane (*Hericium erinaceus*), dense, star-like zones form. These are the immediate precursors to true primordia. If these ripe bags are not taken to the growing room in time, the newly forming mushrooms soon malform: most frequently with long stems and small caps. (These features are in response to high CO<sub>2</sub>, lack of light, or both.) The young mushrooms at this stage are truly embryonic and must be treated with the utmost care. The slightest damage to the developing primordia will be seen later—at the full maturity—as gross deformations: dimpled or incomplete caps, squirrely stems, etc. Shiitake are particularly fragile at this stage whereas Oyster mushrooms tend to return to a near-normal forms once exposed to the conducive climate of the growing room.

## Handling the Bags Post Full Colonization

Depending upon the species, three to six weeks pass before the bags are placed into the growing room. Before moving in the blocks, the growing room has been aseptically cleaned. After washing with bleach, I tightly close up the room after for 24 hours and turn off all fans. The residual chlorine becomes a disinfecting gas permeating throughout the room, effectively killing flies and reducing mold contaminants. A day after chlorine treatment, fans are activated to displace any residual gas before filling. Additional measures prior to bleaching include replacing old air ducting

with new, the changing of air filters, etc.

By spacing the bags at least 4-5 inches apart, the developing mushrooms mature without crowding. Sufficient air space around each block also limits mold growth. Galvanized, stainless steel and/or epoxy coated, wire mesh shelves are preferred over solid shelves. Wood shelves should not be used because they will eventually, no matter how well treated, become a site for mold growth. Farms which do use wood trays either chemically treat them with an anti-fungal preservative to retard mold growth or construct them from redwood or cedar. I know of no studies determining the transference of toxins from chemically treated trays into mushroom fruitbodies.



# Cultivating Gourmet Mushrooms on Agricultural Waste Products

**M**any wood decomposers can be grown on alternative substrates such as cereal straws, corn stalks, sugar cane bagasse, coffee pulp, banana fronds, seed hulls, and a wide variety of other agricultural waste products. Since sources for hardwood by-products are becoming scarce due to deforestation, alternative substrates are in increasing demand by mushroom cultivators. However, not all wood decomposers adapt readily to these wood-free substrates. New mushroom strains that perform well on these alternative substrates are being selectively developed.

The more hearty and adaptive *Pleurotus* species are the best examples of mushrooms which have evolved on wood, but readily produce on agricultural waste products. When these materials are supplemented with a high nitrogen additive (rice bran, for instance), simple pasteurization may not adequately treat the substrate, and sterilization is called for. (Without supplementation, pasteurization usually suffices.) Each cultivator must consider his unique circumstances—juxtaposing the available substrate components, species, facilities,

and market niches—in their overall system design.

Growing the Oyster Mushroom, *Pleurotus ostreatus*, on straw is less expensive than growing on sterilized sawdust. In contrast, Shiitake, *Lentinula edodes*, which barely produces on wheat straw is best grown on wood-based substrates.\* When both straw and sawdust are difficult to acquire, alternative substrates are called for. Mini-trials are encouraged before substantial resources are dedicated to any commercial enterprise. I encourage readers to formulate new blends of components which could lead to a breakthrough in gourmet and medicinal mushroom cultivation.

## Alternative Fruiting Formulas

Here is a basic wood-free formula for the cultivation of wood-decomposing mushrooms. A nitrogen supplement, in this case rice bran, is added to boost yields. As discussed, the substrate must be heat-treated by any one of a number of methods to affect sufficient sterilization.

### Alternative Fruiting Formulas

100 lbs. (45.5 kg.) ground corn cobs, peanut shells, chopped roughage from sugar cane bagasse, tea leaves, coffee banana, saguaro cactus, straw, etc.

10 lbs. (4.6 kg.) rice bran or approximately

2.5 lbs extracted soybean oil

4 lbs. (1.8 kg.) gypsum (calcium sulfate)

1 lb. (.45 kg.) calcium carbonate

100-140 lbs. (45-64 kg.) water or as required.

The amount of calcium carbonate can be altered to effectively raise pH, offsetting any inherent acidity. The components are mixed in dry form and wetted until a 70-75% moisture content is achieved. The mixture is loaded into

bags and immediately heat-treated. Should the bags sit overnight, and not autoclaved, contaminants proliferate, making the mixture unsuitable for mushroom cultivation.

The methods described here for the cultivation of mushrooms indoors on straw can be extrapolated for cultivating mushrooms on chopped cornstalks, sugar cane bagasse, and many other agricultural waste products. In contrast to wood wastes, which should be sterilized, I believe most unsupplemented agricultural by-products are better pasteurized using steam or hot water baths. Pasteurization typically occurs between 140-180° F. (60-82° C.) at atmospheric pressure (1 psi). Sterilization is by definition, above the boiling point of water, >212° F. (100° C.), and above atmospheric pressure, i.e. >1 psi. A hybrid treatment, which I call atmospheric sterilization or “super-pasteurization” calls for the exposure of substrates to prolonged, elevated temperatures exceeding 190° F. (88° C.) for at least 12 hours. (See Figure 137.) In any case, a carefully balanced aerobic environment must prevail throughout the incubation process or competitors will flourish.

Readily available, inexpensive, needing only a quick run through a shredder (and sometimes not even this), wheat straw is ideal for both the home and commercial cultivator. Straw is a “forgiving” substrate for the small to mid-size cultivator, accepting a limited number of contaminants and selectively favoring mushroom mycelium. Growing on straw is far less expensive than growing on sawdust. Many cottage growers enter the gourmet mushroom industry by first cultivating Oyster mushrooms on straw. Wheat, rye,

\* Several patents have been awarded in the cultivation of Shiitake on composted, wood-free substrates. Although fruitful, wood-based substrates are still preferred by most Shiitake cultivators.

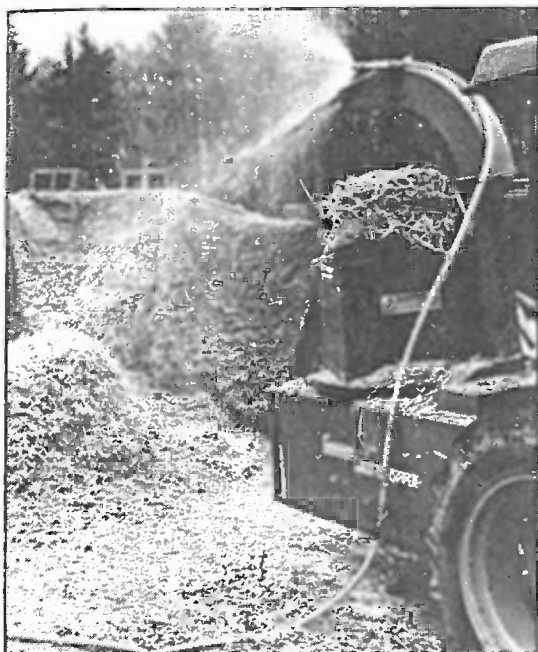

Figure 142. Shredding straw.

rice, oat and sorghum straws are the best. Hay, resplendent with abundant bunches of seed kernels, should not be used as the grain kernels tend to contaminate. However, limited numbers of grain kernels generally boost yields. Royse (1988) found that yields of Oyster mushrooms from wheat straw are enhanced by the addition of 20% alfalfa without increasing the risk of contamination. Alfalfa, by itself, is “too hot” to use because of its elevated nitrogen content. Straw supports all the gourmet Oyster mushrooms, including *Pleurotus citrinopileatus*, *P. cystidiosus*, *P. djamor*, *P. eryngii*, *P. euosmus*, *P. ostreatus* and *P. pulmonarius*. Other mushrooms, King Stropharia (*Stropharia rugoso-annulata*), Shaggy Manes (*Coprinus comatus*), the Paddy Straw (*Volvariella volvacea*), and Button (*Agaricus* spp.) mushrooms also thrive on straw-based substrates, often benefiting from modest supple-



Figure 143. A simple and easy method for pasteurizing straw (and other bulk materials). The drum is filled with water and heated with the propane burner at 160° F. (71° C.) for 1-2 hours.

mentation. The specifics for cultivation of each of these species are discussed further on, in Chapter 21.

## Heat Treating the Bulk Substrate

Bulk substrates like straw are generally pasteurized (as opposed to sterilized) and upon cooling, inoculated with grain spawn. Pasteurization selectively kills off populations of temperature-sensitive micro-organisms. The population left intact presents little competition to the mushroom mycelium for approximately two weeks, giving ample opportunity for the mushroom mycelium to colonize. If not colonized within two weeks, the straw naturally contaminates with other fungi, irrespective of the degree of pasteuriza-

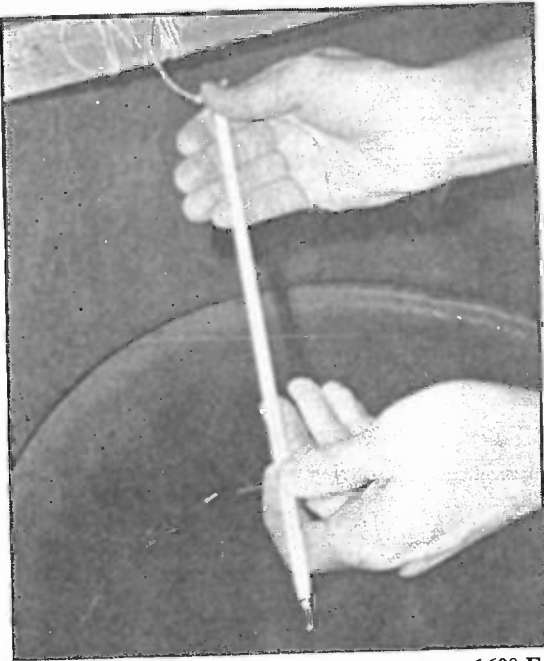

Figure 144. Monitoring water temperature. 160° F. (71° C.) is required for submerged fermentation.

tion. Straw is first chopped into 1" to 4" lengths and can be prepared via several methods.

### The Hot Water Bath Method: Submerged Pasteurization

The first method is the hot water bath. Straw is stuffed into a wire basket and submerged in a cauldron of 160-180° F. (71-82° C.) water for 1 hour\*. The cauldron is usually heated from underneath by a portable propane gas burner. The straw basket is forcibly pushed down into the steaming water and held in place by whatever means necessary. A probe thermometer, at least 12 inches in length, is inserted deep into the brothing mass, with string attached for convenient retrieval. The straw is submerged for at least one hour and no longer than two.

\* Stainless steel 55 gallon drums from the food/fermentation industry are preferred. If stainless steel drums are unavailable, only those designed for food storage/processing should be used.

Upon removing, the straw is well drained and laid out in a shallow layer onto cleaned surfaces (such as a counter-top) to rapidly cool. Most cultivators broadcast grain spawn over the straw by hand. Gloves *should* be worn but often are not, and yet success is the norm. In either case, the hands are thoroughly and periodically washed, every 15 minutes, to limit cross-contamination. The spawn and straw are then mixed thoroughly together and placed directly into bags, trays, columns, wire racks, or similarly suitable containers.

Another basket of chopped straw can be immersed into the still-hot water from the previous batch. However, after two soakings, the hot water must be discarded. The discolored water, often referred to as "straw tea", becomes toxic to the mushroom mycelium after the third soaking, retarding or preventing further mycelial growth. Interestingly, this tea is toxic to most vegetation, and could be used

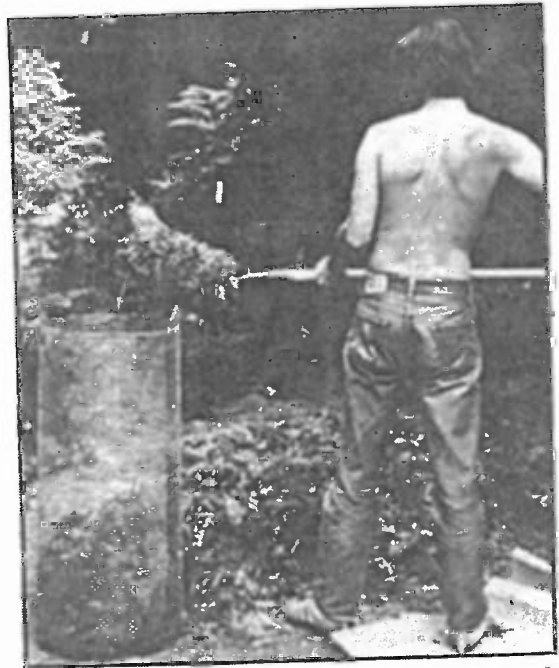

Figure 145. Straw is stuffed into a wire basket and then placed into the hot water.





Figure 146. A brick keeps the straw submerged during pasteurization.

as a natural herbicide.

### The "Phase II" Chamber: Steam Pasteurization

A second method calls for the placement of straw in a highly-insulated room into which steam is injected. This room is known as the Phase II Chamber. Before the straw is loaded into the Phase II chamber, it must be moistened. This can be done simply by spreading the chopped straw over a large surface area, a cement slab or plastic tarpaulin to a depth no greater than 12 inches. Water is sprayed on the straw via sprinklers over a two to four day period. The straw is turned every day to expose dry zones to the sprinkling water. After several turns, the straw becomes homogeneous in its water content, approaching 75% moisture, and is reduced to about 1/2 of its original volume. Short stacking the straw is not intended to ac-



Figure 147. After 1-2 hours of submerged pasteurization, the basket is lifted out. After draining excess water, the straw cools. Grain or sawdust spawn is broadcasted over the surface and mixed throughout the straw.

complish composting, but rather a way of tendering the straw fiber, especially the waxy, outer cuticle. In contrast to composting, the straw is not allowed to self-heat. Once evenly moistened, the straw is now ready for loading into the steam chamber.

An alternative method calls for the construction of a large vat into which straw is dunked. This tank is usually fitted with high pressure water jets and rotating mixing blades to assure full moisture penetration into the straw. If given sufficient agitation, finely chopped straw gains 75% moisture in the matter of minutes. Once moistened, the straw is loaded directly into the Phase II chamber.

One ton of wheat straw, chopped and soaked, occupies approximately 250 cubic feet

of space, equivalent to 10 ft. x 10 ft. x 2.5 ft. This figure is helpful in sizing a pasteurization chamber. An additional 25% allowance should be made for variation in the chop size of straw, air plenums, and handling needs. Five dry tons of wheat straw functionally fills a thousand square foot growing room. Most growers fill growing rooms to no more than 1/4th of total air volume. I prefer to fill to only 1/8th of capacity. This means that for every 8 air spaces, 1 space is occupied by substrate. (In other words, the ratio of air-to-substrate space is 7:1).

The classic Phase II room has a raised false floor, screened several inches above the true floor upon which steam pipes are situated. (See Figures 148–150). The walls and ceiling are well insulated. The interior panels are made of heat resistant, water-proof materials. Many convert shipping containers used to ferry cargo on ships into Phase II chambers. Others custom build their own steam rooms. Another important feature is a floor drain fitted with a gate valve. This valve prevents contamination from being

drawn in during and after pasteurization.

Boilers provide live steam, dispersed through the pipes, and into the straw, which can be filled to a depth as great as 8 ft. The greater the depth, the longer heat takes to penetrate to the center. Heat penetration can be enhanced with high-pressure blowers. Multiple thermometers are inserted in at least three, various locations: low (within 4-6 inches), midway, and high (within 12-24 inches of the top surface). These temperature probes should be monitored periodically to gather data for the generation of a pasteurization profile specific to each run. Over time, the temperature points of each successful batch are accumulated for establishing a baseline for future operations.

When steam is injected, the outer edges of the straw mass heat up first. An outer shell of high temperature forms, and over time increasingly enlarges towards the center. Early on in the Phase II process, three thermometers can read a range from room temperature to 160° F. (71° C.) simultaneously. This temperature differential must be monitored carefully. The

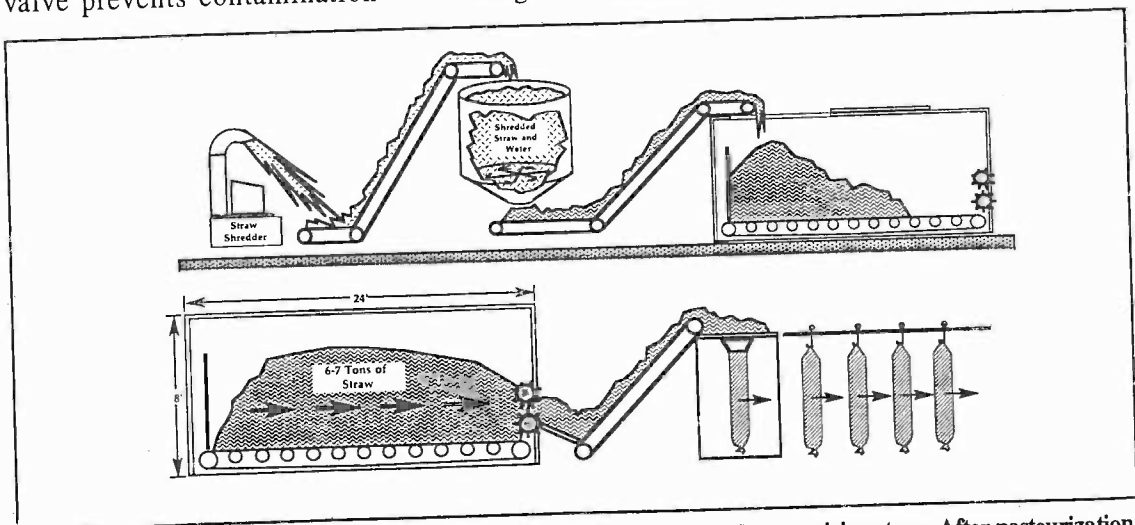

Figure 148. Profile of an automated bulk processing system for soaking and pasteurizing straw. After pasteurization, the steamed mass is pulled via a netted floor into two outwardly rotating, teathed cylinders which throw the straw onto conveyors. In this case columns are filled, although trays or other fruiting vessels could just as well be used.

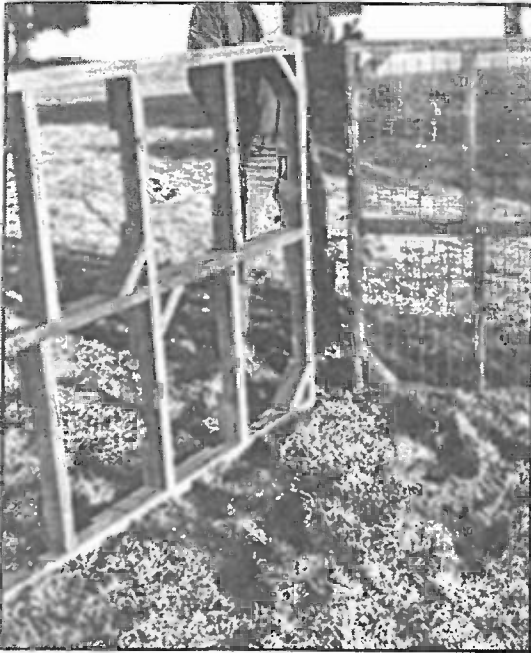

Figure 149. Newly constructed, screened floor racks which allow the passage of steam underneath the mass of bulk material being pasteurized.

centers of densely packed Phase II steam chambers remain below 100° F. (38° C.) for several hours, lagging behind the hot outer shell, and suddenly race upwards. If steam output from the boilers is not reduced in time, the entire mass continues to heat at an uncontrollable rate. Without the cold core, which in effect is a heat sink, to deflect the spiralling increase in temperature, thermal momentum continues for an hour or two beyond the time steam injection is shut off. The minimum recommended time for steam pasteurization is *two hours above 160° F. (71° C.)*.

A common oversight in steaming a mass of straw or compost is the failure to chart, every 30 minutes, the temperature profile of the mass. By measuring and charting, trend analysis is possible. If the climb in temperature is not anticipated, and reduced at the right time, the

thermal momentum of the hot outer shell not only overwhelms the ever-shrinking cold core, but causes the entire mass to skyrocket to 200°+ F. (93° C.), a temperature above which disaster awaits. Above this temperature plateau, non-competitive, beneficial organisms are killed, and the substrate becomes an open habitat for many competitors which would otherwise be held in abeyance.

When the steam output from the boiler is turned off, the Phase II box should be immediately positive-pressurized with contaminant-free air. By forcing air through a HEPA filter and ducting the air directly into the Phase II chamber, contaminants are prevented from being sucked in as the mass cools. For a steam box measuring 10 ft. x 10 ft. x 10 ft., a 1/8 HP blower pushing 200 CFM through a 12 in. x 12 in. x 6 in. HEPA filter (99.99 % @ .3 $\mu$ ) adequately positive-pressur-

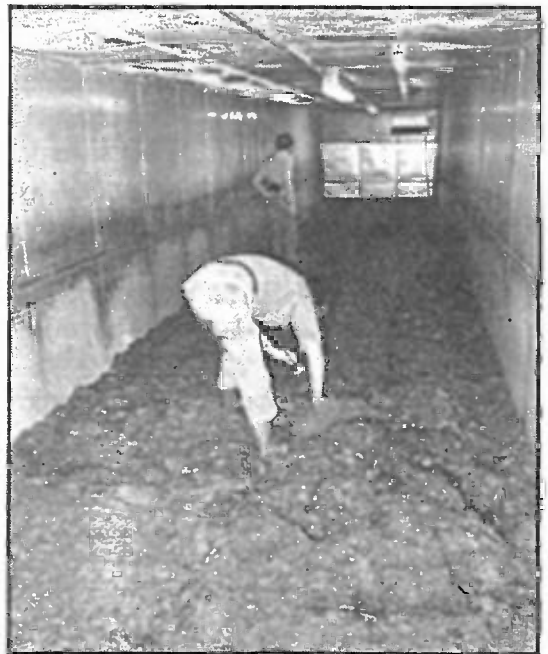

Figure 150. Inside a large Phase II chamber.

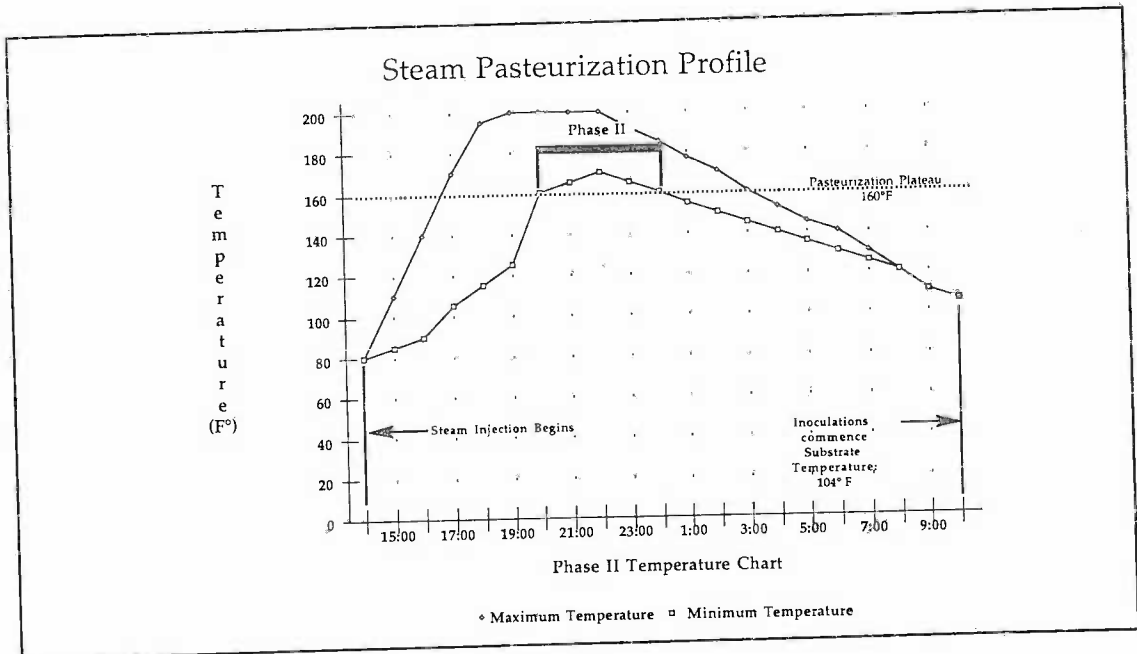

Figure 151. Chart: Temperature Profile of a Phase II Run.

izes the chamber. (Larger Phase II rooms will require correspondingly higher pressure fans able to push air over 2-4 inches of static pressure.) The substrate mass slowly cools in 12-24 hours to temperatures tolerable for inoculation, generally below 105° F. (38° C.).

Before the pasteurization chamber is opened, the inoculation area is intensively cleaned with a 10% bleach solution.\* To aid the cleaning process, venturi siphon mixers are ideal for drawing bleach directly into a hose line at the faucet connection. Conveyor belts, counter tops, funnels, ceilings, and walls are all cleansed with torrents of chlorinated water. Spraying down the room with such a solution is colloquially termed "bleach bombing" in the industry.

\* Most brand name bleaches have 5.25% sodium hypochlorite. One tablespoon of bleach in a gallon of water is roughly equivalent to 200 ppm chlorine. A cup of bleach per gallon of water is equivalent to 3200 ppm. Most mushroom mycelia are harmed above 200 ppm of chlorine.

Protective clothing is advised for the sanitation personnel.

Methods vary for the unloading of the Phase II chamber. Some remove the straw by hand with clean pitch-forks and throw the straw onto stainless-steel tables whereupon the inoculation occurs. Conveyors are favored for substrate handling by many growers. The largest Phase II chambers utilize a netted or "walking" floor which pulls the substrate mass into two outwardly rotating, horizontally positioned, teathed cylinders. (See Figure 148). As the substrate mass is forced into the space between the two outwardly rotating, spiked cylinders, the straw is separated and ejected onto a depressed platform in whose center is a funnel or ramp that leads to conveyors. (Warning: the danger of personal injury here at this juncture is notorious. Special precautions must be implemented to prevent accidents.) After the straw is thrown into the conveyor belt, grain

spawn is gravity fed or hand broadcasted onto the straw as it is being ferried away. Foot activated switches are helpful in controlling the off-loading of the substrate from the Phase II box with the conveyor.

When spawn is placed directly upon the surface of pasteurized straw, mixing is strongly advised. Cement and soil mixers, specially adapted funnels, ribbon blenders, and "Archimedes screws" suffice. If the spawn is laid upon straw and not mixed through, growth layers form resulting in uneven colonization. The advantage of removing the straw and inoculating by hand is that the process can be interrupted and recurrent cleaning can occur. By intermittently disinfecting, cross-contamination can be prevented. With automated, continuous loop systems, the likelihood that contamination can travel throughout the facility unchecked is greater. Special attention to detailed disinfection is necessary with these systems to prevent disastrous results should pasteurization be incomplete. Once spawn has been sown throughout the straw, the inoculated substrate is placed directly into the "fruiting" containers, usually columns, trays, or bags. Each container must be vented so the mycelium can respire as it colonizes the substrate.

### **Alternative Methods for Rendering Straw & other Bulk Substrates for Mushroom Cultivation**

Several inexpensive, alternative methods can be used for treating straw (and other bulk materials) that do not involve heat treatment. The first three are chemical; the last is biological. Surely other alternative methods will be developed as imaginative entrepreneurs experiment. By sequencing a substrate through a

combination of biological and chemical treatments, heat pasteurization can be entirely avoided. Small pilot-scale experimentation is strongly encouraged before cultivators attempt these techniques commercially. The future use of such methods is promising.

#### **The Hydrated Lime Bath Method**

Hydrated lime (calcium hydroxide) is extremely alkaline and water soluble. By immersing straw into water baths high in hydrated lime, competitor fungi and bacteria are largely rendered inactive from the drastic change in pH. The preparation is quite simple.

Two to four lbs. of lime is added for every 50 gallons of water. (Since a gallon of water weighs 8.3 lbs. this ratio is equivalent to 2-4 lbs. lime /415 lbs. water or about .5-1.0%) The pH of the water skyrockets to 9.5 or higher. Once dissolved, chopped straw is immersed into this highly alkaline bath. Under these caustic conditions, pH-sensitive microorganisms soon die. Subsequent to an overnight soaking, the water is drained and discarded. (Note that this highly alkaline water kills many plants and should be prevented from entering any sensitive ecosystem or watershed.) The straw is then drained and inoculated using standard methods. It is not unusual for the straw to achieve a pH of 8.5 or higher after soaking. Oyster mushroom mycelia can tolerate this alkaline environment better than most competitors. After three or four days of initial growth, pH slowly falls as the mycelium races through the straw, secreting acids and enzymes. One week after inoculation the straw should be fully colonized. If colonization is not complete within 7-10 days, competitors usually arise. Optimizing the parameters for the species being cultivated greatly influences the success or failure of this simple method. Please

consider that the starting pH of make-up water affects the final outcome. Each cultivator must compensate accordingly.

### **The Bleach Bath Method**

Similar to the hydrated lime method, but household bleach (5.25% sodium hypochlorite) is used as a disinfectant. I recommend adding 5-6 cups of household bleach to 50 gallons of water. A basketful of chopped wheat straw is immersed. The straw is kept submerged for a minimum of 4 and no more than 12 hours. The bleach leachate is drained off. The straw is immediately inoculated. Should colonization not be complete within two weeks, contaminants naturally occur. Cultivators should be careful where the toxic leachate is drained.

### **The Detergent Bath Method**

This method simply utilizes biodegradable detergents containing fatty oils to treat bulk substrates. Coupled with surfactants which allow thorough penetration, these detergents kill a majority of the contaminants competitive to mushroom mycelium. The substrate is submerged into and washed with a detergent solution. The environmentally benign waste water is discarded, leaving the substrate ready for inoculation. Recently, many environmentally safe soaps have been developed, especially in Europe. Cultivators are encouraged to experiment to match the best detergents to their substrate materials. Here again, the goal is to create a process that is both simple and applicable for small and large scale cultivators.

### **The Yeast Fermentation Method**

The fourth alternative method for rendering straw is biological. Straw can be biologically treated using yeast cultures, specifically strains of beer yeast, *Saccharomyces cerevisiae*. This method, by itself, is not as effective as those previ-

ously described, but has achieved limited success.

First a strain of beer yeast is propagated in 50 gallons (200 liters) warm water to which malt sugar has also been added. Recommended rates vary. Usually a 1-5% sugar broth is concocted. Fermentation proceeds for two to three days undisturbed in a sealed drum at room temperature (75° F., 24° C.). Another yeast culture can be introduced for secondary, booster fermentation that lasts for another 24 hours. After this period of fermentation, chopped straw is then forcibly submerged into the yeast broth for no more than 48 hours. Not only do these yeasts multiply, absorbing readily available nutrients, which can then be consumed by the mushroom mycelium, but metabolites such as alcohol and anti-bacterial by-products are generated in the process, killing competitors. Upon draining, the straw is inoculated using standard procedures.

Another method of submerged fermentation uses the natural resident microflora from the bulk substrate. After 3-4 days of room temperature fermentation, a microbial soup of great biological complexity evolves. The broth is now discarded and the substrate is inoculated. Although highly odoriferous for the first two days, the offensive smell soon disappears and is replaced by the sweet fragrance of actively growing mycelium. I hesitate to recommend it over the other procedures described here.

The outcome of any one of these methods greatly depends on the cleanliness of the straw being used, the water quality, the spawn rate, and the aerobic state of the substrate during colonization. These methods generally do not result in the high consistency of success (> 95%) typical with heat pasteurization techniques. However, with refinement, these simple and cheap alternatives may prove practical wherever steam is unavailable.

## Cropping Containers

Choosing the “best” type of cropping container depends upon a number of variables: the mushroom species; the cultivator; and the equipment/facility at hand. White Button growers typically grow in trays made of either wood or metal. Facilities designed for growing Button mushrooms (*Agaricus* species) encounter many difficulties in their attempts to adapt to the cultivation of the so-called exotic mushrooms. For instance, most Oyster mushrooms have evolved on the vertical surfaces of trees, and readily form eccentrically attached stems. These species, with few exceptions, perform poorly on the horizontal trays designed for the *Agaricus* industry. Because Oyster mushrooms require healthy exposure to light, the darkened, dense-packed tray system gives rise to unnatural-looking, trumpet-shaped Oyster mushrooms. This is not to say that Oyster strains can not be grown *en masse* in trays. However, many Oyster strains perform better, in my opinion, in columns, vertical racks, or bags. After taking into account all the variables, cultivators must decide for themselves the best marriage between species and cropping container. Please consult Chapter 21 for specific recommendations for the cultivation of each species.

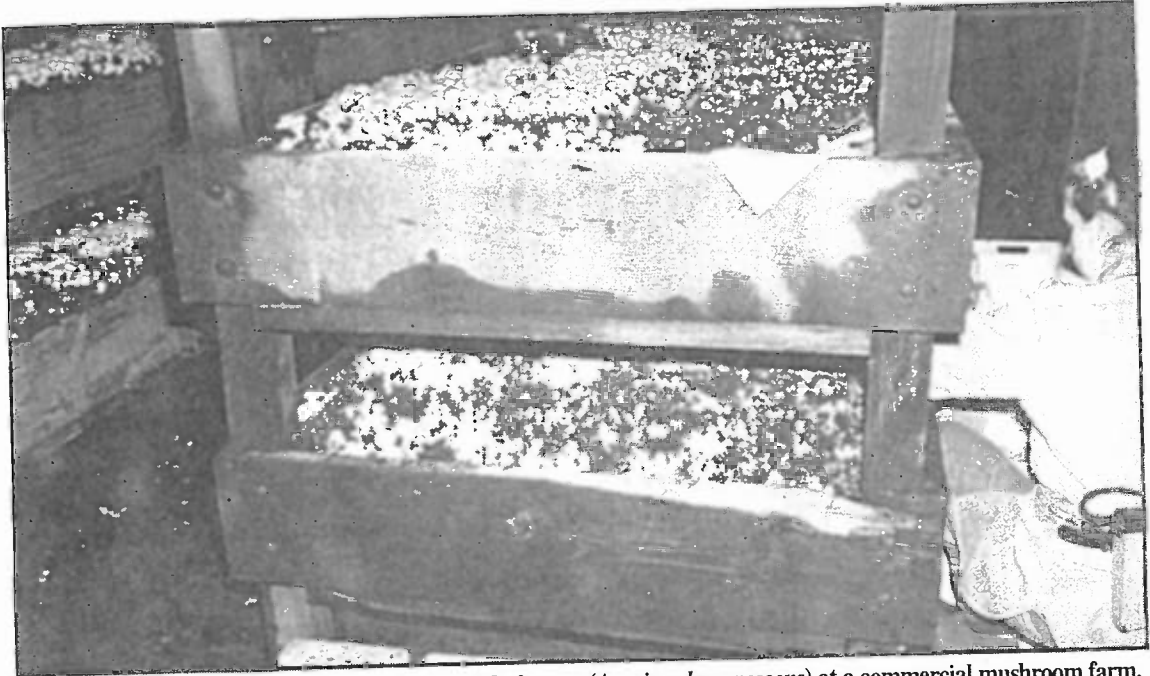

Figure 152. Wooden tray culture of the Button Mushroom (*Agaricus brunnescens*) at a commercial mushroom farm.

## Tray Culture

Growing mushrooms in trays is the traditional method of cropping, first developed by the Button mushroom (*Agaricus*) industry. Trays range in size from small 2 ft. x 3 ft. x 6 in. deep which can be handled by one person to trays 6 ft. x 10 ft. x 12 in. deep which are usually moved into place by electric or propane-powered forklifts. For years, trays have been constructed of treated or rot-resistant wood. More recently, polycarbonate and steel trays have been introduced with obvious advantages. Both types are designed to stack upon each other without additional structural supports.

Trays allow for the dense filling of growing rooms (up to 25% of the volume) and because *Agaricus brunnescens*, the Button Mushroom, is not photosensitive, no provisions are made for the equal illumination of the beds' surfaces. The main advantage of tray culture is in the han-

dling of substrate mass-filling, transporting, cropping and dumping. The Dutch are currently using tray culture for the cultivation of Button, Shiitake, Oyster and other mushroom species.

Tray culture easily accepts a casing layer. Casing layers are usually composed of peat moss, buffered with calcium carbonate, and applied directly to the surface of a myceliated substrate. Button mushroom production excels from the application of a casing layer, whereas it is debatable whether yields from the wood decomposers are substantially affected. Those using trays and *not* applying a casing must take extra precaution to ensure the necessary microclimate for primordia formation. This can be accomplished by covering the trays with either a perforated layer of plastic or breathable, anti-condensate films. The plastic is stripped off, depending upon the species, at the time of, or soon after, primordia formation. Fog-like envi-



ronments typically ensue until the primordia have firmly set.

In North America, tray culture for Oyster mushrooms was perfected by Davel Brooke-Webster (1987). This method utilizes a perforated plastic covering over the surface of trays. Since many Button mushroom farms are centered around tray technology, the replacement of the casing layer with a sheet of perforated plastic allows the cultivation of both species at the same facility. Holes (1-2 inches dia. ) are punched evenly through a 8 ft. roll of plastic, before application. The plastic sheeting is stretched over the trays, directly after inoculation of Oyster spawn into pasteurized wheat straw. The plastic barrier prevents 98% of the evaporation that would otherwise occur had the inoculated straw remained exposed. Even with the plastic covering, humidity within the growing room should remain relatively high so that the straw exposed to the air directly below the

holes does not "pan" or die back. A sure sign that the growing room humidity is too low is when brown zones of dry straw form around each puncture site while the remainder of the substrate is white with mycelium.

An advantage of the Brooke-Webster technique is that: bouquets of equal weight are produced simultaneously on the same trays so widely used by the Button mushroom (*Agaricus brunnescens*) industry. A disadvantage of tray culture is that equal exposure of light over the surface of each tray, when tightly stacked upon one another, is difficult. (When providing light to tightly packed trays, the fixtures are usually mounted on the underside of the tray immediately above the fruiting surface. Most cultivators remove the heat-generating ballasts to a remote location and re-capture the heat into their air circulation system. ) When lighting is insufficient in Oyster mushroom cultivation, stems elongate while caps remain

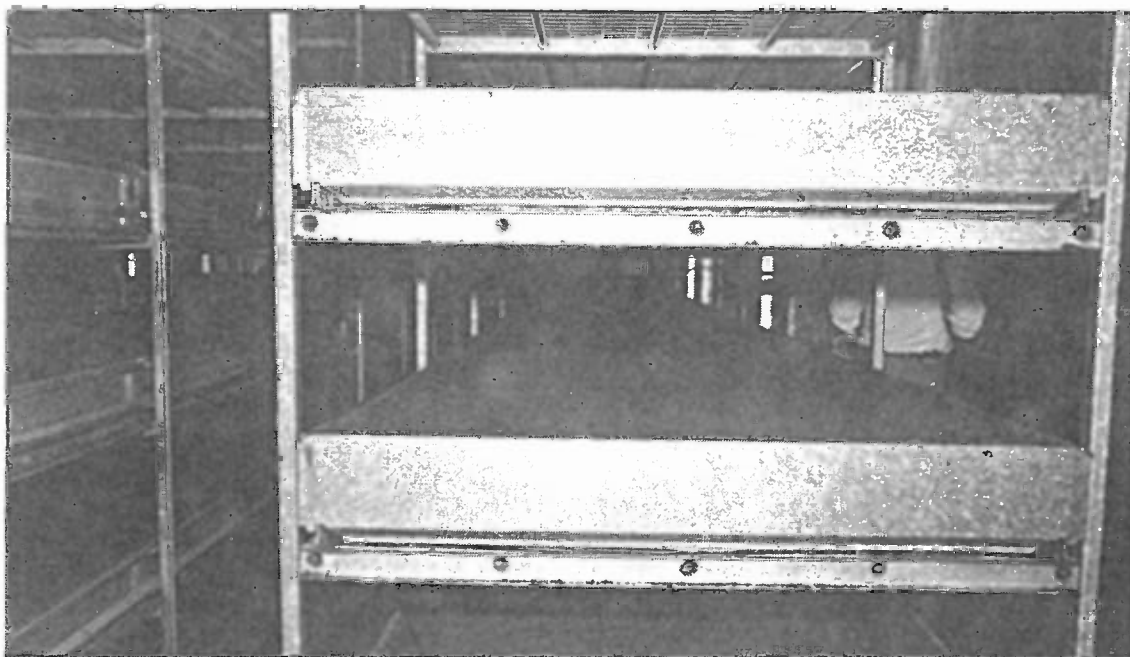

Figure 153. Dutch-made, rust resistant, metal trays used for the cultivation of the Button mushroom.

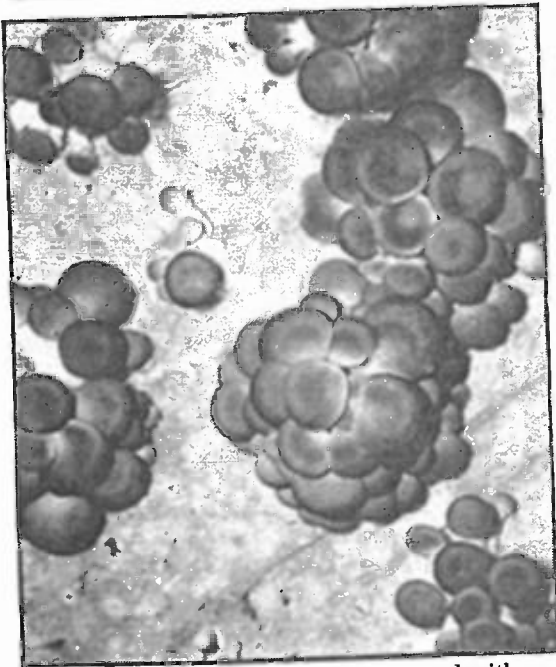

Figure 154–157. Horizontal trays covered with perforated plastic allow for the simultaneous emergence of Oyster mushroom bouquets from pasteurized wheat straw. In this case the variety being cultivated is the “sajor-caju” variety of *Pleurotus pulmonarius*. This technique was first developed by Canadian Davel Brooke-Webster.

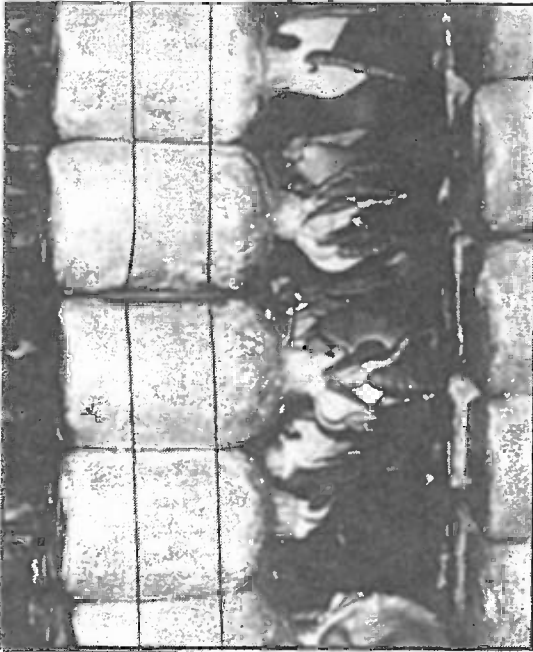

Figure 158. The Phoenix Oyster, *Pleurotus pulmonarius* fruiting from a wall formation of stacked bags.

underdeveloped, causing abnormal, fluted or trumpet shaped mushrooms.

The key to the success of this method lies with strains which form bouquets of mushrooms *site-specifically* at the holes in the plastic. Ideally, primordial clusters hosting multiple mushrooms form at each locus. (See Chapter 14. Features for Evaluating & Selecting a Mushroom Strain. )

## Vertical Wall Culture

In the progression of techniques, the *Agaricus* tray has been modified for growing Oyster mushrooms by turning it vertically so mushrooms could fruit out both faces. Usually these vertical surfaces are screened with tight wire or plastic mesh. Perforated plastic positioned between the substrate and the wire mesh allows the formation and development of mush-

rooms while retaining moisture. Alternately, a plastic curtain is used to envelope the container until the time of fruiting.

Racks having a breadth of 12-16 inches support full flushes and generally do not become anaerobic near the core, a problem seen when racks are 20 inches and more in breadth. If properly designed, individual 4 ft. x 4 ft. to 4 ft. x 8 ft. rack frames can be stacked upon each other in the construction of continuous mushroom walls. With one side of the frame hinged for opening, filling is made easy.

Another variation of wall culture is the building of walls by stacking polypropylene bags, sideways, on top of one another. Only the ends of the bags have an opening, causing mushrooms to form on the exposed outer surface of the constructed wall. Here, forming the bags into a square shape at the time of inoculation facilitates wall construction.



Figure 159. Slanted wall culture of Shiitake, constructed of stacked sawdust blocks.

## Slanted Wall or "A" Frame Culture

Slanted walls are constructed by stacking bags of inoculated substrate to build sloped faces. An advantage of the slanted wall is that a higher density of fill can be achieved within a given growing room space and harvesting is easier. A disadvantage is that mushrooms are limited to forming on only one plane- the outwardly exposed surface. In comparison, blocks that are spaced apart give rise to fruitings on 5 planes: the four sides *and* the top, a response seen especially with Shiitake and Oyster mushrooms.

Many cultivators find that a wall composed of individually wrapped blocks limits cross-contamination from infected units. Isolation of the blocks, or for that matter any fruiting container, has distinct advantages, both in terms of yield enhancement and contamination containment.

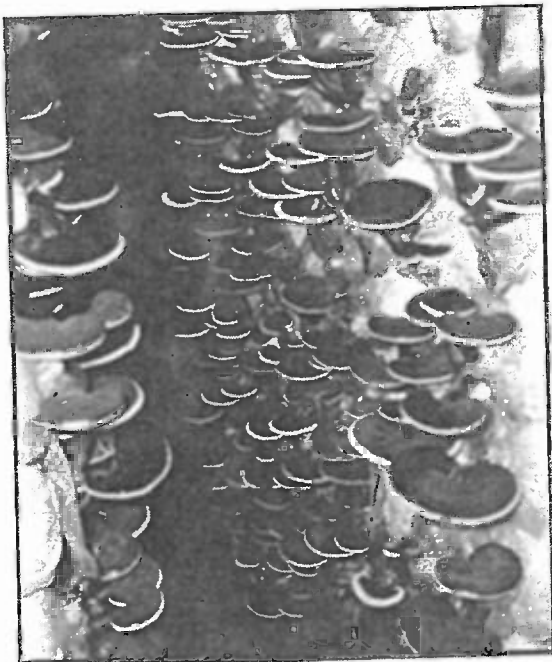

Figure 160. Black Reishi, *Ganoderma lucidum*, fruiting from wall formation of stacked bags.

## Bag Culture

In the search for inexpensive, portable, and disposable containers, plastic bags have become the logical choice. High temperature-tolerant polypropylene bags are primarily used for processing wood-based substrates which require higher temperature treatment than the cereal straws. Once cooled and inoculated, sterilized substrates are usually filled directly into heat sensitive polyethylene bags. Mushrooms fruit from the top or sides.

For the cultivation of most wood decomposers, a biodegradable, heat-tolerant, and breathable plastic for bag culture is sorely needed. "Cellophane", a wood cellulose-based plastic-like material used commonly in the mid 1900's, has some of these features (heat tolerance, gas porosity), but lacks durability. Despite this shortfall, one of the most appealing aspects



Figure 161. A white Oyster mushroom, *Pleurotus ostreatus*, fruiting from custom-made plastic grid-frame.



Figure 162. The hinged wall-frame—two trays latched together in the center. Mushrooms fruit out both sides. (Frame has been turned 90 degrees on side for photograph.)

of cellophane is that mushroom mycelium digests it in the course of its use. With mushrooms having such great potential for recycling wastes, it is ironic that non-recyclable plastics fill so critical a need amongst cultivators. Some ingenious re-structuring of cellulose could satisfy this increasing market for the environmentally sensitive.

Bag culture first became popular for the Button mushroom industry and is still used to this day. Inoculated compost is filled into and bags topped with a soil-like casing layer. (See Figure 165.) Individual bags are grouped on horizontal shelves. By preventing contact between the mycelium and the wooden shelves, contamination, especially from the wood-loving *Trichoderma* and *Botrytis* molds, is minimized.

Many growers favor plastic bags for their

ease of use. When holes are punched through the plastic, mushrooms emerge soon thereafter. Opaque, black bags encourage photosensitive strains of mushrooms to form only where the holes allow light exposure. Clear bags stimulate maximum populations of mushroom primordia but often times primordia form all over. Cultivators must remove the appressing plastic or selectively release colonies of primordia with sharp blades to insure crop maturity. However, many cultivators overcome this problem by using select Oyster strains that localize primordial clusters at exactly the puncture sites. By punching dozens of holes with stainless steel, four-bladed, arrowheads, large bouquets of mushrooms are encouraged to form. From the force of the enlarging mushrooms, the flaps are pushed opened. This method has many advantages and is highly recommended.

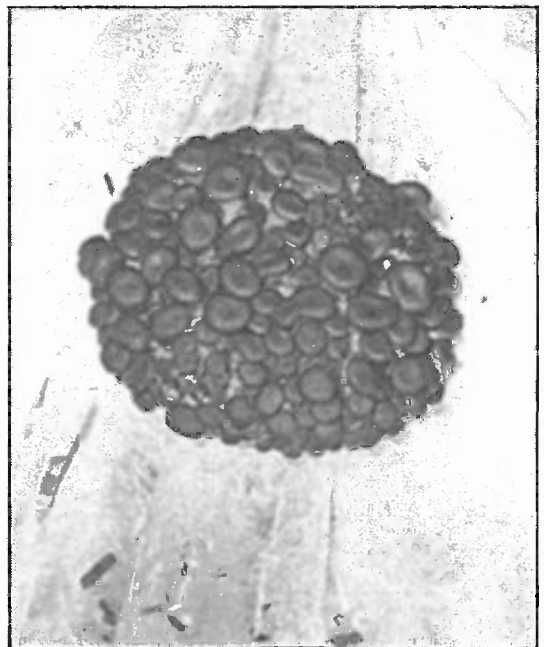

Figure 163. Primordial cluster of Oyster mushroom emerging through hole in plastic.

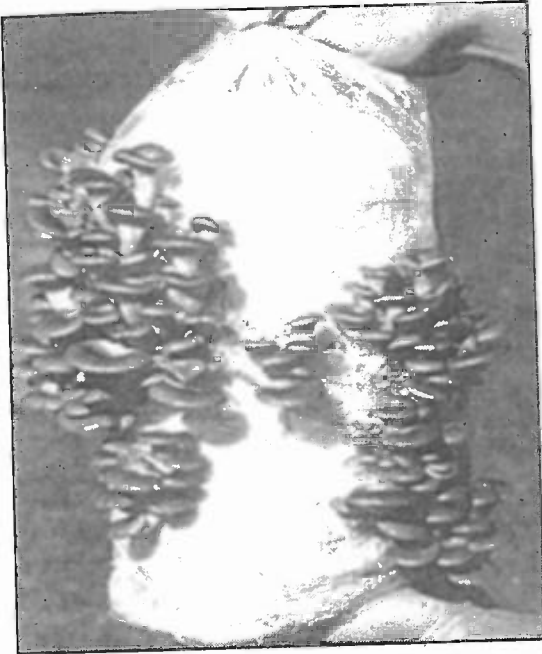

Figure 164. Oyster mushrooms fruiting from bag filled with wheat straw. This bag is sold by Fungi Perfecti as a mushroom kit.

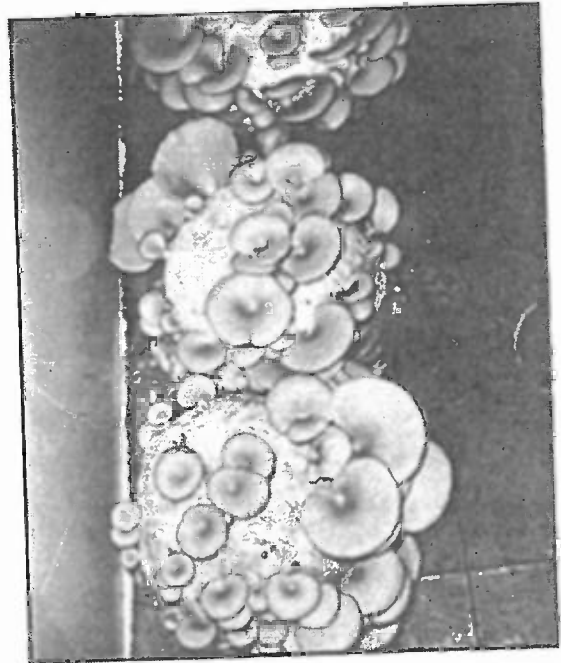

Figure 166. Bag culture of the Oyster mushroom (*Pleurotus ostreatus*).



Figure 165. Bag culture of the Button mushroom (*Agaricus brunnescens*).

### Column Culture

Growing Oyster mushrooms in columns gives rise to natural-looking fruitbodies. Having evolved on the vertical surfaces of hardwood trees, Oyster mushrooms with their off-centered stems, grow out horizontally at first, turn, and grow upright at maturity. \* This often results in the formation of highly desirable clusters, or "bouquets," of Oyster mushrooms. The advantages of cropping clusters from columns are that many young mushrooms form from a common site, allowing 1/4 to 1 lb. clusters to be picked with no further need for trimming, yields of succulent young mushrooms are maximized while spore load is minimized, harvesting is far faster than picking mushrooms individually, and the clusters store far better under refrigeration than

\* This response-to grow against gravity-is called "negative geotropism". See Badham (1985).

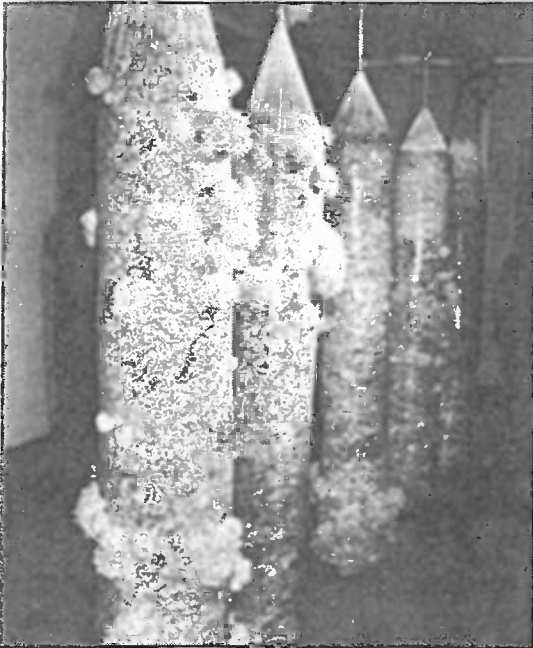

Figure 167. Bouquets of Golden Oyster mushrooms (*Pleurotus citrinopileatus*) fruiting from columns of pasteurized-wheat straw.

individual mushrooms.

Automated column-packing machines have been developed and tested in North America and Europe with varied results. Typically the machines rely on an auger or “Archimedes screw” which forces the straw through a cylinder with considerable force. Straw can be pasteurized, cooled, and inoculated along a single production line. Columns are packed, usually horizontally, in a sleeve which can be removed for the vertical placement of the column in the growing room. Several inventive engineers-turned-mushroom growers are currently developing production systems based on this concept. For many, separating each activity—pasteurization, inoculation, filling, and

\*\* Readers should be note that many suppliers sell ducting in “lay-flat” diameter, which is actually 1/2 of circumference. Simply divide the “lay-flat” measurement by 1.6 for true, inflated diameter.

positioning—simplifies the process and prevents cross-contamination.

Vertical cylinders can be made of a variety of materials. The least expensive is the flexible polyethylene ducting designed for air distribution in greenhouses, available in rolls as long as 5000 ft. and in diameters from 6 - 24 inches. \*\* Drain-field pipe, polycarbonate columns, and similar “hard” column materials have also been employed with varying degrees of success. More extravagant systems utilize inner-rotating, perforated, hard columns equipped with centrally located air or water capillaries which double as support frames but I have yet to see such a system perfected. Many farms even use overhead trolleys for ferrying the columns into and out of the growing rooms. (See Figure 148). Of the many variations of Column Culture, the ease and inexpensiveness of the flexible poly-



Figure 168. Cross section of 15 inch diameter column of Oyster mushroom mycelium contaminated with an anaerobic core.

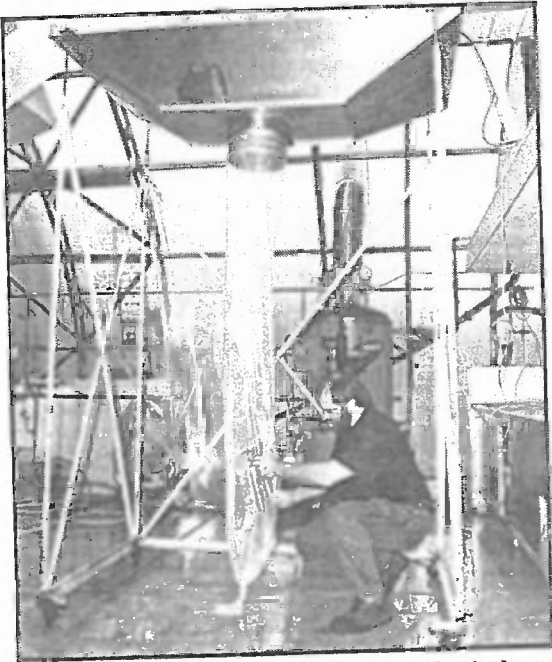

Figure 169. Inoculating columns. First, plastic ducting is cut to length and secured to the stainless steel funnel. (I had a spring-activated collar custom-made for this purpose.) A knot is tied several inches off the ground.

ethylene tubing has yet to be surpassed.

Some growers strip the columns after colonization to expose the greatest surface area. The columns are held together with two to four vertically running lengths of twine. Although the intention is to maximize yield, the massive loss of moisture, combined with the die-back of exposed mycelium, can cancel any advantage contemplated. El-Kattan (1991) and others who have conducted extensive studies have found the accumulation of carbon dioxide during colonization has an enhancing effect on subsequent yields. Studies prove the partially perforated plastic gives rise to larger fruitings of Oyster mushrooms sooner than substrates fully exposed. Exposed columns not only lose more moisture, but they also allow the sudden escape of carbon dioxide, resulting in a substan-

tial reduction of the total mass of the substrate. Controlling the loss of carbon dioxide has a beneficial impact on overall yield. Zadrazil (1976) showed that fully 50% of the mass of wheat straw evolves into gaseous carbon dioxide during the course of Oyster mushroom production. (See Figure 39.)

Another factor in choosing a type of column culture is greatly determined by the mushroom strain. Strains of Oyster mushrooms which produce clusters of many mushrooms, and which are site-specific to the perforations, work better in the perforated column model than in the fully exposed one. Mushroom strains which produce only one, two or three mushrooms per cluster—as with some *Pleurotus pulmonarius* cultures—do not demonstrate an obvious advantage with the perforated column method. Hence, the benefits of perforated column can be easily overlooked unless you test many Oyster

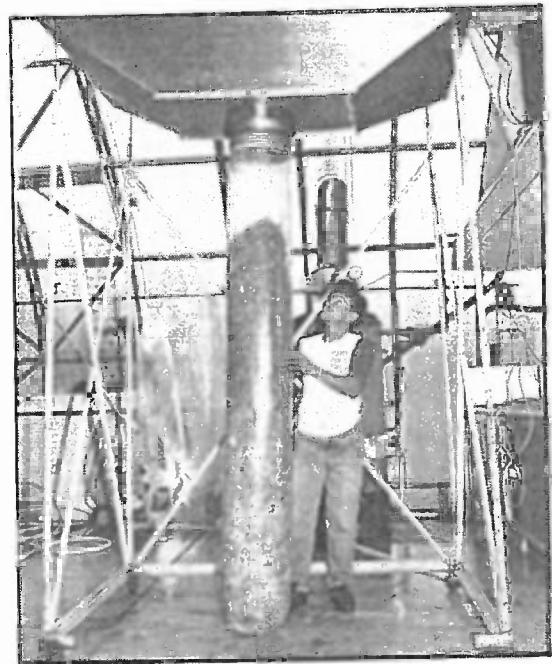

Figure 170. As the substrate fills the column, spawn is added and the plastic elongates.



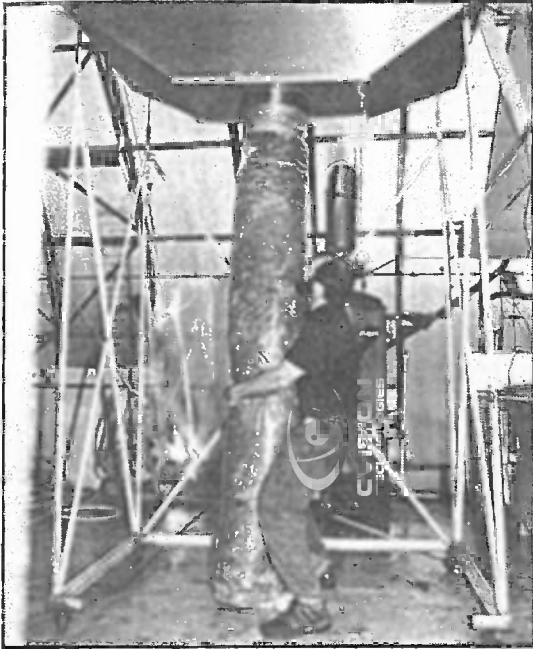

Figure 171. By slamming the column to the floor during filling, the straw packs densely.

mushroom strains.

From extensive trials, I have determined functional limits in the cultivation of Oyster mushrooms in columns. Columns less than 8 inches give meager fruitings and dry out quickly. Columns whose diameter exceeds 14 inches are in danger of becoming anaerobic at the core. Anaerobic cores create sites of contamination which emanate outwards, often overwhelming the outer layer of mycelium. (See Figure 168.)

Columns are best filled with bulk, pasteurized substrates (such as straw) via conveyors leading to a stainless steel funnel. If conveyors are unavailable, then the pasteurized straw can be moved from the steam room (Phase II box) to a smooth table top via a pitch-fork. Either on the conveyor or on the table top, grain spawn is evenly distributed. The inoculated substrate is then directed to the recessed funnel. The funnel should be positioned 10-14 ft. above the

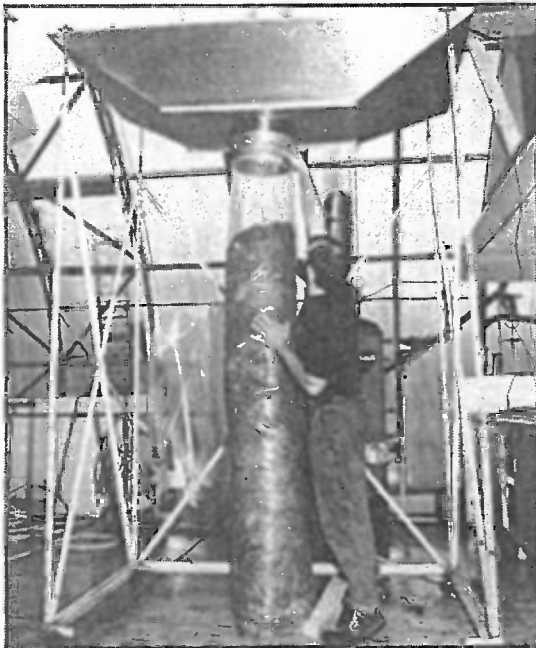

Figure 172 & 173. Once filled, the collar is released and the plastic is tied into a knot.

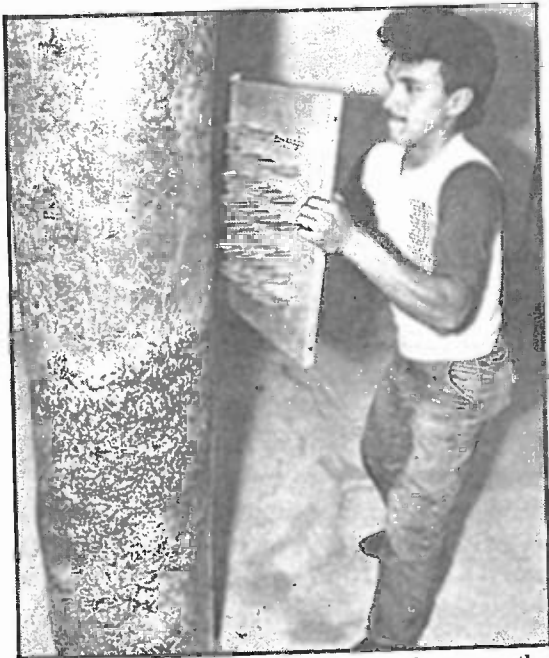

Figure 174. Once ferried into the growing room, the column is inverted so that the loose straw at the top is compressed. Stainless steel arrowhead heads mounted on a board are used to puncture 200-400 holes in each plastic column. Note that 75% of the weight of the column is floor-supported.

floor. Plastic ducting is pre-cut into 12 ft. lengths and tied into a tight knot at one end. The open end of the plastic tube is pulled over the cylindrical down-spout of the funnel and secured with "bungee cords" or, preferably, a spring-activated, locking collar.

Since the tensile strength of a 12 in. diameter, 4 mil. thick, polyethylene tube is insufficient to suspend the mass of moist straw tightly packed into an 8 ft. long column, care must be taken in filling. After securing the empty plastic column 4-6 inches above the floor, the plastic column slowly elongates with substrate filling. When a few air-release holes are punched near the bottom of the column, air escapes during filling, facilitating loading. Most importantly, cavities—air pockets—must be eliminated. As the



Figure 175. The same column as portrayed in Figures 135-140, 12 days later after inoculation with grain spawn of the Pink Oyster mushroom (*Pleurotus djamor*). 27 lbs. of fresh mushrooms were harvested on the first flush.

column is filled, the poly-tubing stretches until partially supported by the floor. As the column fills with substrate, a worker hugs the column, gently lifts it several inches off the floor, and forcibly slams it downwards. (See Figure 171). The impact against the floor increases substrate density and eliminates cavities. This ritual is repeated until the column is filled to a height of approximately 10 feet.

Once the column has been filled to capacity, the securing collar is removed by a person standing on a small step ladder. The column is tied off at the top using whatever means deemed most efficient (a twist-tie, knot, collar, etc. ). The column is carefully taken away from the inoculation station and another tube is immediately secured for the next fill of inocu-

lated substrate. An 8-ft. long column, 12 inches in diameter, tightly packed can weigh 120-150 lbs. depending upon moisture content, density (determined largely by particle or "chop" size), and spawn rate.

After the top folds of the column have been secured, the column should be inverted, upside down. The loosely packed substrate that was in the top 2 feet of the column is now at the bottom and the dense substrate at the bottom of the column is now switched to the top. This, in effect, packs the column tightly. If the straw is not tightly pressed against the plastic, causing substantial cavities, mushrooms form behind the plastic and develop abnormally. In contrast, tight fills cause the substrate and plastic to be forcibly in contact with one another. When an arrowhead puncture is made, the plastic bursts. The mycelium is exposed to the growing room's oxygen rich, humidified atmosphere. Given proper lighting and temperature conditions, a population of primordia form specific to each puncture site. Growers using this technique develop a particular fondness for strains which are site-specific to the punctures in their response to standard initiation strategies.

Once the column is removed from the inoculation station, two people carry or trolley it to the growing room, where it is hung and allowed to incubate. Overhead trolley systems similar to those employed in slaughter houses, cold storage rooms, even clothes dry-cleaner companies can be adapted for this purpose. If the columns are carried, care must be taken so that the columns do not sag in the middle, lest they break. Modified hand-trucks fitted with a slant board are helpful in this regard.

The columns are hung to approximately 4 inches above the floor. After hanging, they noticeably stretch within a few seconds to become substantially floor supported. Columns (10

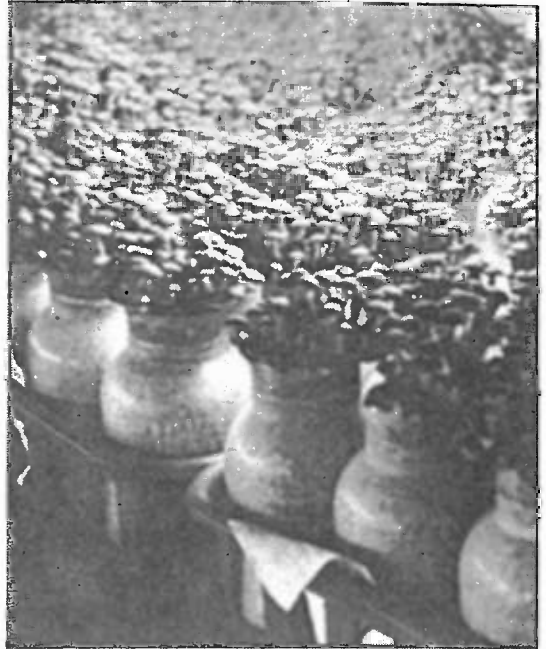

Figure 176. Bottle culture of a dark gray strain of *Hypsizygus tessulatus*, known in Japan as Buna-shimeji or Yamabiko Hon-shimeji. This mushroom is currently being marketed in America as just "Shimeji". The Japanese prefer to use the Latin name *Hypsizygus marmoreus* for this mushroom. For more information, please consult Chapter 21.

inches in diameter and greater) suspended in the air after inoculation will probably fall before the cropping cycle is completed.

Directly after the columns have settled to the floor, within 1 hour, numerous holes must be punched for aeration. If holes are not punched until the next day, substantial loss of spawn viability occurs, and a bacterial bloom ensues in the stagnant, air-deprived column. However, if the column is suspended and holes are punched too soon, the punctures elongate and the column soon is in danger of splitting apart. For an 8 ft. high column, 12 inches in diameter, at least 200 and no more than 400 1/8 in. holes should be punched for maximum yield. Stainless steel, four bladed arrowheads, mounted on a board are recommended for this



Figure 177. Bottle culture of a Magic Mushroom known as *Psilocybe cubensis*.

purpose. (See Figure 174). Although the puncture hole is only 1/8 inch in diameter, four slits 1-2 inches in length are also made. These flaps open as the mushrooms push through.

### Bottle Culture

Bottle culture is an effective means for growing a variety of gourmet and medicinal mushrooms on sterilized substrates. However, bottle culture is impractical for the cultivation of mushrooms on pasteurized bulk substrates such as straw or compost. San Antonio (1971) first published a method for growing *Agaricus brunnescens*, the Button mushroom, on cased, sterilized grain from bottles. This article be-



Figure 178. Sterilized sawdust inoculated via top-spawning.

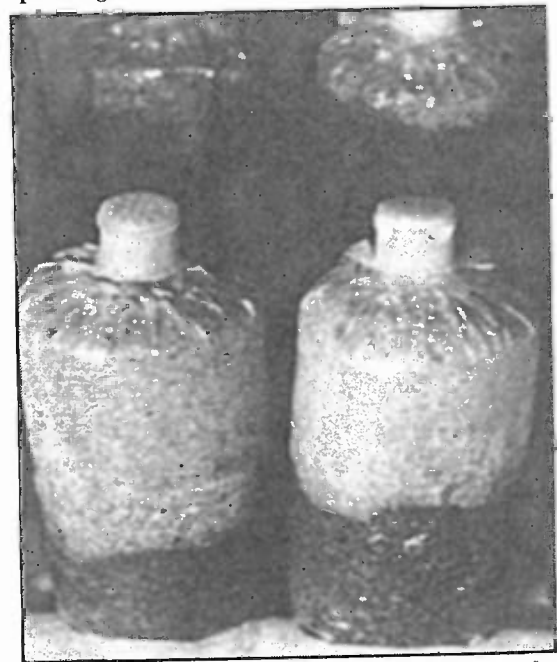

Figure 179. Downwardly growing mycelium a week after inoculation into sterilized sawdust.

came a template for the cultivation of many other mushrooms. A counter-culture book on psilocybian mushroom cultivation by Oss & Oeric (1976) (a. k. a. Dennis & Terence McKenna) brought the concept of bottle culture to the forefront of small-scale mushroom cultivators in America. Currently, Asian growers have adapted bottle culture, originally designed for the easy cropping of Enoki mushrooms (*Flammulina velutipes*), to the cultivation of many other gourmet and medicinal mushrooms, including Buna-shimeji (*Hypsizygos tessulatus*), Reishi (*Ganoderma lucidum*), Wood Ears (*Auricularia polytricha*), and some varieties of Oyster mushrooms.

The advantage of bottle culture is that the process can be highly compartmentalized and easily incorporated into the many high speed production systems adapted from other industries. The disadvantage of bottle culture is that sawdust substrates must be top-spawned and

grain spawn can not be easily mixed through bottles containing sawdust. The bottles are filled to within 2 inches of the brim with moistened supplemented sawdust and then sterilized for 2-4 hours at 15-20 psi. (The formula is the same for bag culture of Shiitake and Enokitake. Please refer to Chapter 17.) When grain spawn is added at inoculation, and the bottles are shaken, the spawn descends to a depth of only a few inches. Hence, the mycelium quickly covers the top surface layer and then grows slowly downwards into the sterilized sawdust. This results in imbalanced time frames in terms of the age of the mycelium at the top vs. the bottom of the bottle. The newly growing mycelium near the bottom inhibits the formation of mushrooms in the top layer of mycelium. The discrepancy in age inhibits maximum mushroom formation from the total surface area of the substrate. When the mycelium is actively growing out, the total mycelial colony can not

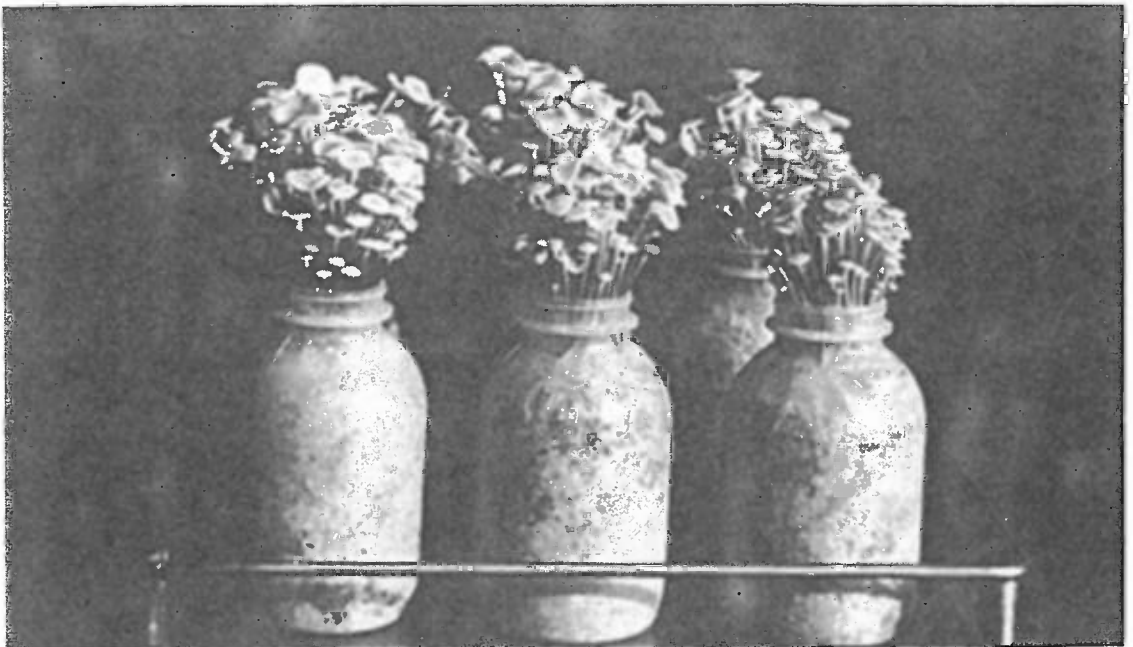

Figure 180. Bottle culture of Enoki mushrooms (*Flammulina velutipes*) on sterilized alder sawdust.

easily shift from colonization to primordia formation.

An advantage of this method is that mushrooms, when they do form, arise from the most mature mycelium, at the top of the bottles. Side and bottom fruitings are rare. If the cultivator can afford to make the initial investment of incubating thousands of bottles until the first cycle starts, then the drawbacks are primarily that of lost time and delay in the initial production cycle, but not overall yield. Top-spawning is fast and convenient for bottle and small bag culture, although I see more benefits from through-spawning. Many cultivators in Japan accelerate the colonization process by inoculating the bottles with pressurized liquid spawn.

With the natural evolution of techniques, Asian cultivators have replaced bottles with similarly shaped, cylindrical bags. This hybrid method is preferred by many growers in Thailand, Taiwan and Japan.

Liquid inoculation of sterilized, supplemented sawdust allows for inoculation methods resembling the high production systems seen in a soda pop factory. With re-engineering, such high speed assembly line machinery could be

retrofitted for commercial bottle and bag cultivation. Unless an aggregate-slurry is used, liquid spawn settles near to the bottom of the bottles. (For a complete discussion of liquid fermentation and inoculation techniques, please refer to Chapter 15). Bottles can be arranged horizontally in walls or fruited vertically. In Japan, bottle culture is the method preferred by many cultivators in the growing of Yamabiko Hon-shimeji or Buna-shimeji (*Hypsizygus tessulatus* varieties), Shirotamogitake (*Hypsizygus ulmarius*), Enokitake (*Flammulina velutipes*) and Reishi (*Ganoderma lucidum*).

Bottles of various sizes can be used. The most common are between 1 quart (1 liter) and 1 gallon (4 liters). The openings are usually between 50-100 mm. in diameter. Glass bottles are not as popular as those made from polypropylene-like materials. Each bottle is fitted with foiled cotton or an autoclavable lid equipped with a microporous filter disc. After full colonization, the lids are removed, and the surface mycelium is exposed to the growing room environment. Enoki growers often insert a coil of paper or clear plastic to encourage stem elongation.

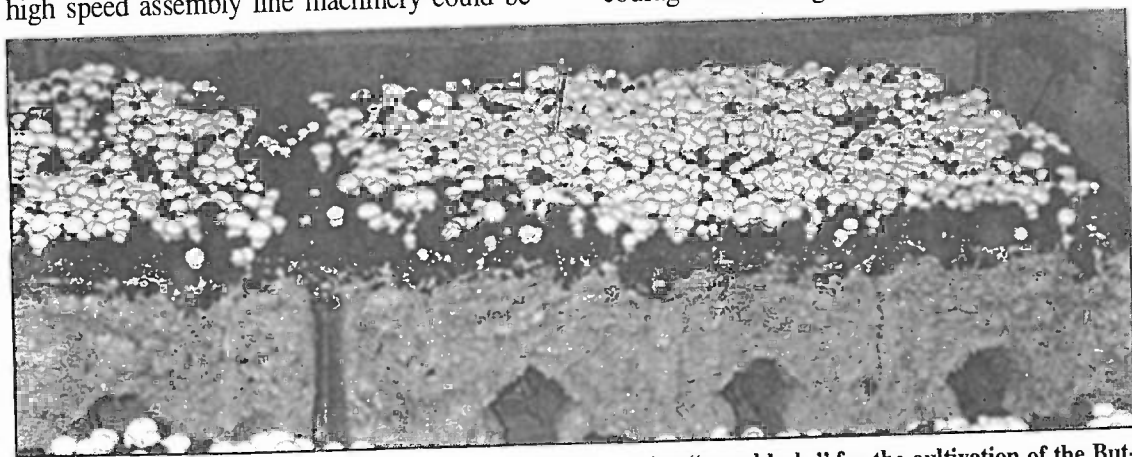
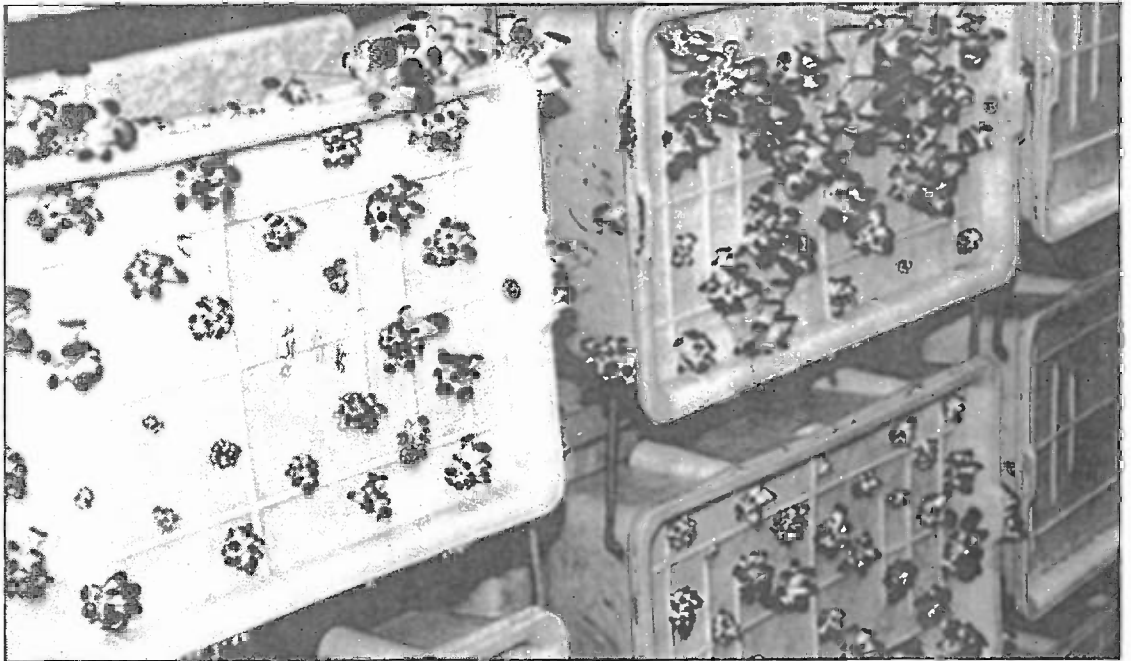

Figure 181. Compacted compost formed to create self-supporting "megablocks" for the cultivation of the Button Mushroom, *Agaricus brunnescens*. This ingenious, British method of cultivation is being patented. (U.K. Patent #953006987.1) The cavities allow transpiration and prevent anaerobic cores.



Figures 182 and 183. Oyster mushrooms (*Pleurotus ostreatus*) fruiting from suspended, perforated, plastic containers. A group of innovative Russian cultivators are refining this method.





Figures 184 and 185. Applying a peat moss casing.



Figure 186. One week later, mycelium grows close to the surface.

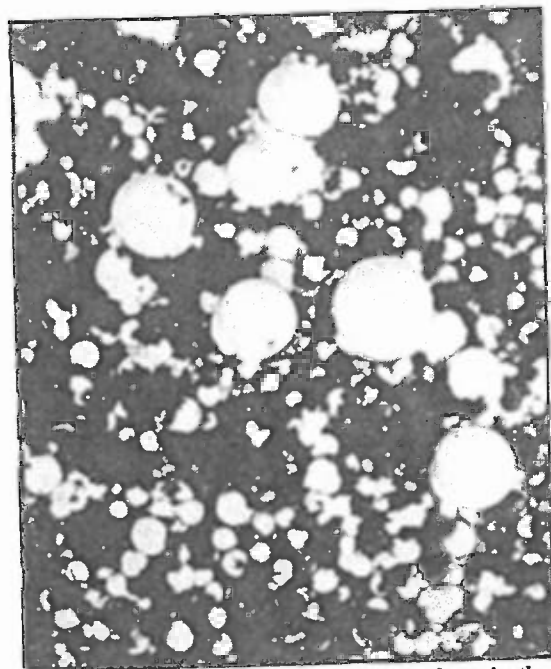

Figure 187. Two weeks later, primordia form in the casing layer.



## Casing: A Topsoil Promoting Mushroom Formation

**B**utton growers long ago discovered that, by placing a layer of peat moss over compost grown through with mushroom mycelium, yields were greatly enhanced. The casing served several functions. Foremost, the casing layer acted as a moisture bank where water reserves could be replenished through the course of each crop. The casing layer also limits damage to the mycelium from fluctuations in relative humidity. Besides moisture, the casing provides stimulatory micro-organisms, essential salts and minerals. These combined properties make casing a perfect environment for the formation and development of primordia.

In the cultivation of gourmet and medicinal mushrooms, casing soils have limited applications. Cultivators should be forewarned that green-mold contamination often occurs with soil-based casing layers, especially when air circulation is poor and coupled with contact with wood. The possible benefits of casing are often outweighed by the risks they pose. Few saprophytic gourmet species are absolutely dependent upon casing soils, with the exception of the King Stropharia, (*Stropharia rugoso-annulata*).

A dozen or so casing soils have been used successfully in the commercial cultivation of mushrooms. They all revolve around a central set of components: peat moss, vermiculite, calcium carbonate (chalk), and calcium sulfate (gypsum). Recently, "water crystals," a water-capturing plastic, have been tried as a casing component with varying results. These crystals can absorb up to 400 times their weight in water and do not support contaminants, two highly desirable characteristics. Unfortunately, the fact that water crystals are not fully biodegradable and can not be easily recovered from the spent substrate greatly limits their acceptance by environmentally astute growers. Starch-based water absorbants tend to clump and must be added with an aggregate. Cultivators must weigh in balance these factors when designing the casing mixture.

For many years, cultivators have used the following casing formula.

### Casing Formula (by volume)

- 10 units peat moss
- 1 unit calcium sulfate (gypsum)
- 1 unit calcium carbonate (chalk)

Calcium carbonate is used to offset the acidity of the peat moss and should be adjusted according to desired pH levels. Calcium sulfate, a non-pH affecting salt\*, provides looseness (particle separation), and mineral salts, especially sulphur and calcium, essential elements for mushroom metabolism. Peat moss, although lacking in nutrition, is resplendent with mushroom stimulating bacteria and yeasts. The above-described formula depends greatly on the starting pH of the peat moss. Generally, the pH of the resultant mixture is 7.5-8.5 after make-up. As the mushroom mycelium colonizes the casing layer, pH gradually falls. For some acid-loving species mentioned in this

book, calcium carbonate should be excluded. Typically, this chalk-free mixture gives pH readings from 5.5-6.5.

Mix the dry components together in a clean bucket or wheel barrow. Add water slowly and evenly. When water can be squeezed out to form brief rivulets, then proper moisture has probably been achieved. A 75% moisture content is ideal and can be tested by measuring the moisture lost from a sample dried in a hot oven.

Once wetted, the casing is applied to the top of a substrate, but only after it has been thoroughly colonized with mycelium. Casing soils are best used with tray, bag, or outdoor mound culture. Although some of the following mushroom species are not absolutely dependent upon a casing soil, many benefit from it. Those species marked with an "\*" are dependent upon soil microorganisms for fruitbody formation. Under sterile conditions, the "\*" species will not fruit well, or at all. Typically, a one-inch layer of casing soil is a placed onto 4-10 inches of myceliated substrate.

<i>Agaricus brunnescens</i> *	The Button Mushroom
<i>Agaricus bitorquis</i> *	The Warm Weather Button Mushroom
<i>Agrocybe aegerita</i> ,	The Black Poplar Mushroom
<i>Coprinus comatus</i>	The Shaggy Mane
<i>Ganoderma lucidum</i> ,	Reishi or Ling Chi

\* Gypsum, calcium sulfate, may affect pH by 1/2 of a point. Its pH-altering ability is minor until the sulphur evolves into sulfuric acid. Calcium and sulphur are essential elements in mushroom metabolic processes. If the substrate is lacking in these essential elements, yields are adversely affected. Shiitake, in particular, benefits from the addition of calcium sulfate to sawdust substrates.

# Growth Parameters for Gourmet and Medicinal Mushroom Species

**T**he parameters outlined here are based on the author's experiences over many years of cultivation. Each mushroom species thrives on a limited range of substrates. However, strains within a species are even more specific in their habitat requirements, temperature preferences, and their flushing intervals. Wherever possible, I have identified individual strains so that readers can achieve similar yields. These strains are being kept in perpetuity in the Stamets Culture Collection. Some strains are proprietary and can be obtained by contacting the author through his business **Fungi Perfecti**. Most species can be obtained from a number of culture libraries such as the American Type Culture Collection. These sources are listed in the Resource section in Appendix IV.

To remain competitive, cultivators must continuously search out and develop new strains from wild stocks. Although specific temperature parameters are outlined in this section, some strains will perform better outside of these prescribed limits. In general, rapid

cycling strains prefer higher temperatures. The cold weather strains require a longer gestation period before fruiting. The cultivator must customize initiation strategies to each strain, a process fine-tuned with experience.

For instance, I isolated a strain of the Winter Mushroom or Enokitake, *Flammulina velutipes*, from the high-altitude forests outside of Telluride, Colorado in 1990. Typically, strains of this mushroom produce at temperatures around 45-55° F. (7-13° C.). This isolate produces prolifically between 65-75° F. (18-24° C.), outside of any published parameters for this mushroom. In this case, the classic initiation strategy of cold-shocking is unnecessary. If you are a commercial cultivator of Enoki mushrooms, spending thousands of dollars a year on refrigeration systems, this unique strain has exceptional monetary value.

Of the many factors already described for producing successful crops, the mis-application of only one can result in poor fruitings or absolute failure. *Each grower is strongly encouraged to conduct mini-trials before endeavoring commercial cultivation.*

Optimization of yields is realized only if the grower becomes keenly sensitive to, and satisfies the unique needs of, each mushroom strain. Therefore, the following parameters should be used as a general guide, to be refined in time and with experience. The first set of parameters is centered on the incubation period, called SPAWN RUN; the second set is for initiating mushrooms, called PRIMORDIA FORMATION and the third is for cropping or FRUITBODY DEVELOPMENT. In essence, each stage of mushroom growth has a different ideal environment. As each factor is changed, secondary effects are seen. The skill of a mushroom cultivator is measured by the ability to

compensate for fluctuations in this complex mosaic of variables.

## SPAWN RUN: Colonizing the Substrate

Spawn run spans the period of time when the mycelium is colonizing the substrate. Other than the factors described below, the amount of spawn inoculated into the substrate can greatly affect the duration of colonization, and therefore, the time to fruiting.

**Moisture:** Substrate moisture contents should be between 60 and 75%. Moisture contents below 40% promote slow, wispy mycelial growth. Unless a casing layer is used, the moisture content of the substrate gradually declines from initial inoculation. For instance, the water content of straw at inoculation is nearly 75%, precipitously dropping after the first flush to the 60% range, and continuing to steadily decline through the remainder of the cropping cycle. The cultivator's prime responsibility during this period is to manage the moisture reservoir as if it were a bank. Moisture loss must be limited before initiation or else the mycelium will fail in its efforts to generate mushrooms, which are themselves about 90% water. The solution: retard the loss of substrate moisture by maintaining high humidity during spawn run.

**Air Exchange:** Mushroom mycelium is remarkable for its tolerance for carbon dioxide. At levels snuffing out the life of a human, mycelium thrives. Some Oyster mushrooms' growth rates peak at 20% carbon dioxide, or 200,000 ppm. However, this CO<sub>2</sub> environment is equally stimulatory to competitor molds. The best level varies with the strain, and whether one is working with pasteurized or sterilized substrates.

To reduce carbon dioxide, fresh outside air

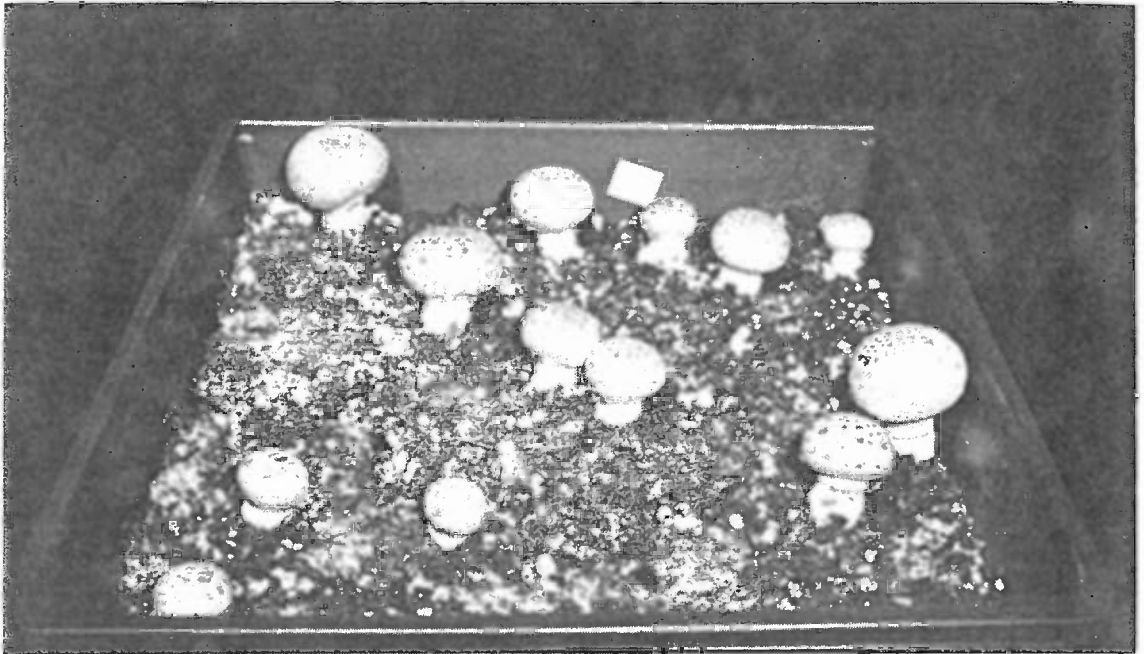

Figure 188. The Button mushroom (*Agaricus brunnescens*) fruiting from cased grain.

is introduced. Consequently, several other phenomena occur: evaporation is increased, humidity drops, temperature changes, and the net number of contaminant particles entering the growing room rises as air exchanges are increased.

*Temperature:* As a general rule, incubation temperature runs higher than the temperature for primordia formation. Internal temperatures should not exceed 95° F. (35° C.) or black pin molds and other thermophilic competitors will awaken, especially under the rich CO<sub>2</sub> conditions created as a by-product of spawn running.

*Lighting:* For the species described in this book, moderate lighting has no effect, adverse or advantageous, on the mycelium during spawn run. Bright, unfiltered, direct sunlight is damaging. Light is especially harmful when intensities exceed 10,000 lux. From my experiences, the mycelial mat only becomes

photosensitive after it has achieved a threshold critical mass, usually coincident with full colonization, and after carbon dioxide evolution has steeply declined.

## PRIMORDIA FORMATION: The Initiation Strategy

By far the most critical step is that of primordia formation, called *the initiation strategy*. An initiation strategy can be best described as a shift in environmental variables, triggering the formation of mushrooms. The four major environmental factors operative in an initiation strategy are: *moisture, air exchange, temperature and light*. These are adjusted accordingly:

*Moisture:* Direct watering is applied, coupled with a constant, controlled rate of evaporation to maintain high humidity between 95-100%. Fog-like conditions are



Figure 189. A Magic Mushroom (*Psilocybe cubensis*) fruiting from cased grain.

important when aerial mycelium is first exposed to the growing room environment. Once primordia form, a gradual reduction of humidity from 100% to 90-95% usually is beneficial. Humidity should be measured in at least three locations in the free air spaces directly above the mycelium-permeated substrate.

**Air Exchange:** Air is exchanged to precipitously lower carbon dioxide and to suddenly provide oxygen.  $\text{CO}_2$  levels should be below 1000 ppm, ideally below 500 ppm for maximum mushroom formation. Air exchange should be adjusted specifically to lower  $\text{CO}_2$  to the specified levels outlined for each species in the following growth parameters.

**Temperature:** Many strains will not form mushrooms unless temperature is dropped or raised to a critical plateau. For most strains, a temperature drop is required. Since mush-

room formation is primarily a surface phenomenon, the atmosphere of the growing room has to be altered to affect a temperature change in the substrate. As a substrate is being colonized with mycelium, heat is released as a by-product. After colonization is complete, heat generation abates, and internal temperatures naturally decline to nearly equal with air temperature. This is the ideal time to synchronize the other factors favorable to mushroom formation. Note that the temperature thresholds listed for each species are what cultivators call the bed, or substrate, temperature. Air temperature is adjusted upwards or downwards to affect the desired change. When air temperature is changed, a lag time follows, often for 24-72 hours, before the substrate temperature adjusts to the prerequisite level. In most cases, the critical temperature plateau occurs within 2-4 inches

of the surface, the region supporting the creation of primordia.

*Light:* In nature, light acts as a signal alerting the mycelium to an open-air environment where, should mushrooms form, spores can be spread into the air. Light controls stem elongation and cap development. Ideal light conditions—intensity and wavelength—vary with each species and strain. Indirect natural light, or the dappled light filtering through a forest canopy, is considered ideal for woodland mushrooms. Specific photo-periods and spectral frequencies have not yet been established for all mushroom species. In these cases, cultivators resort to providing the lighting necessary to the most sensitive of the gourmet mushrooms, the *Pleurotus* species. Modest light is not harmful to developing mushroom mycelium; it seems unaffected by its presence. *Direct sunlight or high intensity exposure is harmful.* The fluorescent lights used in indoor facilities do not inhibit mycelial growth, and in some circumstances may stimulate early primordia formation. For most species, light levels between and 50-1000 lux and 380-480 nanometers (green to blue) seem most stimulatory to primordia formation. (I use six 8 ft. long, “Daylight” 6500 Kelvin fluorescents to light each 1000 sq. ft. growing room which also gets supplemental natural light through a row of diffusion panels.) For specific light requirements, please consult the growth parameters for the species being cultivated.

Leatham and Stahlman (1987, 1989) conducted trials with Shiitake on chemically defined media which showed that the absence of calcium made the mycelium unresponsive to light stimulation. At low calcium levels (< 40  $\mu\text{g}/\text{mg}$ ) Shiitake mycelium formed mushrooms when stimulated by light between 600-680 nanometers or red light. At high calcium (>130

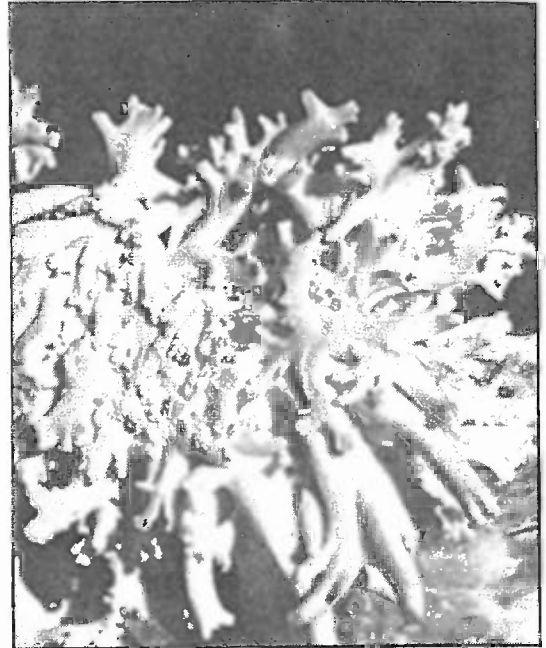

Figure 190. Lack of light causes Oyster mushrooms to malform into coral-like structures.

$\mu\text{g}/\text{mg}$ .) levels, the wavelengths most stimulatory for primordia formation were between 400-500 nanometers, what we know as blue to ultraviolet light. Calcium is naturally present in woods in sufficient quantities to allow fruiting. Just as strains of Shiitake differ in their fruiting cycles, I suspect that the “calcium factor” in triggering Shiitake formation may be strain specific. Nevertheless, the interplay between light and calcium concentrations continues to be a subject of great interest. Further studies are needed to compare the many strains, on various woods, with varying levels of calcium, and at different wavelengths.

The body of mycelium is not as sensitive to these environmental stimuli until the substrate, its impending food source, has become fully captured by it. Where there are zones of *uncolonized* substrate, the mycelium continues

on its conquest of nutrients, and fruitings are delayed until colonization is complete. Substrates that are carefully and evenly inoculated colonize faster, responding readily to the four environmental stimuli described above. When the rapidly growing mycelium is forced to stop because of natural borders or contact with competitors the mycelium shifts gears—biologically speaking—from conquest to consolidation. The mycelium consolidates its hold of the substrate by the infinite microscopic branching of hyphae. Concurrent with this phase change, the mycelium and the substrate cools. For Oyster mushroom cultivators, this period of declining temperature leads directly to primordia formation. At this juncture, the cultivator adjusts the surrounding environment—introducing light, dropping temperature,

exchanging air, and increasing moisture—to stimulate the greatest number of primordia.

Some mycologists take a different view of what causes this shift to fruiting in the mushroom life cycle. They describe the sudden lack of food for the mycelium as *nutrient deprivation*. The best example of this is the Morel. Once the sclerotia have formed remote from the nutrient base, the nutrient base is physically separated from the sclerotial colonies, and this loss of nutrition is one of the triggers stimulating fruitbody formation. (This is basically the pivotal technique upon which the patent was awarded for growing morels—see Ower et al., 1978). In my mind, this is a clear case of true nutrient deprivation. However, substrate separation techniques are not generally used in the cultivation of Oyster, Shiitake, Enoki, Lion's Mane, Maitake, Wood Ear and many of the

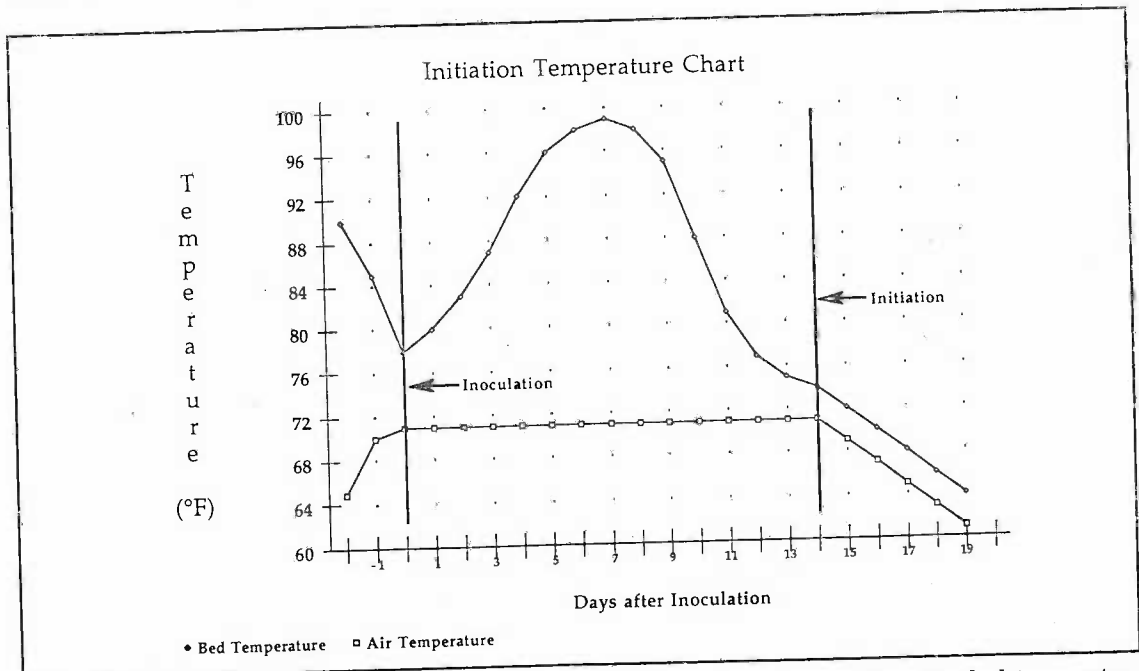

Figure 191. Chart of air vs. substrate ("bed") temperature during colonization. Note that bed temperature naturally declines as colonization is completed while air temperature remains constant. An initiation strategy (i.e. dropping temperature, adding moisture, increasing light and exchanging air) is instigated to augment the mycelium's natural progression to fruiting.



other gourmet and medicinal mushrooms. More accurately, I would described these fruitings as being triggered by *nutrient limitation*, not deprivation.

## FRUITBODY (Mushroom) DEVELOPMENT

*Moisture:* Atmospheric moisture must be carefully managed to allow mushroom development but not to the advantage of competitors. While relative humidity approaches 100% during primordia formation, it should be lowered to levels whereby a constant rate of evaporation is drawn from the fruitbodies. The crop should be sprayed several times a day, as long as the excess water is soon reabsorbed by either the mushrooms, the substrate, or the air. This dynamic process of replenishment and loss encourages the best crops of mushrooms. The humidity in the growing room is often reduced several hours prior to picking, extending the shelf life of the crop. This is where the "Art" of cultivation plays a critical role in affecting quality.

*Air Exchange:* Air exchange and turbulence are managed for maximum benefit of the mushrooms, in terms of reducing carbon dioxide levels, elevating oxygen concentration, and to effect the constant evaporation of moisture from the surfaces of the maturing mushrooms.

*Temperature:* Temperature levels either remain the same or are raised. Typically after primordia formation, temperature controls the

speed of development of the fruitbody. Naturally, warmer temperatures result in faster growth while colder temperatures slow development. One advantage of fruiting at a cooler temperature is that a firmer-fleshed, higher-quality mushroom forms at the time of harvest.

*Lighting:* Without adequate light, stem elongation and malformation of the cap occur. Oyster and Enoki mushrooms are especially sensitive. Also strong light alters the pigment of the developing mushrooms. Some strains of Oyster mushrooms darken under bright light conditions; others pale. This response is also affected by temperature.

*Duration:* The timing of crops; their first appearance, the duration of harvest, and the period of time between crops are strain and process dependent. With Shiitake on sterilized sawdust/chips/bran, I go for 4 or 5 crops. With Oyster mushrooms grown in columns on pasteurized straw, two to three flushes seem most efficient. Approximately seven days to two weeks separate the end of the first flush to the beginning of the second. Fruiting occurs within time frames, or "windows of opportunities." A period of dormancy is required between crops so nutrients can be accumulated as the mycelium prepares for the next crop. During these windows of opportunity, the cultivator must actively signal the mushroom mycelium with as many environmental stimuli as possible. Synchronizing this combination of events gives rise to the best possible fruitings.



## The Gilled Mushrooms

**T**he gilled mushrooms are the archetypal forms we all recognize. They are typically umbrella shaped, with cylindrical stems and plates radiating outwards from the undersides of the caps. Oyster, Shiitake and Enoki are classic gilled mushrooms. Taxonomically, these mushrooms fall into the Order Agaricales. Microscopically, they all produce spores by means of club-shaped cells called basidia.\*

The most extensive treatise on the taxonomy of gilled mushrooms has to be Rolf Singer's *Agaricales in Modern Taxonomy* (1986). This massive work is the pivotal reference text on the overall systematics of fungal taxonomy. As the science of mycology progresses, individual monographs on a genus or a section of a genus delve more precisely into inter-species relationships. Alexander Smith's *Mushrooms in their Natural Habitat* (1949) still stands as the template for describing mushrooms macroscopically, microscopically and in their relationship to the natural environment. These two works, in combination, have had the greatest influence on the course of American mycology in the 20th century.

\* For a discussion of basidia, consult Chapter 9. See Figures 47 to 52.

## The Black Poplar Mushroom of the Genus *Agrocybe*

### *Agrocybe aegerita* (Brigantini) Singer

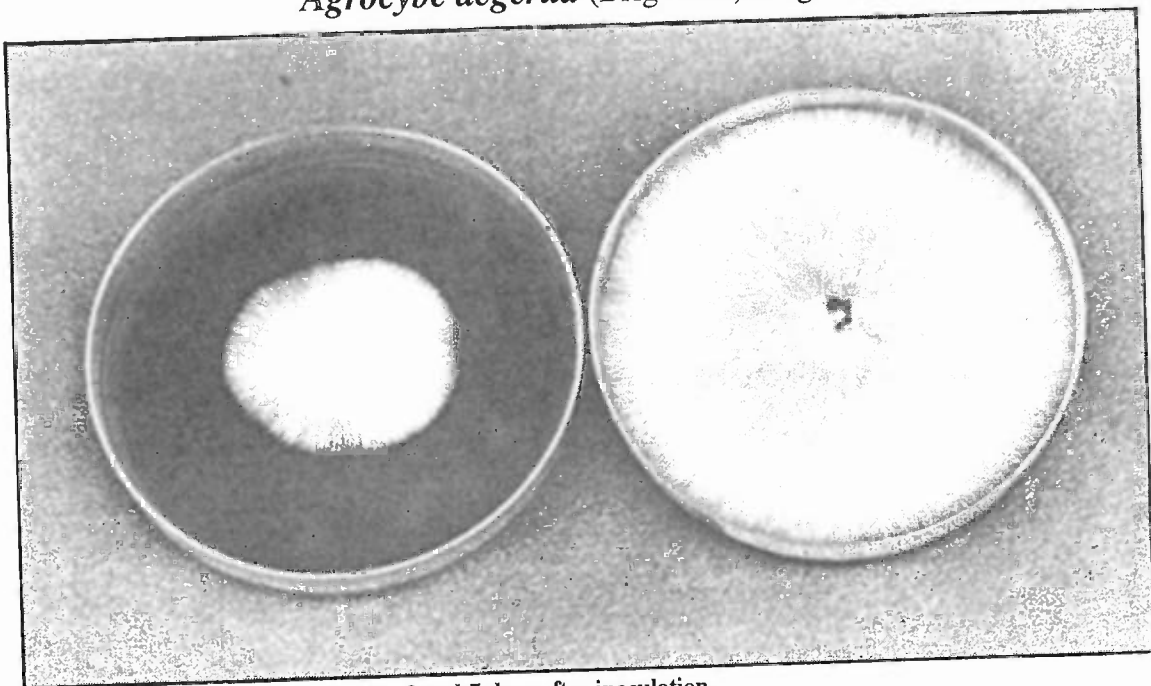

Figure 192. Mycelium of *A. aegerita* 3 and 7 days after inoculation.

**Introduction:** This mushroom has a mellow and attractive flavor when young. *Agrocybe aegerita* grows prolifically on deciduous wood debris, often forming large clusters—both in nature and in the controlled environment of the growing room. This species is an excellent candidate for stump recycling, especially in the southeastern United States.

**Common Names:** The Black Poplar Mushroom  
 The Swordbelt Agrocybe  
 Yanagi-matsutake (Japanese)  
 Pioppino (Italian)  
 South Poplar Mushroom or Zhuzhuang-Tiantougu (Chinese)

**Taxonomic Synonyms & Considerations:** A variable fungus which may well be split into several distinct taxa with more research, this mushroom was once called a *Pholiota*, *P. aegerita*. Other synonyms are *Pholiota cylindracea* Gillet (Singer, 1986), or *Agrocybe cylindracea* (DC. ex Fr.) Maire, a name still preferred by Asian mycologists. Watling (1982) prefers *Agrocybe cylindrica* (De Candolle ex Fries) Maire. *Agrocybe molesta* (Lasch) Singer and *A. praecox* (Pers. ex Fr.) Fayod are related species and may be cultivated using the same methods described here. Their flavor, in the opinion of many mycophagists, is not as good as *A. aegerita*. More work on the taxa of the southeastern Agrocybes is needed.



Figure 193. 20 days after inoculation, *primorida* voluntarily form on malt extract agar.

**Description:** A substantial mushroom, often up to 12 inches in diameter. Cap convex, to hemispheric, expanding to plane at maturity, smooth, yellowish gray to grayish brown to tan to dingy brown, darker towards the center. Gills gray at first, becoming chocolate brown with spore maturity. Stem white, adorned with a well developed membranous ring, usually colored brown from spore fall.

**Natural Habitat:** Growing saprophytically, often in clusters, on stumps in the southeastern United States and southern Europe. Preferring hardwoods, especially cottonwoods, willows, poplars, maples, box elders, and in China on tea-oil trees.

**Distribution:** Not known to occur in North America outside of the southeastern states of Mississippi, Louisiana and Georgia. Common across southern Europe and in similar climatic zones of the Far East.

**Microscopic Features:** Spores smooth, ovoid to slightly ellipsoid, brown,  $9-11 \times 5-6.5(7)\mu$ , lacking a distinct germ pore. Clamp connections present.

**Available Strains:** Strains are commonly available from culture libraries. Most strains cloned from wild specimens produce on hardwoods.

**Mycelial Characteristics:** Longitudinally linear, becoming cottony, usually not aerial. White at first, soon becoming spotted brown, and eventually tan brown. Primordia usually form on malt extract agar media.

**Fragrance Signature:** Mealy, farinaceous, but not pleasant.

**Natural Method of Cultivation:** Stumps of the above-mentioned trees. Outdoor wood chips beds also produce, much in the same manner as for the cultivation of *Stropharia rugoso-annulata*.

**Recommended Courses for Expansion of Mycelial Mass to Achieve Fruiting:** Petri dish cultures blended via Eberbach stirrers to create liquid inoculum which is, in turn, injected into sterilized grain. This grain spawn can be used to make sawdust spawn for outdoor inoculations or for inoculating directly into supplemented, sterilized, hardwood sawdust.

**Suggested Agar Culture Media:** Malt Yeast Peptone Agar (MYPA), Potato Dextrose Yeast Agar (PDYA), Oatmeal Yeast Agar (OMYA) & Dog Food Agar (DFA).

**1st, 2nd and 3rd Generation Spawn Media:** Cereal grains (rye, wheat, milo, sorghum, etc.) for 1st

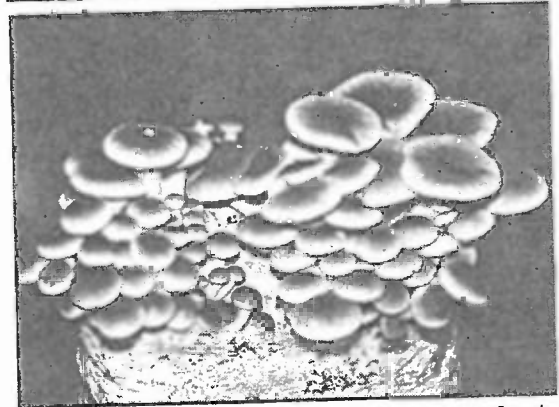
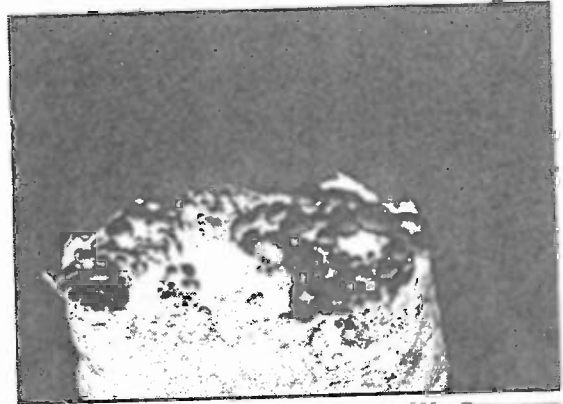
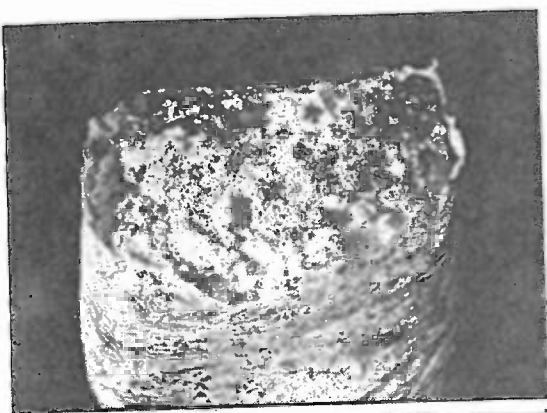

Figures 194-197. The Black Poplar mushroom (*Agrocybe aegerita*) fruiting on supplemented alder sawdust/chips 32, 33, 34 and 35 days after inoculation.

and 2nd generation spawn. Sawdust is recommended for the 3rd generation, which can then be used to as spawn for inoculation directly into slices cut into stumps. Sawdust spawn is also recommended for inoculation into sterilized, supplemented hardwood sawdust.

**Substrates for Fruiting:** I have fruited this species on supplemented oak and alder sawdust/chips. Willow, poplar, cottonwood, and maple also support substantial fruitings.

**Recommended Containers for Fruiting:** Polypropylene bags and trays. This mushroom is better grown from horizontal surfaces than from vertical ones.

**Yield Potentials:** Up to 1 lb. of fresh mushrooms per 5-6 lb. block of sterilized sawdust/chips/bran. Given the size of fruitings occurring naturally, large diameter willow, poplar and cottonwood stumps could sustain massive fruitings for many years.

**Harvest Hints:** A more fragile mushroom than it at first appears, this mushroom should be encouraged to grow in clusters. If mushrooms are harvested before the veils break, shelf-life is prolonged.

**Form of Product Sold to Market:** Fresh, because of this mushroom's resemblance to the Button mushroom (*Agaricus brunnescens*) marketing is not as difficult as with many "new" species.

## Growth Parameters

### Spawn Run:

Incubation Temperature: 70-80° F. (21-27° C.)

Relative Humidity: 95-100%

Duration: 20-28 days

CO<sub>2</sub>: > 20,000 ppm.

Fresh Air Exchanges: 0-1 per hour.

Light Requirements: n/a

### Primordia Formation:

Initiation Temperature: 50-60° F. (10-16° C.)

Relative Humidity: 95-100%

Duration: 7-14 days

CO<sub>2</sub>: < 2000 ppm.

Fresh Air Exchanges: 4-8 per hour.

Light Requirements: 500-1000 lux.

### Fruitbody Development:

Incubation Temperature: 55-65° F. (13-18° C.)

Relative Humidity: 90-95%

Duration: 4-6 days

CO<sub>2</sub>: < 2000 ppm.

Fresh Air Exchanges: 4-8 per hour

Light Requirements: 500-1000 lux.

### Cropping Cycle:

Two flushes, 10-14 days apart.

---

**Nutritional Content:** Not known to this author.

**Medicinal Properties:** None known, although closely related species produce unique antibiotics.

**Flavor, Preparation and Cooking:** Finely chopped and stir fried, cooked in a white sauce and poured onto a fish or chicken, or baked in a stuffing, this species imparts a mild but satisfying, pork-like flavor.

**Comments:** This mushroom benefits from the application of a 1/2 inch casing directly onto the top surface layer of mycelium. However, if a condensing fog environment is provided, combined with high turbulence, an even plane of primordia can form absent any casing layer. (See Figures 194-197). For cluster formation, primordia should be encouraged to appear in groups of 4-20.

This species figures as one of the best for recycling stumps in the humid southeastern United States. The willow-populated swamps of Louisiana seem like an ideal setting for the deliberate cultivation of *A. aegerita*. Regions of Chile, Japan and the Far East, as well as southern Europe have coincident weather patterns that should support growth.

---

## The Shaggy Mane of the Genus *Coprinus*

### *Coprinus comatus* (Muller: Fries) S.F. Gray

**Introduction:** Shaggy Manes have long been a favorite amongst mushroomers in North America and Europe. Easy to identify, often growing in massive quantities, this brilliant white mushroom is hard to miss and difficult to confuse with poisonous species. Their fragile constitution and unique method of self-destruction, combined with their mild but excellent flavor, has made the Shaggy Mane a popular mushroom amongst hikers and hunters.

After experimenting with its cultivation, I am pleasantly surprised at how well this species adapts to a wide variety of indoor and outdoor substrates. Although the commercial cultivation of this mushroom is limited by its predisposition to disintegrate into an inky mess, this mushroom is fantastic for those who can consume it within two days of picking.

**Common Names:** The Shaggy Mane  
Lawyer's Wig  
Maotou-Guisan (Chinese)

**Taxonomic Synonyms and Considerations:** *Coprinus comatus* is considered a taxonomically "clean" species by most mycologists and can be accurately identified by sight.

**Description:** Cap 4-10 (15) cm. high by 3-4 (5) cm. thick, vertically oblong, dingy brown at first, soon white, and decorated with ascending scales. Gills crowded, white to pale, long, broad and slightly attached or free to the stem. Stem 6-12 (15 cm.) long by 1-2 cm. thick, equal, hollow, bulbous at the base, and adorned with a movable, membranous collar-like ring, that separates from the cap margin as the mushrooms enlarge. As the mushrooms mature, the gills blacken, or "deliquesce", transforming into a black, spore-laden fluid which drips from the rapidly receding cap margin. The cap eventually totally recedes, leaving only the stem.

**Distribution:** Growing in the late summer and fall throughout the temperate regions of the world.

**Natural Habitat:** In lawns, meadows, around barnyards, in wood chips, along roadsides, and in enriched soils.

**Microscopic Features:** Spores black, 11-15 x 6.0-8.5  $\mu$ , ellipsoid, with a germ pore at one end. Subhymenium cellular.

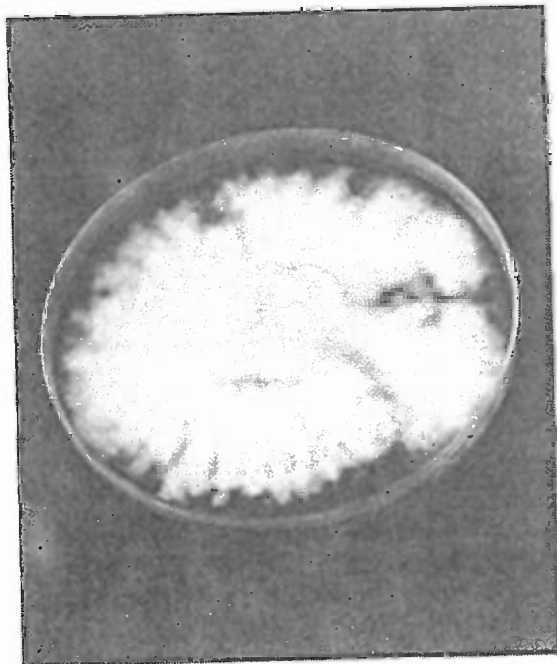

Figure 198. Classic, cottony Shaggy Mane mycelium on malt extract agar.



## Growth Parameters

### Spawn Run:

Incubation Temperature: 70-80° F. (21-27° C.)

Relative Humidity: 95-100%

Duration: 12-14 days.

CO<sub>2</sub>: 5000-20,000 ppm.

Fresh Air Exchanges: 0-1

Light Requirements: n/a

### Primordia Formation:

Initiation Temperature: 60-70° F. (16-21° C.)

Relative Humidity: 95-100%.

Duration: 12-15 days after casing.

CO<sub>2</sub>: 500-1000 ppm.

Fresh Air Exchanges: 4-8 per hour.

Light Requirements: 500-1000 lux for 8 hours per day.

### Fruitbody Development:

Incubation Temperature: 65-75° F. (18-24° C.)

Relative Humidity: 80-90%.

Duration: 5-7 days

CO<sub>2</sub>: 500-1000 ppm.

Fresh Air Exchanges: 4-8 per hour.

Light Requirements: 500-1000 lux for 8 hours per day.

### Cropping Cycle:

Two to three flushes, four to ten days apart.

---

**Available Strains:** This mushroom is easy to clone. Cultures are widely available from libraries throughout the world. However, a sporeless strain is needed before commercial cultivation will become practical. I have isolated a late-sporulating strain from a fruiting on manure enriched sawdust. Sporeless strains are needed as the maturing spores trigger deliquescence, causing the mushrooms to disintegrate into a black spore-enriched fluid. This spore liquid presents unique problems to cultivators in their attempts to isolate spores away from contaminants.

**Mycelial Characteristics:** Mycelium usually white, cottony, aerial, often develops "tufts" (hyphal aggregates) with maturity. Most strains form mycelial mats asymmetrically shaped along the outer edge. (See Figure 198).

**Fragrance Signature:** Farinaceous and mildly sweet.

**Natural Method of Cultivation:** Inoculation of spawn directly into manure enriched soils or 4-6 inch deep beds of hardwood sawdust. Newly laid or fertilized lawns that are frequently watered are perfect habitats for Shaggy Manes. Cow or horse manure, mixed with straw or sawdust, are also ideal.

---

Hardwood sawdust spawn should be used as inoculum for establishing outdoor patches.

**Recommended Courses for Expansion of Mycelial Mass to Achieve Fruiting:** Adaptive to liquid fermentation, grain spawn can be created with ease. Grain spawn is directly inoculated into pasteurized, supplemented straw-based composts. My experiences with bran-supplemented sawdust has resulted in poor yields compared to manure enriched straw-based substrates. Primordial dials form on sawdust but often fail to further develop.

**Suggested Agar Culture Media:** PDA, PDYA, MEA, MPYA, DFA, or OMYA.

**1st, 2nd and 3rd Generation Spawn Media:** Grain (rye, wheat, sorghum) throughout.

**Substrates for Fruiting:** The straw/manure compost formulas described by Stamets & Chilton (1983) support substantial fruitings of this mushroom. Another excellent medium can be made from the manure and urea-enriched sawdust discharged from horse stables. Paper and pulp waste also support fruitings. \* Like most coprophiles, this mushroom greatly benefits from the placement of a peat moss based, casing soil.

**Recommended Containers for Fruiting:** Trays and bags. This mushroom is not inclined to grow from anything but horizontal surfaces.

**Yield Potentials:** When soya flour was added at a rate of 2% to paper pulp fiber (giving the substrate a 0.5 % nitrogen content), yields approached 80% B.E.. However, these yields were lower than that generated from manure compost which often exceed 100% B. E. (See Mueller et al. (1985)).

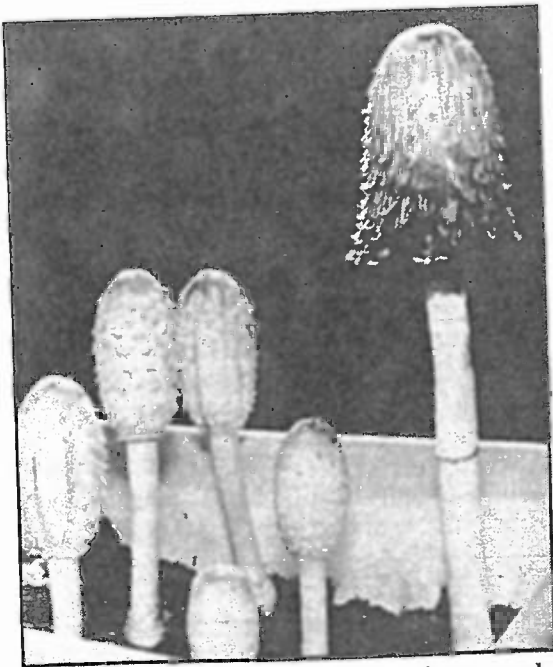

Figure 199. Shaggy Manes fruiting from cased, horse manure-enriched straw.



Figure 200. Shaggy Manes fruiting from cased, leached cow manure.

**Harvest Hints:** Since this mushroom deliquesces from the end of the gills upwards to the stipe, mushrooms should be picked before the slightest hint of the gills turning black. If picked when no basidia have matured, mushrooms can be kept in cold storage for 4-5 days. Any mushrooms that begin to deliquesce should be removed from the fresher fruitbodies since the enzymes secreted by one deliquescing mushroom will decompose adjacent mushrooms, regardless of age.

**Form of Product Sold to Market:** If this mushroom ever gets to market, it is there all too briefly due to self-deliquescence. In the matter of two days from harvest, the mushrooms turn into a black ink-like slurry unless precautions are not taken. Mushrooms can be preserved by submerging them in cold water and storing them under refrigeration. Packing Shaggy Manes in refrigerated, nitrogen gas filled containers also extends shelf life. Currently, Shaggy Manes that are sold at farmer's markets are usually from wild collections. Young shaggy manes can be thinly sliced and quickly dried for storage. Freeze drying is also an option.

**Nutritional Content:** 25-29% protein (N x 4. 38); 3% fat; 59% carbohydrates; 3-7% fiber and 1.18% ash. (Crisan & Sands (1978); Samajpati (1979)).

**Medicinal Properties:** A novel antibiotic has been isolated from this species and is currently being characterized by American researchers. Ying (1987, pg. 313) reports that the "inhibition rates against sarcoma 180 and Ehrlich carcinoma are 100% and 90% respectively." The references are in Chinese. No other research on the anti-tumor properties of this mushroom is known to this author.

**Flavor, Preparation & Cooking:** Shaggy Manes were the first mushrooms that seduced me into the art of mycophagy. It may seem odd, but I prefer this mushroom for breakfast. I like to prepare the mushrooms by frying thinly cut dials (stem included) in a frying pan with onions and light oil. Once they are slightly browned, the mushrooms are used to compose an omelet. Or, fry the mushrooms in butter at medium heat and serve on whole wheat toast. Many of the recipes listed in this book can incorporate Shaggy Manes. Since this mushroom has considerably more moisture than, Shiitake for instance, the water should be cooked off before other ingredients are added to the frying pan.

\* Mushroom production on pulp waste stopped in British Columbia in the late 1980's after concerns about residual, heavy metal contamination. Please check with paper manufacturers before using their products as a substrate for mushroom production.



Figure 201. Shaggy Manes fruiting in yard that was inoculated with sawdust spawn the year before. Shaggy Manes wander, often fruiting meters away from the original site of inoculation.

**Comments:** This is a great mushroom to grow in your yard and in compost piles. Once an outdoor patch is established, Shaggy Manes can fruit for many years. For impatient cultivators, indoor cultivation is recommended. For mycological landscapers not concerned about territorial confinement of their mushroom patch, the Shaggy Mane is an excellent companion to garden plants.

After pasteurized compost is inoculated, the substrate is completely colonized in two weeks with a cottony, non-rhizomorphic mycelium. When colonization is complete, a moist casing (peat moss/gypsum) layer is applied. After 10 days, the mycelium can be seen reaching through the upper surface of the casing. At this stage, lower the temperature, increase watering, and introduce light to stimulate fruiting. Yields can be substantially increased if the casing layer is vigorously raked just as the mycelium begins to show on the surface of the casing.

The primordia form as circular dials, between the size of a dime to a quarter. The primordia are unique in that they are wide and flat. An inner collar forms within the dial and arises to form a dome. This dome soon shoots up to form a recognizable mushroom. The circular zone visible at the primordial stage becomes the movable ring resting on the stem of the mature mushroom.

For more information, consult Van de Bogart (1976), Stamets & Chilton (1983), and Mueller et al. (1985).

---

---

## The Enoki Mushroom

### *Flammulina velutipes* (Curtis: Fries) Singer

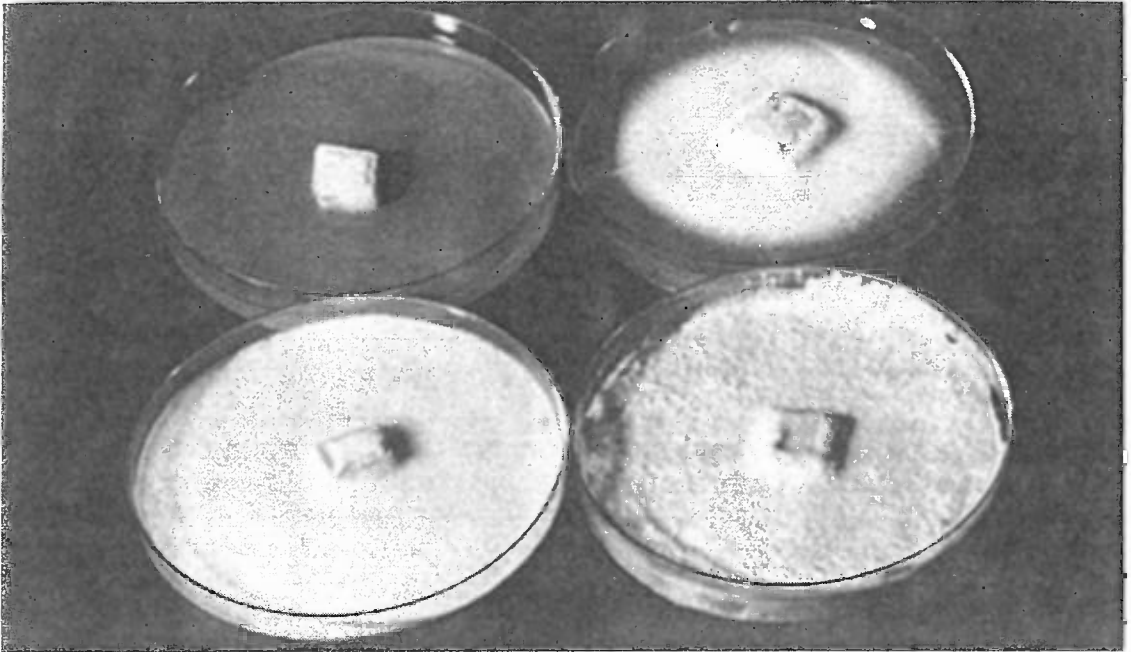

Figure 202. Mycelium of Enokitake, 3, 8, 14 and 28 days after inoculation.

**Introduction:** The Japanese lead in popularizing this mushroom. In the wild, *Flammulina velutipes* is a short, furry footed mushroom. Usually cultured in chilled growing rooms, abnormally small caps and long stems are achieved by elevating carbon dioxide levels and limiting light exposure. This unnatural shape makes the harvesting of Enoki easy.

**Common Names:** Enokitake (Japanese for “The Snow Peak Mushroom. Enokidake is an alternative spelling)  
 Nametake (“Slimy Mushroom”)  
 Yuki-motase (“Snow Mushroom”)  
 The Winter Mushroom  
 The Velvet or Furry Foot Collybia  
 The Golden Mushroom (Thailand)

**Taxonomic Synonyms and Considerations:** Formerly known as *Collybia velutipes* (Fr.) Quel.

**Description:** Cap 1-5 cm. in diameter, convex to plane to upturned in age, smooth, viscid when wet, bright to dull yellowish to yellowish brown to orangish brown. Gills white to yellow, attached to the stem. Stem usually short 1-3 inches, yellow to yellowish brown, darkening with age and covered with

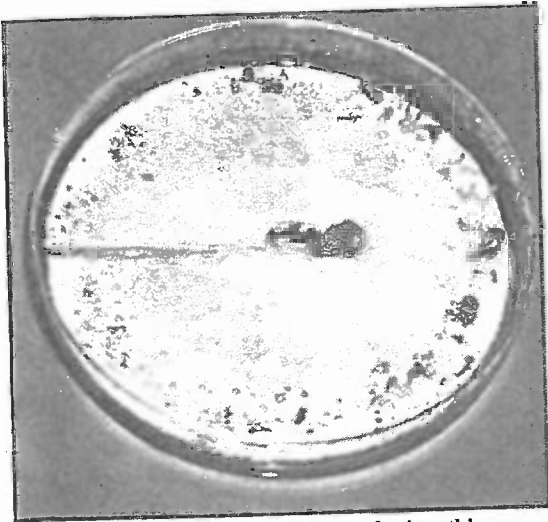

Figure 203. After three weeks of incubation, this warm weather strain of Enokitake produces abundant primordia at room temperature. Most strains of the species require a cold shock to form primordia.



Figure 204. Wild fruiting of *Flammulina velutipes* from stump. Note shortness of stems and breadth of caps of wild vs. cultivated fruitings.

a dense coat of velvety fine brown hairs near the base. In culture, the morphology of this mushroom is highly mutable, being extremely sensitive to carbon dioxide and light levels. Cultivated specimens usually have long yellowish stems, small white to yellowish caps. When spores mature, the caps darken to brown.

**Distribution:** Widespread throughout the temperate regions of the world, growing from sea level to tree-line.

**Natural Habitat:** Primarily on hardwoods, occasionally on conifers, commonly growing in the late fall through early winter. This mushroom can freeze, thaw, and continue to grow. One definition of "Enoki" in Japanese is huckleberry, implying that this mushroom grows on that shrub in Japan.

**Microscopic Features:** Spores white, 6-8 x 3-4  $\mu$ , ellipsoid. Hongo (1988) lists a spore size of Japanese varieties of 5-7.5 x 3-4  $\mu$ . Moser (1983) reports spores of European collections measuring 8-9 x 4.5-6  $\mu$ . These differences may underscore the wide range of varieties included within this complex. Clamp connections present.

**Available Strains:** Vast populations of this species thrive in the wild, offering cultivators a rich resource for new strains. Most strains require a cold shock and/or growth in temperature ranges from 40-60° F. (4-13° C.) In August of 1990, I isolated an aggressive strain from tree line (10,000+ ft.) in the mountains above Telluride, Colorado. The strain is unique, not requiring cold shock, producing

---

## Growth Parameters

### Spawn Run:

Incubation Temperature: 70-75° F. (21-24° C.)

Relative Humidity: 95-100%

Duration: 14-18 days

CO<sub>2</sub>: >5000 ppm

Fresh Air Exchanges: 0-1

Light Requirements: n/a

### Primordia Formation:

Initiation Temperature: 45-50° F. (7-10° C.)

Relative Humidity: 95-100%

Duration: 3-5 days

CO<sub>2</sub>: 2000-4000 ppm

Fresh Air Exchanges: 2-4 per hour

Light Requirements: 100-200 lux.

### Fruitbody Development:

Temperature: 50-60° F. (10-16° C.)

Relative Humidity: 90-95%

Duration: 5-8 days

CO<sub>2</sub>: 2000-4000 ppm

Fresh Air Exchanges: 2-4 per hour.

Light Requirements: 100-200 lux.

### Cropping Cycle:

Two to three crops, 10-12 days apart.

---

mushrooms at 70-75° F. (21-24° C.). Strains of this mushroom vary in their sensitivity to light and carbon dioxide levels.

**Mycelial Characteristics:** White, longitudinally linear, becoming finely appressed and tinged light brown to spotted with golden yellow brown zones with age. The surface roughens, resembling fine sand paper, and sometimes becomes beaded at the earliest stage of primordia formation. Long stemmed, small capped mushrooms commonly form along the inside periphery of the petri dish or during cold storage of culture slants.

**Fragrance Signature:** Grain spawn musty smelling, not pleasant.

**Natural Method of Cultivation:** Stump culture is possible, as evidenced by the penchant that this species has for logs, stumps, and wood debris in the wild. However, stump culture should not be encouraged to those who can not distinguish Enoki mushrooms from the small, wood decomposing poisonous mushrooms such as the deadly members of the Genus *Galerina* or *Conocybe*.

---

**Recommended Courses for Expansion of Mycelial Mass to Achieve Fruiting:** Liquid inoculated grain spawn mixed directly through sterilized, supplemented sawdust at a rate of 10-15%. The rapidly decomposing hardwoods such as alder, cottonwood, willow, aspen, and poplar are recommended. If selecting cultures actively forming primordia, and placing the mycelium into the Eberbach for the generation of liquid inoculated grain spawn, the duration from colonization to fruiting can be shortened by a week. The timely disturbance of developing primordia often results in bursts of re-growth.

**Suggested Agar Culture Media:** PDYA, MYA, OMA or DFA.

**1st, 2nd and 3rd Generation Spawn Media:** Grain spawn throughout.

**Substrates for Fruiting:** A wide variety of hardwoods (oak, alder, poplar, cottonwood,

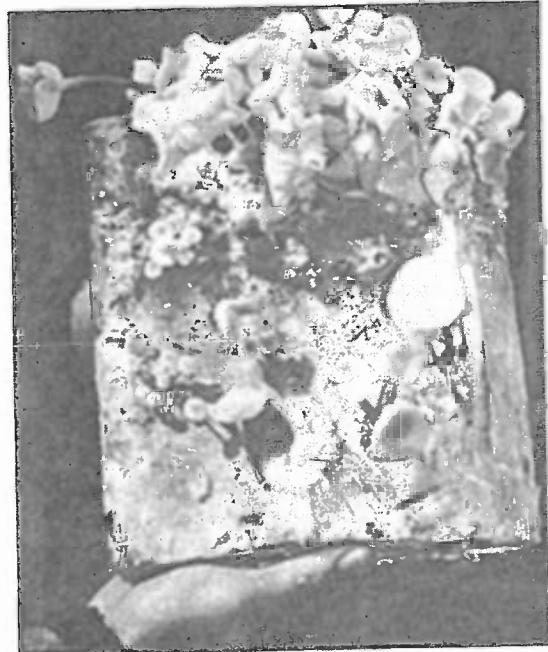

Figure 205. Enoki mushrooms fruiting from the book, *The Mushroom Cultivator*.

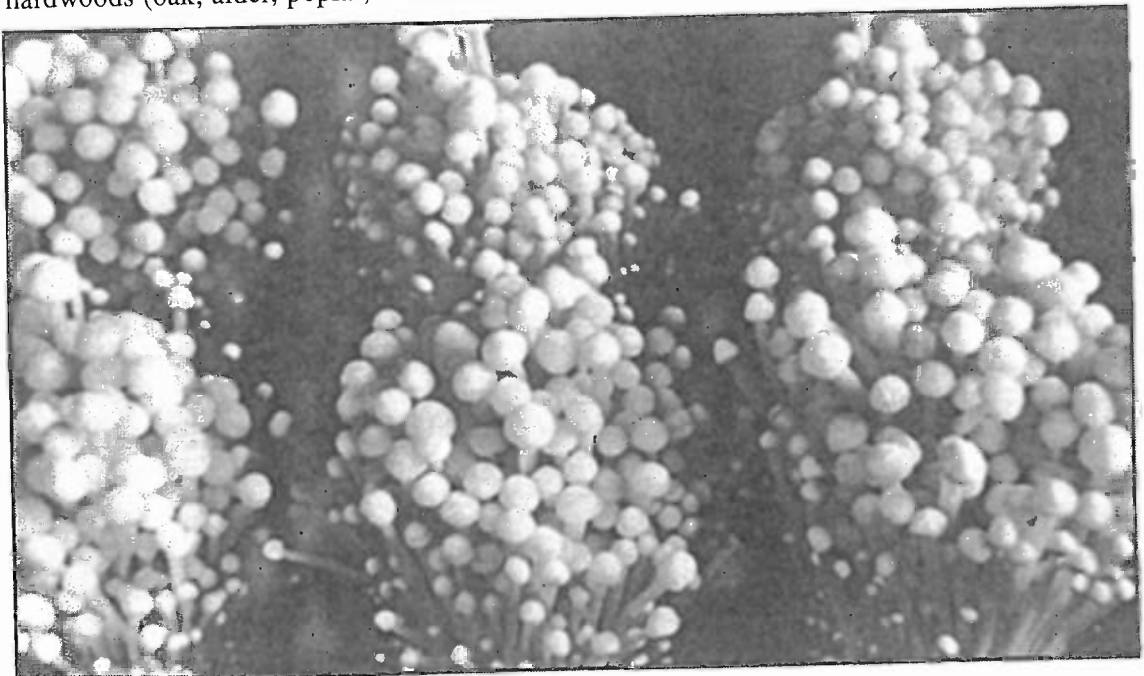

Figure 206. Bottle culture of Enokitake in Japan.



aspen, willow, birch, beech, etc.), and some softwoods (Douglas fir) although the latter is, in general, less productive. The pH range for fruiting falls between 5-6. Enokitake also grows on a wide variety of paper products.

**Recommended Containers for Fruiting:** Most automated Enoki farms utilize polypropylene bottles for ease of handling and speed of harvesting. A cylinder of plastic or paper is formed into a cylinder fitted within the open top of each bottle. This causes the stems to grow long and facilitates harvesting. If grown in bags, the side walls of the bags should extend 6 inches above the plane of the fruiting surface to encourage the desirable elongated stems. The plastic walls are stripped down just prior to harvest.

**Yield Potentials:** Biological efficiency rating to 150%, the preponderance of which is stem mass. If grown in 1 liter bottles, yields of 3-5 oz. are standard for the first flush.

**Harvest Hints:** The difficulty of picking several hundred mushrooms, one by one, is daunting. By stimulating the elongation of the stem through CO<sub>2</sub> elevation, cropping can be quickly accomplished. If culturing in bottles, firmly grasp the cluster and pull. With either method, trim any residual substrate debris off with a knife or a pair of scissors. Some strains of Enoki re-assimilate the damaged stem butts and form more primordia upon them for the second flush. If only minor cap development is allowed, and the mushrooms are picked before the gills mature, shelf life is greatly extended. However, some connoisseurs favor the flavor of the tender cap over the tougher, stringy stem.

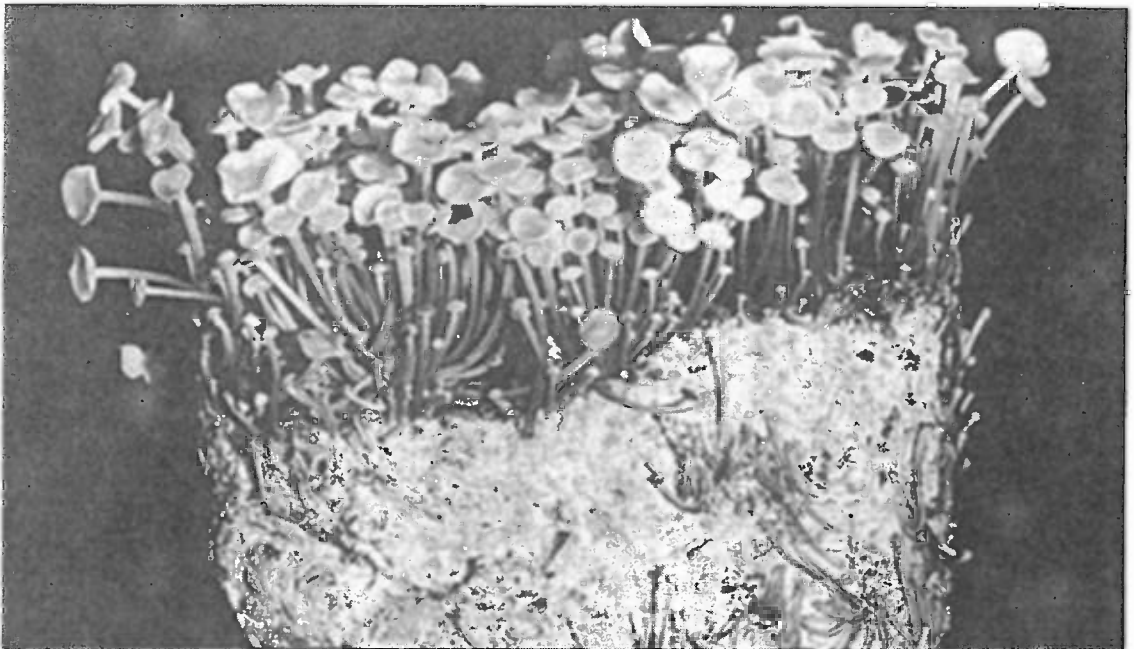

Figure 207. Enoki mushrooms fruiting from block of supplemented alder sawdust.

**Form of Product Sold to Market:** Bunches of whitish to yellowish, long stemmed mushrooms are usually shrink-wrapped and marketed in 3 or 5 oz. packages. Most of the Enoki available is brought into this country from Japan.

**Nutritional Content:** Variable, influenced by substrate components. Crude protein: 17-31%; fat 1.9-5.8%; fiber 3.7%; ash 7.4%.

**Medicinal Properties:** The water soluble, polysaccharide *flammulin*, is 80-100% effective against Sarcoma 180 and Ehrlich carcinoma according to Ying (1987). An epidemiological study in Japan, found a community of Enoki growers near the city of Nagano that had unusually low cancer rates. Frequent Enoki consumption was thought to be the cause. Ikekawa et al. (1968) reported anti-cancer activity from extracts of this mushroom. Studies of the anti-tumor properties of this mushroom has been published by Zeng et al. (1990) and Qingtian et al. (1991). The polysaccharide thought to be active is commonly referred to as "FVP" for "*Flammulina velutipes* polysaccharide".

**Flavor, Preparation & Cooking:** This mushroom is surprisingly flavorful, *including* the stems, an opinion not shared by Singer (1986). Traditionally, Enoki is lightly cooked, served in soups or in stir fries with vegetables, fish, and chicken. The stems are often left long, thus posing some interesting problems in swallowing. I prefer Enoki finely cut, almost diced, and then cooked at high heat for a

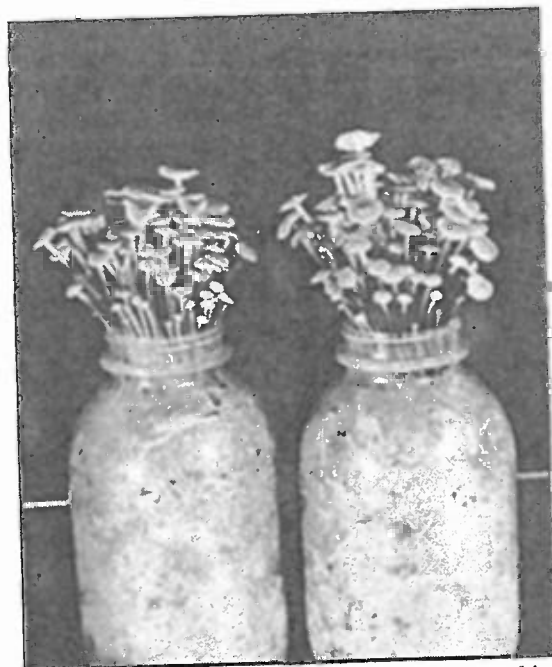

Figure 208 and 209. *Flammulina velutipes*, Enokitake, fruiting in bottles. Paper (or plastic) is inserted within the inside rim and helps concentrate carbon dioxide. The stems elongate in response, creating a crop that can be easily harvested. The paper is removed to reveal clusters averaging 5-6 ounces (140-170 grams). Skilled harvesters grasp mature mushroom clusters and pull them out by hand. Residual substrate debris is trimmed before the mushrooms are packaged for market.

short period of time. At a recent mycological society gathering, the addition of finely chopped Enoki to a cream sauce, stems and all, resulted in a *creme superieur*.

**Comments:** This mushroom is the classic example of the influences light and carbon dioxide have on fruitbody formation. Like Oyster mushrooms, this mushroom's appearance is contingent upon the environment in which it was grown. The growing room environment can be tuned to elicit the perfect crop. Over time, experienced growers can orchestrate flushes with precision and generate cluster-bouquets of golden mushrooms. Properly managed, each bundle achieves a remarkably similar weight.

Under outdoor conditions (moderate light/low CO<sub>2</sub>), this mushroom is short-stemmed with caps as wide as the stems are long. The lower regions of the stem develop a darkened fuzz, hence the common name "The Velvet Foot". Under the lighted, high carbon dioxide conditions, the stems greatly elongate and are yellow to white in color. The caps remain relatively small. While CO<sub>2</sub> determines the length of the stem, light is an overriding factor in influencing the formation and development of the cap. Thus under high CO<sub>2</sub> and no light conditions, thin stems may form usually without any caps. Most strains behave in this fashion but responses vary. Depending on the surrounding environment, the stems can be as short as 1 inch to as long as 12 inches. The cap to stem ratio varies from 1:1 to 1:100. This range in the shape of the fruitbody is remarkable.

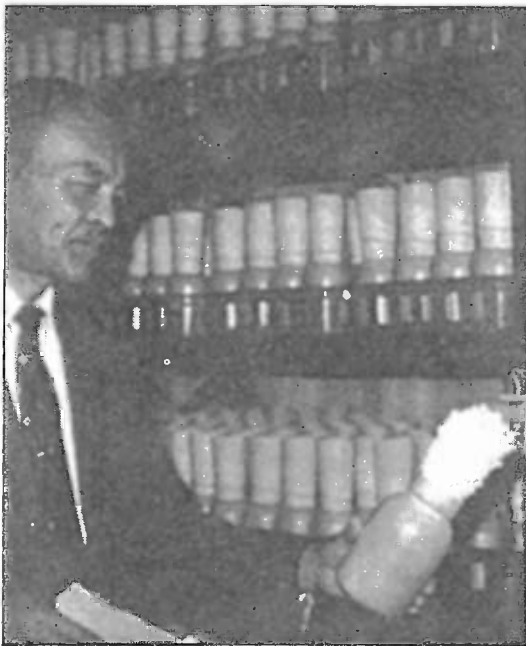

Figure 210. A Japanese Enoki-take cultivator.

The surface mycelium undergoes a radical transformation during the period of pre-primordia formation. The mycelium yellows, and then forms dingy, blemished brown and white zones, which soon evolve into a roughened, beaded surface. From this micro-landscape, a high population of minute, squat, yellow primordia emerge. The mushrooms appear virtually stemless. If carbon dioxide levels are kept elevated, above 5,000 ppm., significant stem elongation continues. Japanese cultivators have invented the technique of fruiting in bottles that are topped with a cylindrical insert of clear plastic or paper. The cylinder pools carbon dioxide and the stems elongate. This technique encourages the formation of highly uniform flushes of mushrooms in each bottle.

For more information on the development of the mushroom strains in response to humidity levels, see McKnight (1985, 1990, 1992).

## The Clustered Wood-lovers of the Genus *Hypholoma*

---

For cultivators, the Genus *Hypholoma* (Fries) Kummer includes several interesting species, all of which thrive in cold weather, not producing when temperatures exceed 60-65° F. (15-18° C.). Aggressive wood decomposers, they share similar cultural requirements, and produce a type of mycelium that is quite distinct from other saprophytes I have cultivated. Their uniquely beautiful mycelia is not only fantastically rhizomorphic, but luxuriously satin-like. After the mycelium has captured a substrate, a several week resting period precedes primordia formation. If this resting period can be shortened, indoor cultivation may prove more commercially feasible. With current methods, the *Hypholomas* endure and proliferate in outdoor settings and fit perfectly within the Natural Culture models described in this book.

*Hypholoma* means "mushrooms with threads" because of the thread-like veil that connects the cap to the stem when young and for the bundles of rhizomorphs radiating outwards from the stem base. In North America, the name *Naematoloma* was used for years to delimit the fleshier species of this genus, following usage by Singer & Smith. However, *Hypholoma* has been officially conserved against *Naematoloma*, which means that only the name *Hypholoma* is proper to use.

Species of *Hypholoma* are closely related to *Psilocybe* and *Stropharia*. These genera belong to the family Strophariaceae (or sub-family Stropharioideae sensu Singer). They are distinguished from one another on the basis of microscopic features, features so subtle that many researchers have remarked on the usefulness of representing this group as one, enveloping macro-genus. Since *Psilocybe* was published first, this name would officially take precedence. \*

---

\*For more information on these genera and their species, refer to my first book, *Psilocybe Mushrooms & Their Allies* (1978).

---

## *Hypholoma capnoides* (Fries) Quelet

**Introduction:** Before the publication of my first book, I had a long term affection for this mushroom but never attempted eating it until Elsie Coulter of Hayden Lake, Idaho first told me that *H. capnoides* was her favorite edible mushroom. When a person with the depth of knowledge of an Elsie Coulter tells you a mushroom is her choice edible, you better listen!

A true saprophyte, *H. capnoides* is an aggressive conifer stump decomposer. One precaution is in order. *Hypholoma capnoides* is not a mushroom for those unskilled in mushroom identification. Several poisonous mushrooms resemble this mushroom and inhabit the same ecological niche. I can imagine how overly enthusiastic mycophiles, in their lust for delectable fungi, could mistake *Galerina autumnalis*, a deadly poisonous mushroom sharing the same habitat, for *H. capnoides*. Cultivators should be forewarned that several mushroom species, inoculated or not, can inhabit a single stump or log. This danger is entirely avoided by honing identification skills, or by growing *H. capnoides* indoors on sterilized sawdust/chips.

**Common Names:** The Brown Gilled Clustered Wood Lover  
Smoky Gilled Hypholoma  
Elsie's Edible

**Taxonomic Synonyms & Considerations:** *Hypholoma capnoides* is known by many as *Naematoloma capnoides* (Fr.) Karst. A sister species to *H. capnoides* is *Hypholoma fasciculare* (Hudson ex Fr.) Kummer (= *Naematoloma fasciculare* (Fr.) Quelet), well worth knowing since it is poisonous! These two mushrooms are sometimes difficult to tell apart until the mushrooms are up-turned and the gills are examined. *H. capnoides* has smoky brown gills whereas *H. fasciculare* has gills that are bright greenish yellow to dingy yellow in age. Furthermore, *H. fasciculare* is extremely bitter flavored whereas *H. capnoides* is mild. Once studied, these two species can be separated without difficulty.

**Description:** Cap orange to orangish yellow to orangish brown to dull brown, 2-7 cm. broad at maturity. Convex with an incurved margin, soon expanding to broadly convex to almost flattened,

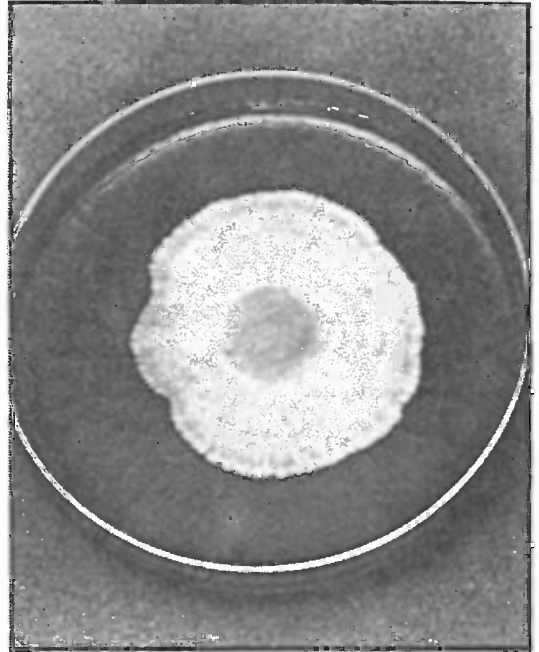

Figure 211. Cultured mycelium of *H. capnoides*. Note growth zones.

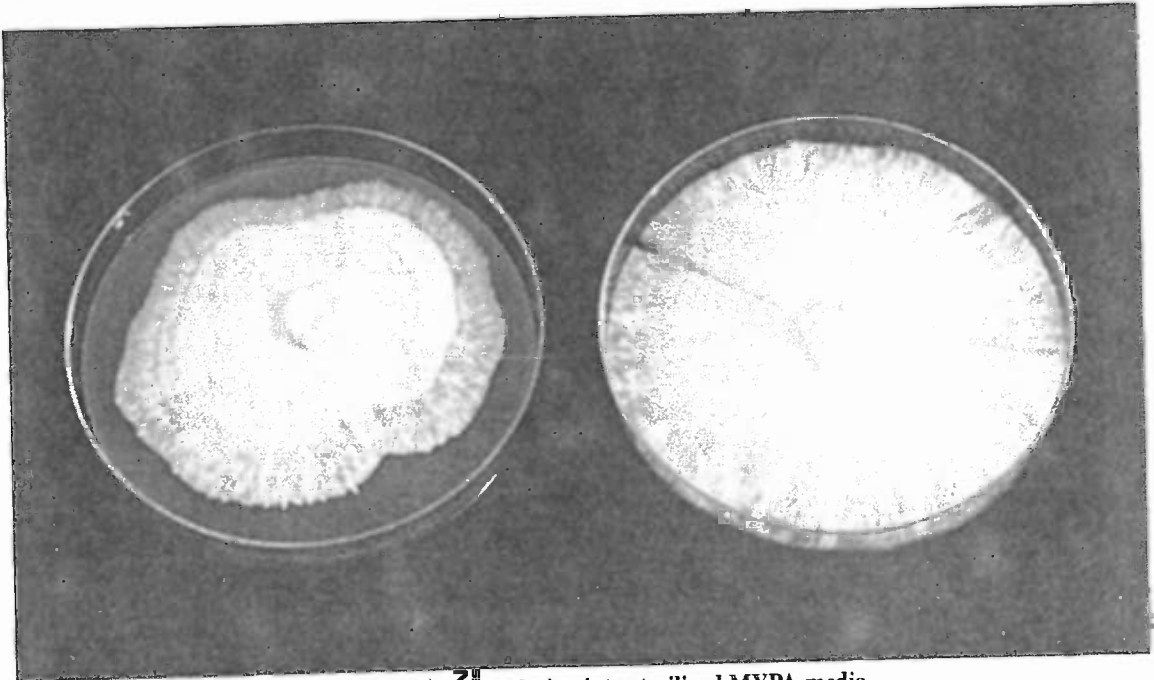

Figure 212. Mycelium 5 and 10 days after inoculation into sterilized MYPA media.

occasionally possessing an obtuse umbilic. Cap margin often adorned with fine remnants of the partial veil, soon disappearing, pale yellowish, becoming buff yellow in age. Surface smooth, moist, and lacking a separable gelatinous skin (pellicle). Gills attached, soon seceding, close, white at first, soon grayish, and eventually smoky grayish purple brown in age. Stem 5-9 cm. long, enlarged at the base, covered with fine hairs. Partial veil cortinate, sometimes leaving a faint annular zone, becoming dusted purple brown with spores on the upper regions of the stem. Usually growing in clusters.

**Distribution:** Widely distributed across North America, particularly common in the western United States. Also found throughout the temperate regions of Europe, probably widely distributed throughout similar ecological zones of the world.

**Natural Habitat:** A lover of conifer wood, especially Douglas fir, this mushroom is frequently found on stumps or logs. I often find this mushroom, along with other interesting relatives, in "beauty bark" used for landscaping around suburban and urban buildings. Although not reported on alder in the wild, I have successfully grown this species on sterilized wood chips of *Alnus rubra*.

**Microscopic Features:** Spores purple brown in mass, 6-7 x 4.0-4.5  $\mu$ , ellipsoid, smooth, with a germ pore at one end. Cheilocystidia, pleurocystidia and clamp connections present. Context monomitic.

**Available Strains:** Strains are easily acquired by cloning the cap context or the flesh adjacent to the pith located at the stem base. Some culture laboratories list this mushroom under the name of *Naematoloma capnoides*.

## Growth Parameters

### Spawn Run:

Incubation Temperature: 70-75° F. (21-24° C.)  
 Relative Humidity: 95-100%  
 Duration: 20-28 days (+ 20 day resting period.)  
 CO<sub>2</sub>: > 10,000 ppm  
 Fresh Air Exchanges: 0-1 per hour.  
 Light Requirements: n/a

### Primordia Formation:

Initiation Temperature: 45-55° F. (7-13° C.)  
 Relative Humidity: 98-100%  
 Duration: 10-14 days.  
 CO<sub>2</sub>: 1000-2000 ppm.  
 Fresh Air Exchanges: 1-2 per hour.  
 Light Requirements: 200-500 lux.

### Fruitbody Development:

Temperature: 50-60° F. (10-16° C.)  
 Relative Humidity: 90-95%  
 Duration: 10-14 days.  
 CO<sub>2</sub>: 1000-5000 ppm  
 Fresh Air Exchanges: 1-2 per hour or as required.  
 Light Requirements: 200-500 lux.

### Cropping Cycle:

2 crops, 4 weeks apart.

---

**Mycelial Characteristics:** Producing a white, silky, rhizomorphic mycelium, usually exquisitely formed, and growing out in distinct zonations. Mycelium becomes overlain with yellow tones in age but not the rusty brown colorations that are typical of *Hypholoma sublateritium*.

**Fragrance Signature:** A fresh, sweet, forest-like, pleasant fragrance, similar to *Stropharia rugoso-annulata*.

**Natural Method of Cultivation:** Using nature as a guide and applying the methods used for *H. sublateritium*, I recommend cultivating this mushroom on stumps. This aggressive species may be one of the best for recycling millions of conifer stumps left in the aftermath of logging. Clusters hosting dozens of fruitbodies and weighing up to four pounds have been collected.

**Recommended Courses for Expansion of Mycelial Mass to Achieve Fruiting:** Nutrified agar into liquid fermentation for 48 hours. (The broth used for fermentation should be fortified with 2-5 grams of sawdust per liter.) Once fermented, the liquid inoculum is transferred into sterilized grain which can be expanded two or three more generations. The grain spawn can inoculate sterilized sawdust/

---



Figure 213. The clustered Woodlover, *Hypholoma capnoides*, growing from a Douglas fir stump.

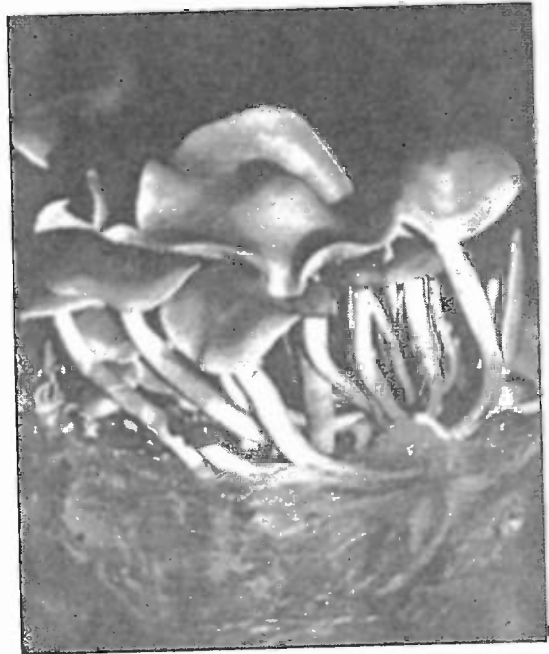

Figure 214. *H. capnoides* fruiting from sterilized hardwood sawdust.

chips, but the spawn rate should not exceed 10% (moist spawn/moist sawdust). The sawdust/chip blocks can be fruited after a resting period, or be used for outdoor planting. The yield of this mushroom is not enhanced by bran-like supplements.

**Suggested Agar Culture Media:** MEA, PDYA, DFA or OMYA.

**1st, 2nd and 3rd Generation Spawn Media:** Grain spawn for the first two generations. Sterilized sawdust is best for the third generation. The sawdust can be fruited or used as spawn for outdoor inoculations.

**Substrates for Fruiting:** Unsupplemented alder, oak, or conifer (Douglas fir) sawdust, chips, logs or stumps.

**Recommended Containers for Fruiting:** Bags, bottles or trays.

**Yield Potentials:** .10-.25 lbs. of mushrooms per 5 lbs. sawdust. Yields should substantially improve with strain development and further experimentation. I have not seen any reports on the cultivation of this mushroom.

**Harvest Hints:** Mushrooms should be harvested when the caps are convex. Since the stems elongate much in the same manner as Enokitake (*Flammulina velutipes*), the harvest method is similar. Out-



doors, this mushroom forms clusters, often with several dozen mushrooms arising from a common base.

**Form of Product Sold to Market:** Not yet marketed.

**Nutritional Content:** Not known to this author.

**Medicinal Properties:** Given this species' woodland habitat and success in combating competitors, I think *H. capnoides* should be carefully examined for its anti-bacterial and medicinal properties.

**Flavor, Preparation & Cooking:** Nutty and excellent in stir fries. See recipes in Chapter 24.

**Comments:** High yielding strains of *Hypholoma capnoides* for indoor cultivation have not yet been developed. I hope readers will clone wild specimens, especially those forming unusually large clusters and screen for commercially viable strains. At present, this mushroom is better grown outdoors than indoors. *Hypholoma capnoides* is one of the few gourmet mushrooms adaptive to cultivation on conifer stumps and logs. Once sawdust spawn is implanted into fresh cuts via wedge or sandwich inoculation techniques, rhizomorphs soon form. Large diameter stumps and logs have been known to produce crops every season for more than a decade. Agri-foresters should carefully consider the judicious use of this fungus in designing polyculture models.

Indoor strategies closely mimic the methods used for Enoki-take: stems elongate in response to elevated carbon dioxide levels and cap development is influenced both by light and carbon dioxide. As a base-line, and until more information is accumulated, I recommend pursuing a parallel cultivation strategy.

---

*Hypholoma sublateritium* (Fries) Quelet

Figure 215. Classic progression of the mycelium of *H. sublateritium*. The mycelium is whitish at first, soon speckled, and eventually rusty brown in color.

**Introduction:** A favorite of Midwest mushroom hunters, great clusters of this species are often found on dead hardwoods, especially stumps, logs, and soils rich in wood debris. The Japanese have pioneered cultivation using techniques similar to Shiitake. *Hypholoma sublateritium* is another excellent candidate for recycling stumps. In Japan, a preferred outdoor method is to inoculate hardwood logs that are then partially buried in shady, natural settings. Fairly productive indoors, this mushroom has yet to be cultivated commercially in North America.

**Common Names:** Kuritake (Japanese for The Chestnut Mushroom)  
Brick Top  
Red Woodlover

**Taxonomic Synonyms and Considerations:** Synonymous with *Naematoloma sublateritium* (Fr.) Karsten.

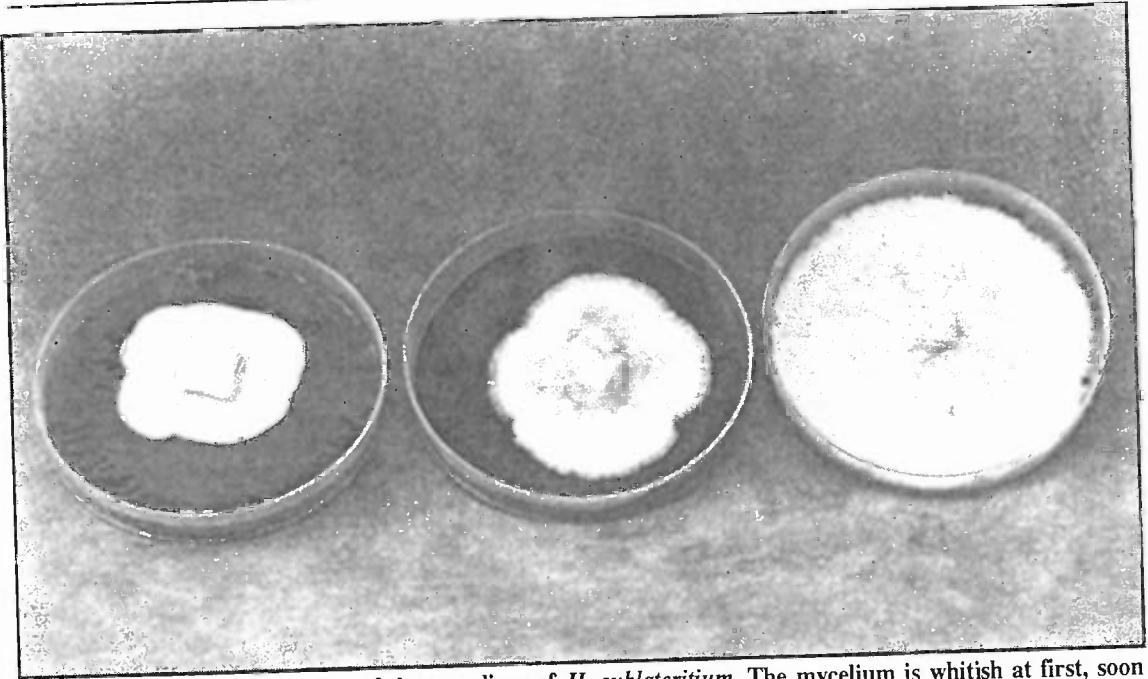
**Description:** Cap 2-7 cm. broad, hemispheric to convex, expanding with age to broadly convex, and eventually plane in age. Cap tan to brown to brick red, darker towards the center, and a lighter yellow near the margin. Margin incurved at first and covered with floccose remnants of the partial veil, soon straightening, and eventually uplifted at maturity. Flesh relatively thick, bruising yellowish. Gills close, bluntly attached to the stem, pallid at first, becoming dark purple gray when mature. Stem 5-10

## Growth Parameters

### Spawn Run:

Incubation Temperature: 70-75° F. (21-24° C.)  
Relative Humidity: 95-100%  
Duration: 20-28 days (+ 14-28 day resting period.)  
CO<sub>2</sub>: > 10,000 ppm.  
Fresh Air Exchanges: 0-1 per hour.  
Light Requirements: n/a

### Primordia Formation:

Initiation Temperature: 50-60° F. (10-16° C.)  
Relative Humidity: 98-100%  
Duration: 8-12 days.  
CO<sub>2</sub>: 1000-2000 ppm.  
Fresh Air Exchanges: 1-2 per hour.  
Light Requirements: 100-200 lux.

### Fruitbody Development:

Temperature: 50-60° F. (10-16° C.)  
Relative Humidity: 90-95%  
Duration: 7-14 days.  
CO<sub>2</sub>: 1000-5000 ppm  
Fresh Air Exchanges: 1-2 per hour or as required.  
Light Requirements: 100-200 lux.

### Cropping Cycle:

2 crops, 2 weeks apart.

---

cm. long x 5-10 mm. thick, solid, and covered with fibrillose veil remnants below the annular zone. This species often forms large clusters.

**Distribution:** Growing in eastern North America, Europe, and temperate regions of Asia (Japan & Korea).

**Natural Habitat:** Fruiting in the late summer and fall, primarily on the stumps of oaks, occasionally chestnut. Dr. Alexander Smith's comments that the largest specimens he found were "at the edge of an old sawdust pile in an oak-hickory woods" and that this species "is a highly prized esculent" should encourage cultivators in their pursuit of outdoor cultivation methods. (Smith (1949), pgs. 509-510.)

**Microscopic Features:** Spores dark gray brown, 6.0-7.5 x 3.5-4.0  $\mu$ , smooth, ellipsoid, with a faint germ pore. Cheilocystidia, pleurocystidia and clamp connections present. Context monomitic.

**Available Strains:** Strains are available from most culture libraries, including several from the American Type Culture Collection. ATCC # 64244 is a good fruiting strain and is featured in this book.

---

**Mycelial Characteristics:** Mycelium white, cottony at first, soon linearly rhizomorphic with a silkish sheen. Soon after colonization of a 100 x 15 mm. MYA petri dish, the mycelium develops zones of tawny or rusty brown discolorations emanating from the site of inoculation and predominating in age. On sterilized sawdust this discoloration immediately precedes primordia formation.

**Fragrance Signature:** Pleasant, sweet, reminiscent of the refreshing fragrance from a newly rained upon forest, similar to the scent of the King Stropharia (*Stropharia rugoso-annulata*).

**Natural Method of Cultivation:** Hardwood logs can be pegged or sawdust inoculated and laid horizontally side by side. Untreated sawdust can be used to bury the logs to 1/3 their diameter. Oak, chestnut, and perhaps the stumps of similar hardwoods can be inoculated using any one of the methods described in this book.

**Recommended Courses for Expansion of Mycelial Mass to Achieve Fruiting:** When a sample of hardwood sawdust is added to the liquid fermentation broth, the mycelium grows more vigorously than without. After 3-4 days of fermentation, the liquid inoculum should be distributed directly into sterilized grain. This grain spawn can be expanded several more generations or used directly for implantation into sterilized, supplemented sawdust. Oak sawdust is preferred. After 50-60 days from inoculation, the substrate can be initiated by lowering temperature to the prescribed levels.

**Suggested Agar Culture Media:** MYPA, OMYA, PDYA or DFA.

**1st, 2nd and 3rd Generation Spawn Media:** Grain spawn throughout, or alternatively sawdust spawn for the 3rd generation. Plug spawn can be created from sawdust spawn.

**Substrates for Fruiting:** Supplemented alder, chestnut, poplar, hickory, cottonwood or oak sawdust, logs and stumps.

**Recommended Containers for Fruiting:** Bottles, bags or trays.

**Yield Potentials:** .25 to .50 lbs. of fresh mushrooms per 5 lbs. of moist supplemented sawdust.

**Harvest Hints:** Cluster formation should be encouraged as well as stem elongation to facilitate harvesting. Clusters can be firmly grasped and the base substrate trimmed off. Mushrooms are better presented as a "cluster bouquet" than individually separated. The brilliant yellowish zone around the cap margin in contrast to the reddish brown color makes this mushroom aesthetically pleasing to the eye.

**Form of Product Sold to Market:** Fresh and dried. Some mycophiles in Midwest prefer to pickle this mushroom. This mushroom, known as Kuritake (the Chestnut Mushroom) in Japan, is primarily marketed in fresh form.

**Nutritional Content:** Not known to this author.

**Medicinal Properties:** Like *H. capnoides*, I believe this mushroom is worthy of investigation for its potential medicinal properties. The only reference I have found is a short note in *Icons of Medicinal Fungi*, which states that "the inhibition rates of *Hypholoma sublateritium* (Fr.) Quel. against sarcoma 180 and Ehrlich carcinoma (sic) is 60% and 70% respectively." (Ying 1987, p.325). The reference supporting this claim is in Chinese and lacks further elaboration.



Figure 216. Inoculated logs of Kuritake, *Hypholoma sublateritium*, fruiting outdoors in a shaded location.

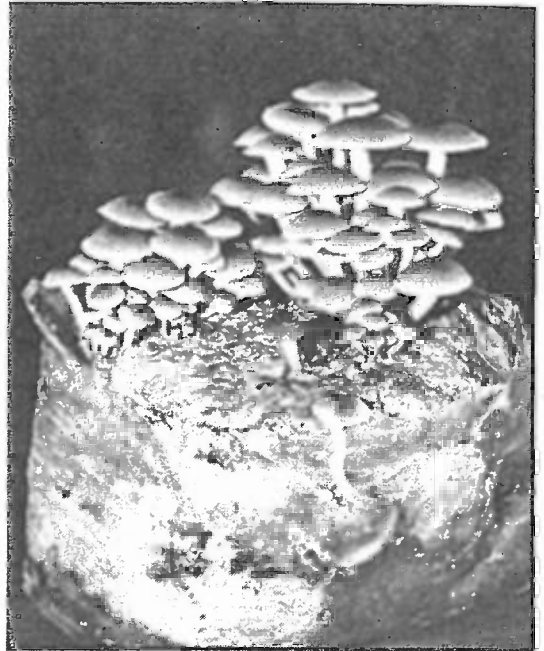

Figure 217. Kuritake fruiting on supplemented alder sawdust/chips.

**Flavor, Preparation & Cooking:** Excellent in stir fries or baked. Many of the recipes listed in this book can incorporate Kuritake.

**Comments:** The cultivation of this mushroom was pioneered at the Mori Mushroom Institute in Kiryu, Japan. Chestnut, oak or similar logs are inoculated with sawdust or plug spawn and partially buried parallel to one another in a shady, moist location.

This mushroom should figure as one of the premier candidates for incorporation into a sustainable model for myco-permaculture. It can be grown indoors on blocks of sterilized sawdust. Once these blocks cease production, they can be buried outside for additional fruitings. Another alternative is that the expired fruiting blocks can be broken apart and the resident mycelium can be used as sawdust spawn for implantation into stumps and logs.

Alexander H. Smith in *Mushrooms in Their Natural Habitats* (1949) notes that some strains of this species from Europe have been implicated in poisonings. I have seen no other reference to this phenomenon in North America or Japan, where this mushroom has long been enjoyed as a favorite edible. Nor have I heard of any recent reports that would suggest alarm.

## The Beech Mushrooms (*Bunashimeji* and *Shirotamogitake*) of the Genus *Hypsizygos*

The rich flavor of the Shimeji mushroom can be summed up by the Japanese phrase "for fragrance, Matsutake; for flavor, Shimeji". However, the name "Shimeji" is widely used to describe some of the best Japanese gourmet mushrooms that grow "on wet ground". For years, the general name Shimeji has been assigned to about 20 mushroom species, causing widespread confusion amongst amateur and professional mycologists.

Recently, a number of scientific articles have attempted to clarify what is the "true Shimeji" which the Japanese call Hon-shimeji. (See Clemencón & Moncalvo (1990); Nagasawa & Arita (1988)). The Hon-shimeji of Japan is actually a *Lyophyllum*, i. e. *Lyophyllum shimeji* (Kawam.) Hongo. This species is not commercially cultivated, and according to researchers at the Mori Mushroom Institute, may even be a mycorrhizal species. \* (Motohashi, 1993). The confusion is understandable because young specimens of *Lyophyllum shimeji* look very similar to *Hypsizygos tessulatus*, known in Japan as Buna-shimeji or the Beech Mushroom.

The Genus *Hypsizygos* was first described by Rolf Singer and contains two excellent, edible and choice mushrooms. Collected in the wild by Native Americans (Singer, 1986), these mushrooms are otherwise not well known to other North Americans. Species in this genus are generally saprophytes, but can become "facultative parasites" when trees, particularly elms and beeches, are dying from other diseases. These mushrooms have a tendency to grow high up on the trunks of trees, making the collecting of wild specimens difficult for the unprepared or unathletic. (*Hypsi-* means "on high or aloft" and *-zygos* means "yoke".) Only two species are known in this Genus, *H. tessulatus* (Bull.:Fries) Singer and *H. ulmarius* (Bull.:Fries) Redhead. Both cause a brown rot of hardwoods.

Firmer fleshed than most *Pleurotus* species, *Hypsizygos* mushrooms out-class the Oyster varieties commonly cultivated by North American and European growers in terms of flavor and texture. Here again, the Japanese are credited for first commercially cultivating *Hypsizygos*. Recent Japanese research shows that *H. tessulatus* may be active in retarding tumor growth when consumed. (Ikekawa, 1990). Studies are on-going to more precisely determine their medicinal properties.

The Genus *Hypsizygos* most closely resembles *Lyophyllum* and to a lesser degree *Pleurotus*. These taxa are separated by the following combination of features. First, *Hypsizygos* and *Pleurotus* typically grow on wood, above ground level. *Lyophyllum* grows on the ground, in soils rich in woody debris. Furthermore, *Hypsizygos* species lack numerous granules within the basidia, a feature that is characteristic of members in the Genus *Lyophyllum*. (These granules are siderophilous, i.e. the granules become apparent in acetocarmine, a stain used by mycologists to bring out internal cell features.) *Hypsizygos* spores are small, generally less than 7 microns, and more ovoid in shape compared to the

\* I find it more likely that *L. shimeji* depends upon soil microflora for fruitbody formation in the same manner as *Stropharia rugoso-annulata* than being a mycorrhizal species.

spores of species in the Genus *Pleurotus* whose spores are more cylindrical and greater than 7 microns in length. Otherwise, mushrooms in these three genera closely resemble each other macroscopically, making cultivated mushrooms difficult to differentiate without the use of a microscope. To my eye, *Hypsizygus ulmarius* looks much more like an Oyster mushroom while *Hypsizygus tessulatus* resembles the terrestrially bound *Lyophyllum* species, especially when young.

For cultivators, another notable advantage of *Hypsizygus tessulatus* and *H. ulmarius* over *Pleurotus* species is their much reduced spore load. Oyster mushroom growers in this country might want to follow the lead of the Japanese in switching over to *Hypsizygus* cultivation for the many clear advantages.

### *Hypsizygus tessulatus* (Bulliard: Fries) Singer

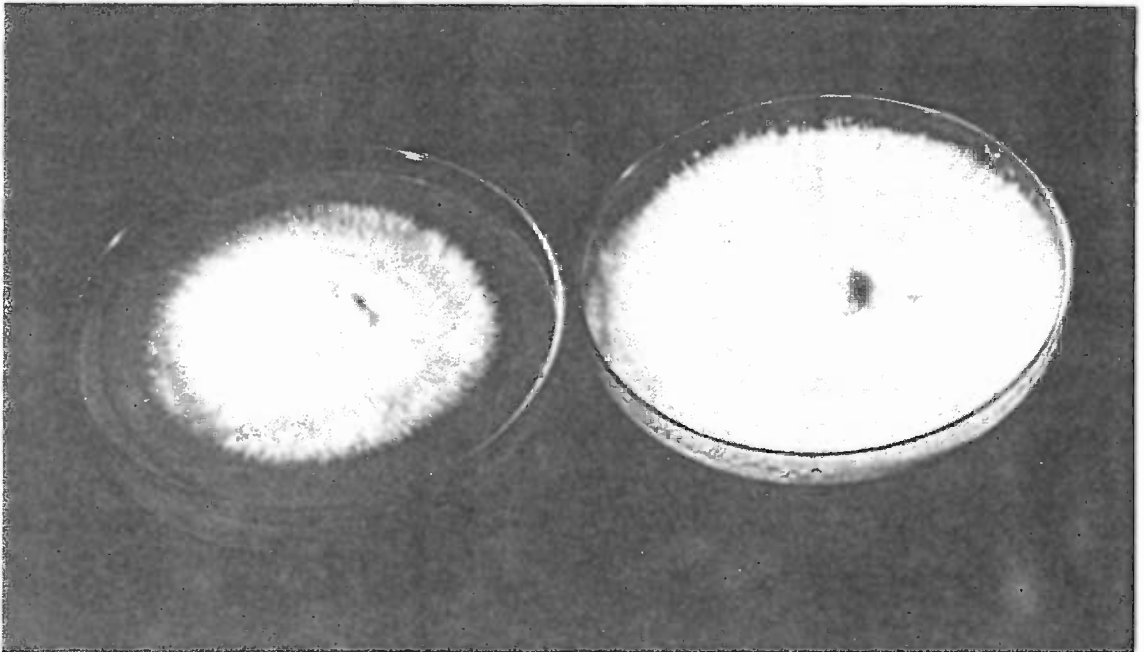

Figure 218. *H. tessulatus* mycelium 4 and 8 days after inoculation onto malt extract agar.

**Introduction:** A delicious species, *H. tessulatus* falls under the umbrella concept of the Japanese “Shimeji” mushrooms. Firm textured, this mushroom is considered one of the most “gourmet” of the Oyster-like mushrooms. Recently, this mushroom has been attributed to having anti-cancer properties. (Ikekawa, 1990). Increasingly better known, this obscure mushroom compares favorably to *P. ostreatus* and *P. pulmonarius* in North American, European and Japanese markets.

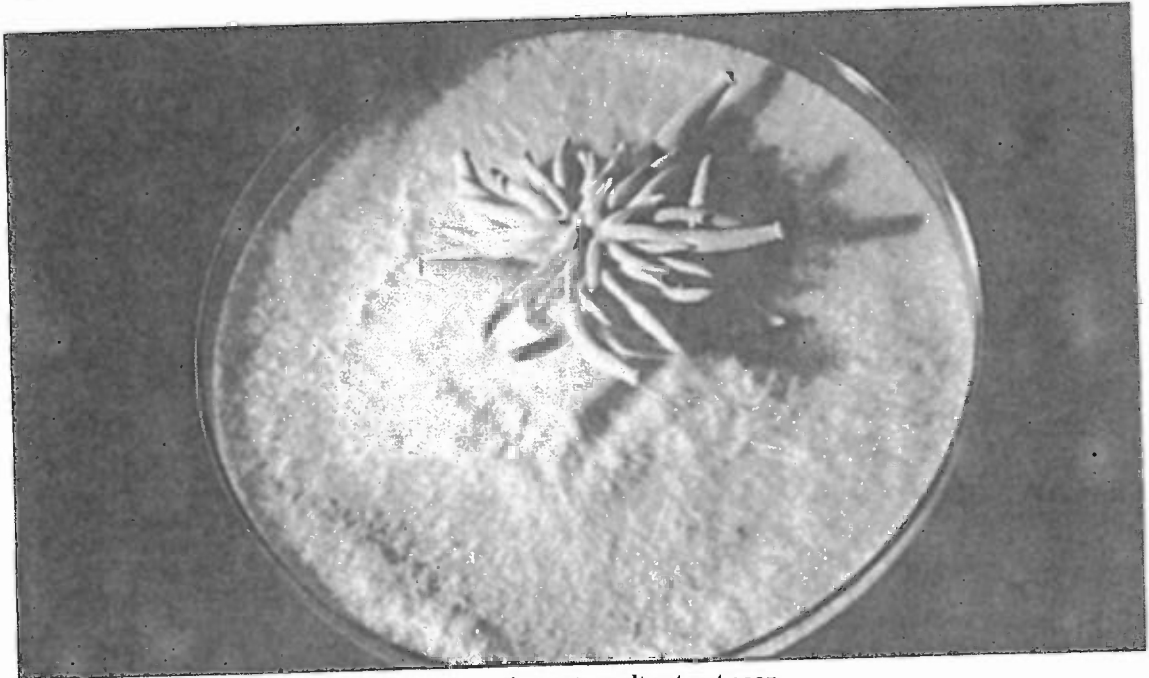

Figure 219. *H. tessulatus* 6 weeks after inoculation onto malt extract agar.

**Common Names:** The Beech Mushroom  
 Buna-shimeji (Japanese for "Beech Mushroom")  
 Yamabiko Hon-shimeji ("Mountain Echo Mushroom")  
 Tamo-motashi ("The Elm Oyster Mushroom")

**Taxonomic Synonyms & Considerations:** The delineation of this species has struggled through a taxonomic quagmire, resulting in a terribly confused history which has only recently been resolved. Originally published by Bulliard as *Agaricus tessulatus* in 1791 from Europe, this collection became the type for a new genus, the Genus *Hypsizygos* as defined by Singer. In 1872, Peck described a paler form as *Agaricus marmoreus* and Bigelow transferred this species to the Genus *Hypsizygos*, naming it *Hypsizygos marmoreus* (Peck) Bigelow.

Redhead (1984) incorrectly proposed synonymy between *H. tessulatus* (Bull. ex. Fries) Singer and *H. ulmarius* (Bull.:Fr.) Redhead which he has since reconciled into two separate, discrete taxa. *Hypsizygos tessulatus* is a synonym of both *Hypsizygos marmoreus* and *Pleurotus elongatipes*, the Long Footed Oyster Mushroom (Redhead 1986), and is not a synonym of *Hypsizygos ulmarius*. Because of the confusion associated with the application of the species name *H. tessulatus*, Japanese mycologists prefer to use the taxonomically "clean" name of *H. marmoreus* (Peck) Bigelow.

The name "tessulatus" refers to the water spots on the caps. "Marmoreus" means marbled, again in reference to the markings on the cap surface. "Elongatipes" refers to the ability of this mushroom to form long stems, especially promoted when the mushroom arises deeply from a cleft or wound in a tree. All these features are clearly expressed when this mushroom is grown indoors.



In Japan, *H. tessulatus* is marketed under the name of “Yamabiko Hon-shimeji” or just “Hon-shimeji”. In the United States, this species is simply marketed under the name “Shimeji”. Adding to the confusion, the name “Buna-shimeji” was first applied by Imazeki to *Lyophyllum ulmarius* (= *H. ulmarius*) but now is used in exclusive reference to *Hypsizygus marmoreus* (= *H. tessulatus*). (See Nagasawa & Arita, 1988.)

**Description:** Mushrooms hemispheric to plane, spotted to marbled with “water-spots” on the cap, measuring 2-7 cm. Cap margin inrolled to incurved when young. Mushrooms dark tan, becoming gray tawny brown to creamy brown when mature. Gills bluntly attached to the stem, close, firm, and “wax-like”. Stem thick, centrally or eccentrically attached, often tapering towards the base, with variable lengths depending on the method of cultivation.

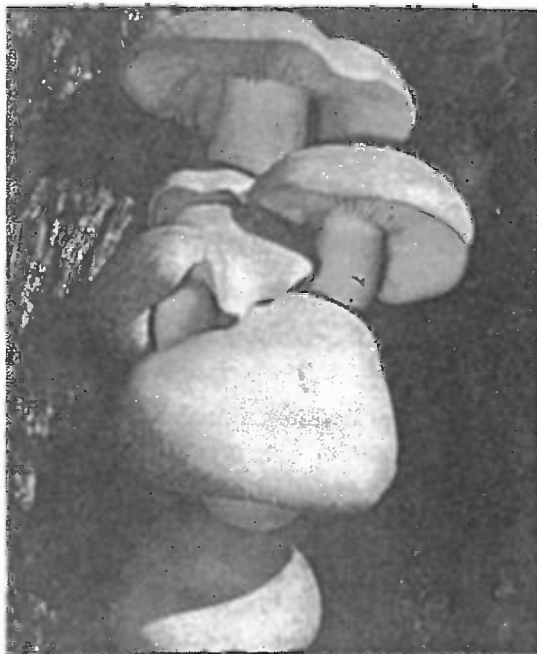

Figure 220. Wild fruiting of *H. tessulatus* from cleft in a cottonwood tree.

**Distribution:** Throughout the temperate hardwood forests of Europe, Asia and North America.

**Natural Habitat:** A saprophyte on elms, beech, cottonwoods, maple, willow, oak and other hardwoods. I have found this mushroom arising from clefts in the trunks of dying cottonwoods. Like many Oyster mushrooms, this species can behave either as a facultative parasite on dying hardwoods or a true saprophyte on dead trees. (The wild fruiting featured in Figure 215 is from a dying cottonwood).

**Microscopic Features:** Spores white, spherical to egg-shaped, relatively small, 4.0-6.5 x 3.5-5.0  $\mu$ . Clamp connections numerous. Hyphal system monomitic.

**Available Strains:** Strains are available from Japanese, American and Canadian culture libraries. Strains range from white to grey to black and are typically darker when young and/or when grown under cool conditions. Those who have patented strains of Hon-shimeji could be referring to *H. tessulatus*, *H. ulmarius* or a *Lyophyllum* species, depending on the taxonomic system they were following. Strains are easily cloned from wild specimens. DAOM #190991 is a light colored Canadian strain, one of several strains featured in this book. (See Figure 223). Strains vary in their duration to fruiting, in the color of the mushrooms at maturity and in their response to carbon dioxide levels.

**Mycelial Characteristics:** Mycelium white, cottony, resembling *P. ostreatus* mycelium but not as aerial. Also, the mycelium of *H. tessulatus* does not exude the yellowish-orange metabolite nor does it form the classically thick, peelable mycelium, two features that are characteristic of *Pleurotus* species.

**Fragrance Signature:** Sweet, rich, not anise-like, but oyster-esque, and pleasing.

**Natural Method of Cultivation:** Inoculation of logs or stumps. This mushroom can sometimes be grown outdoors in deep beds (>6 inches) of wood chips. Sawdust spawn is best used for inoculating outdoor beds. When sterilized supplemented sawdust blocks have finished fruiting indoors, I recommend burying the blocks outdoors into sawdust, in shady settings, to promote fall fruitings.

**Recommended Courses for Expansion of Mycelial Mass to Achieve Fruiting:** The path of mycelial expansion that I recommend is to go from agar cultures into liquid fermentation, then into sterilized grain, then to sawdust and finally into supplemented sawdust.

**Suggested Agar Culture Media:** MYPa, PDYA, DFA or OMYA

**1st, 2nd and 3rd Generation Spawn Media:** The first two generations of spawn can be grain. The third generation can be sawdust or grain.

**Substrates for Fruiting:** Supplemented sawdust. Good wood types are cottonwood, willow, oak, alder, beech, or elm. The effectiveness of other woods has not yet been established. From my experience, straw does not provide commercially viable crops unless inoculated up to 25% of its weight with sawdust spawn.

**Recommended Containers:** Bottles or narrowly opened bags are generally preferred so that stem elongation can be encouraged. Open bag culture results in squat looking mushrooms.

**Yield Potentials:** 1/2 lb. of fresh mushrooms per 5 lb. blocks (wet weight) of supplemented hardwood sawdust/chips.

**Harvest Hints:** This mushroom is "waxy" when young, firm, and deliciously edible. The firmness of the flesh is gradually lost as the mushrooms enlarge. Mushrooms are best picked when the caps are still convex and the margin remains incurved.

**Form of Product Sold to Market:** Fresh, dried & powdered. Extracted fractions for cancer treatment may be available in the near future.

**Nutritional Content:** Not known.



Figure 221 and 222. Bottle culture of *H. tessulatus* (as *H. marmoreus*) in Japan. Note marbled caps, sometimes referred to as "water spots" by mycologists.

## Growth Parameters

### Spawn Run:

Incubation Temperature: 70-75° F. (21-24° C.)  
Relative Humidity: 95-100%  
Duration: 30-45 days  
CO<sub>2</sub>: > 5000 ppm  
Fresh Air Exchanges: 0-1 per hour.  
Light Requirements: n/a

### Primordia Formation:

Initiation Temperature: 50-60° F. (10-15° C.)  
Relative Humidity: 98-100%  
Duration: 7-12 days  
CO<sub>2</sub>: 500-1000 ppm  
Fresh Air Exchanges: 4-8 per hour  
Light Requirements: 500-600 lux.

### Fruitbody Development:

Temperature: 55-65° F. (13-18° C.)  
Relative Humidity: (85) 90-95%  
Duration: 5-10 days  
CO<sub>2</sub>: 2000-4000 ppm  
Fresh Air Exchanges: 2-4 per hour  
Light Requirements: 400-600 lux.

### Cropping Cycle:

Two crops, three weeks apart.

---

**Medicinal Properties:** An unpublished report from the National Cancer Institute of Japan by Ikekawa (1990) showed strong anti-tumor activity. Mice were implanted with Lewis Lung carcinoma and given aqueous extracts of the fresh mushrooms. At a dose equivalent to 1 gram/kilogram of body weight per day, tumors were 100% inhibited, resulting in total regression. Control groups confirmed that, in absence of the mushroom extract, tumors were uninhibited in their growth. No studies with human subjects have been reported.

**Flavor, Preparation & Cooking:** A superior edible mushroom with a firm, crunchy texture and mildly sweet nutty flavor, this mushroom is highly esteemed in Japan. Versatile and enhancing any meal, *H. tessulatus* goes well with vegetable, meat, or seafood stir-fries and can be added to soups or sauces at the last minute of cooking. The flavor dimensions of this mushroom undergo transformations difficult to describe. Buna-shimeji can be incorporated into a broad range of recipes.

---



Figure 223. Bag culture of Buna-shimeji on supplemented alder sawdust and chips.

of product. From a cultivator's point of view, this cultivation strategy is well merited, although the mushrooms look quite different from those found in nature. This cultivation strategy is probably the primary reason for the confused identifications. When visiting Japan, American mycologists viewed these abnormal forms of *H. tessulatus*, a mushroom they had previously seen only in the wild, and suspected they belonged to *Lyophyllum*. (Lincoff (1993)).

Many of the strains of *H. marmoreus* cultivated in Japan produce dark gray brown primordia with speckled caps. These mushrooms lighten in color as the mushrooms mature, becoming tawny or pale woody brown at maturity. All the strains I have obtained from cloning wild specimens of *H. tessulatus* from the Pacific Northwest of North America are creamy brown when young, fading to a light tan at maturity, and have distinct water-markings on the caps. The differences I see may only be regional in nature.

Although we now know that *Hon-shimeji* (i.e. true Shimeji) is not *H. tessulatus*, but is *Lyophyllum shimeji* (Kwam.) Hongo, habits in identification are hard to break. Many Japanese, when referring to cultivated Hon-shimeji, are in fact thinking of *H. tessulatus*.

This mushroom does not exude a yellowish metabolite from the mycelium typical of *Pleurotus* species. However, Petersen (1993) has found that *H. tessulatus* produces a mycelium-bound toxin to nematodes, similar to that present in the droplets of *P. ostreatus* mycelium. This discovery may explain why I have never experienced a nematode infestation in the course of growing *Hypsizygus tessulatus*.

Comments: A quality mushroom, Buna-shimeji is popular in Japan and is being intensively cultivated in the Nagano Prefecture. The only two mushrooms which come close to this species in over-all quality are *H. ulmarius* or *Pleurotus eryngii*.

In the same environment ideal for Shiitake (i.e. normal light, CO<sub>2</sub> less than 1000 ppm), my strains of *H. tessulatus* produce a stem less than 2 inches tall and a cap many times broader than the stem is long. When I reduce these light and elevate carbon dioxide levels, the mushrooms metamorphosize into the form preferred by the Japanese. Here again, the Japanese have set the standard for quality.

In the growing room, abbreviated caps and stem elongation is encouraged so that forking bouquets emerge from narrow mouthed bottles. Modest light levels are maintained (400 lux) with a higher than normal carbon dioxide levels (>2000 ppm.) to promote this form

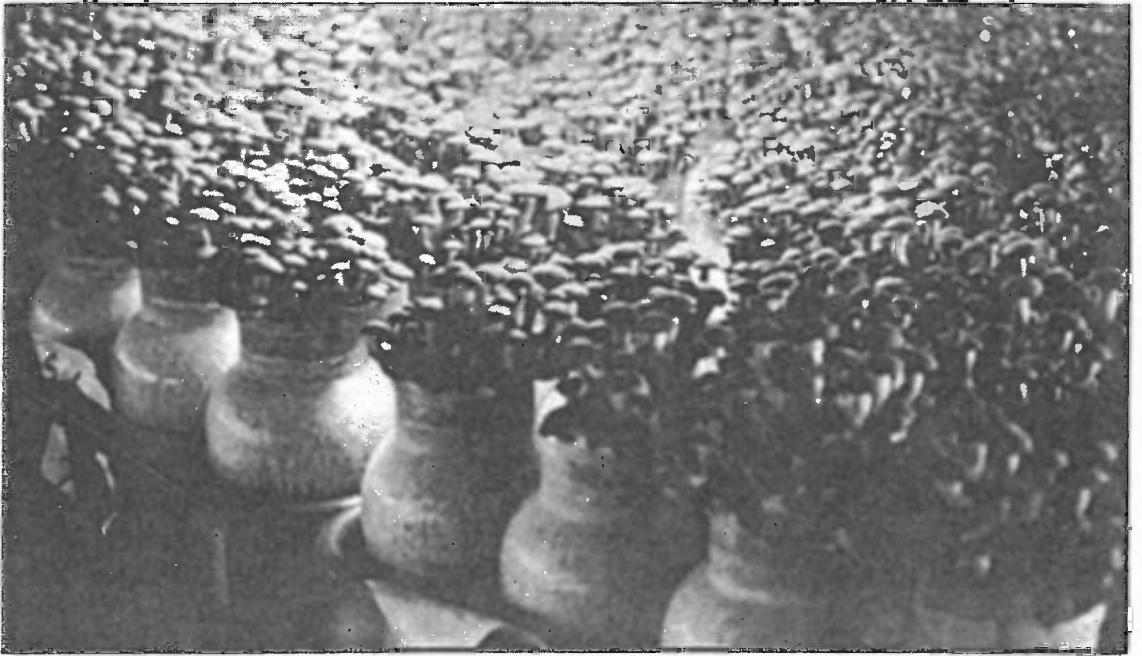

Figure 224. Commercial cultivation of *H. tessulatus* (= *H. marmoreus*) in Japan.

Given the number of potentially valuable by-products from cultivating this mushroom, entrepreneurs might want to extract the water soluble anti-cancer compounds and/or nematacides before discarding the waste substrate.

For more information, consult Zhuliang & Chonglin (1992) and Nagasawa & Arita (1988).

*Hypsizygus ulmarius* (Bulliard: Fries) Redhead

Figure 225. *H. ulmarius* mycelia at 4 and 8 days on malt yeast agar media.

**Introduction:** A relatively rare mushroom which usually grows singly or in small groups on elms and beech, *Hypsizygus ulmarius* closely parallels the morphology of an Oyster mushroom but is far better in flavor and texture. Unique microscopic features qualify its placement into the Genus *Hypsizygus*. Increasingly popular in Japan, *H. ulmarius* has yet to be cultivated commercially in North America where I believe it would be well received by discriminating markets. This mushroom can become quite large.

**Common Names:** The Elm Oyster Mushroom  
Shirotamogitake (Japanese for "White Elm Mushroom")

**Taxonomic Synonyms & Considerations:** An Oyster-like mushroom, *Pleurotus ulmarius* (Bull.: Fr.) Kummer, became *Lyophyllum ulmarium* (Bull.: Fr.) Kuhner and is most recently placed as *Hypsizygus ulmarius* (Bull.: Fr.) Redhead. *H. ulmarius* and *H. tessulatus* are closely related, living in the same ecological niche. *Hypsizygus ulmarius* is not as common, but much larger, lighter in color, and has a flared, thin, uneven and wavy margin at maturity. *H. ulmarius* is similar to an Oyster mushroom in form. *H. tessulatus* is smaller, stouter, with a thicker stem and a cap that is speckled with dark "water" markings. To my eye, *H. tessulatus* is closer in form to a *Lyophyllum* or a *Tricholoma* while *H. ulmarius* looks more like a *Pleurotus*. (Please refer to the taxonomic discussion of *H. tessulatus* on page 248).

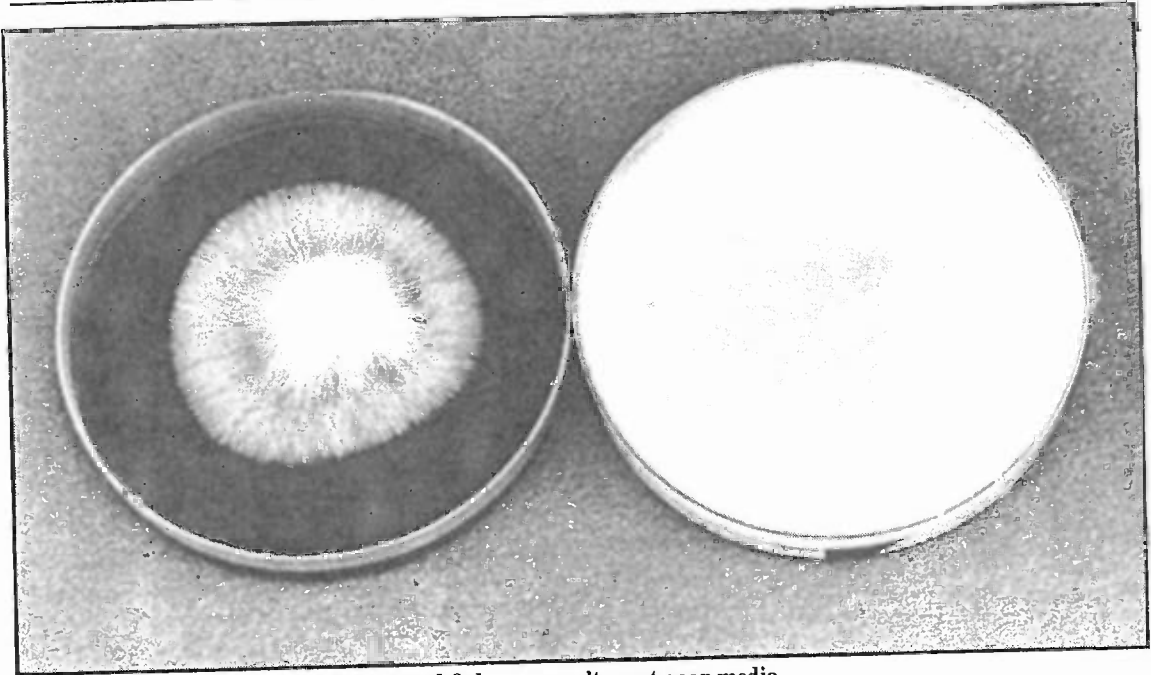
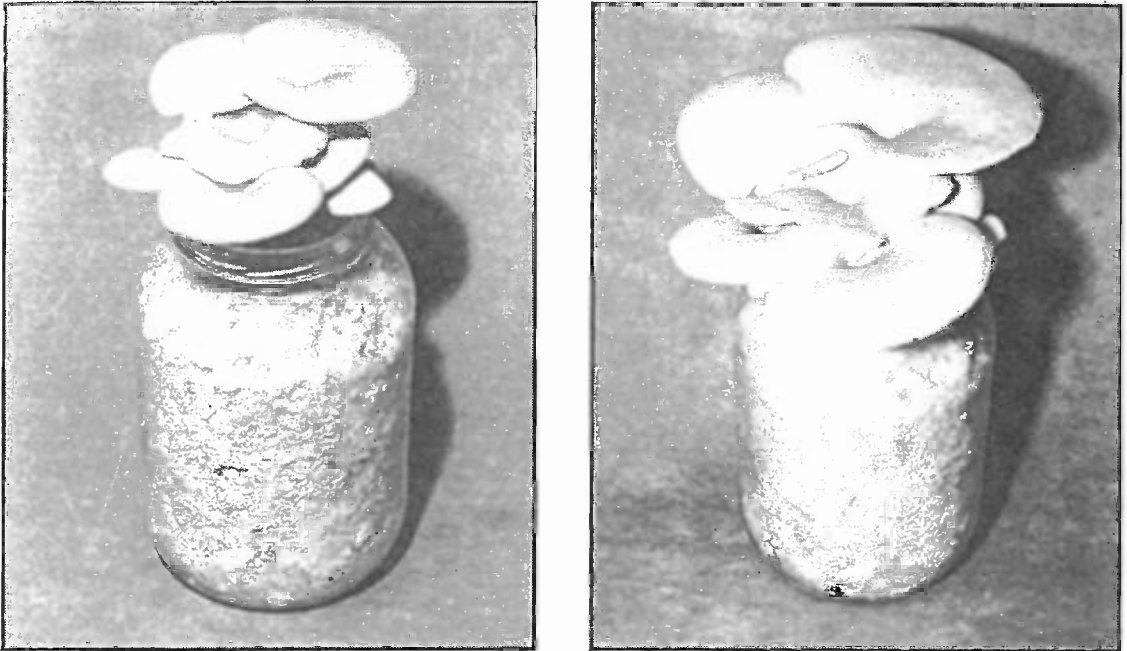

Figures 226 and 227. *H. ulmarius* Day 35 and 36 after inoculation into a gallon jar containing sterilized, supplemented alder sawdust/chips.

**Description:** Mushrooms hemispheric to plane, sometimes umbellicate, uniformly tan, beige, grayish brown, to gray in color, sometimes with faint streaks, and measuring 4-15 cm. Cap margin inrolled to incurved when young, expanding with age, even to slightly undulating. Gills decurrent, close, often running down the stem. Stem eccentrically attached, thick, tapering and curved at the base. Usually found singly, sometimes in groups of two or three, rarely more.

**Distribution:** Throughout the temperate forests of eastern North America, Europe, and Japan. Probably widespread throughout similar climatic zones of the world.

**Natural Habitat:** A saprophyte on elms, cottonwoods, beech, maple, willow, oak and occasionally on other hardwoods.

**Microscopic Features:** Spores white, spherical to egg-shaped, 3-5  $\mu$ . Clamp connections numerous. Hyphal system monomitic.

**Available Strains:** Strains are available from Japanese, American & Canadian culture libraries. The strain featured in this book originated from Agriculture Canada's Culture Collection, denoted as DAOM #189249, produces comparatively large fruitbodies. (See Figure 228). Patents have been awarded, both in Japan and in the United States, to a Japanese group for a particular strain of *H. ulmarius*, which produces a "convex cap".\* (See Kawaano, et al., 1990.) The method of cultivation

\* A mushroom strain producing a convex cap is hardly unusual, let alone patentable. During their life cycle, most gilled mushrooms progress from a hemispheric cap, to one that is convex, and eventually to one that is plane with age.



Figure 228. *H. ulmarius* fruiting from bag of sterilized sawdust.

described in the patent appears the same as for the cultivation of *H. tessulatus*, *Flammulina velutipes* and *Pleurotus* species. Patenting a mushroom strain because it produces a convex cap would be like trying to patent a tree for having a vertical trunk, or a corn variety for producing a cylindrical cob.

**Mycelial Characteristics:** Mycelium white, cottony, closely resembling *P. ostreatus* mycelium. A few strains produce primordia on 2% MYA media.

**Fragrance Signature:** Sweetly oystersque with a floury overtone, not anise-like, but pleasant.

**Natural Method of Cultivation:** Inoculation of partially buried logs or stumps. I suspect that this mushroom will probably grow in outdoor beds consisting of a 50:50 mixture of hardwood sawdust and chips, much like the King Stropharia.

**Recommended Courses for Expansion of Mycelial Mass to Achieve Fruiting:** This mushroom adapts well to the liquid fermentation methods described in this book.

**Suggested Agar Culture Media:** MYP A, PDYA, OMYA or DFA.

**1st, 2nd and 3rd Generation Spawn Media:** Grain spawn throughout. For outdoor cultivation, sawdust spawn is recommended. Supplementing sterilized sawdust definitely enhances mycelial integrity and yields.

**Substrates for Fruiting:** Oak, alder, or cottonwood sawdust supplemented with rye, rice, or wheat bran is preferred. I have had good results using the production formula of alder sawdust/chips/bran.



## Growth Parameters

### Spawn Run:

Incubation Temperature: 70-80° F. (21-27° C.)

Relative Humidity: 95-100%

Duration: 14-21 days, + 7 day rest

CO<sub>2</sub>: > 10,000 ppm

Fresh Air Exchanges: 0-1

Light Requirements: n/a

### Primordia Formation:

Initiation Temperature: 50-55° F. (10-13° C.)

Relative Humidity: 98-100%

Duration: 5-10 days.

CO<sub>2</sub>: < 1000 ppm

Fresh Air Exchanges: 4-8 per hour or as needed

Light Requirements: 500-1000 lux

### Fruitbody Development:

Temperature: 55-65° F. (13-18° C.)

Relative Humidity: (90) 94-98%

Duration: 4-7 days

CO<sub>2</sub>: 600-1500 ppm

Fresh Air Exchanges: 4-8 per hour or as needed.

Light Requirements: 500-100 lux.

### Cropping Cycle:

Two crops, 7-10 days apart.

---

**Recommended Cropping Containers:** Polypropylene, autoclavable bags, bottles, and/or trays. This mushroom grows well horizontally or vertically.

**Yield Potentials:** My yields consistently equal 1/2-1 lb. of fresh mushrooms from 5 lbs. of moist sawdust/chips/bran.

**Harvest Hints:** I especially like this mushroom when it grows to a fairly large size, but prior to maximum sporulation. I gauge the thickness at the disc as the criterion for harvesting, preferring at least 2 inches of flesh.

**Form of Product Sold to Market:** Fresh, sold only in Japan and Taiwan at present.

**Nutritional Content:** Not known to this author.

**Medicinal Properties:** I know of no published studies on the medicinal properties of *Hypsizygus ulmarius*. Anecdotal reports, unpublished, suggest this mushroom is highly anti-carcinogenic. Much

---

of the research has been done in Japan. Mushrooms in this group, from the viewpoint of traditional Chinese medicine, are recommended for treating stomach and intestinal diseases.

**Flavor, Preparation & Cooking:** The same as for most Oyster mushrooms. See recipes.

**Comments:** *Hypsizygus ulmarius* is an excellent edible ranking, in my opinion, above all other Oyster-like mushrooms. I find the texture and flavor of a fully developed *H. ulmarius* mushroom far surpasses that of the even the youngest specimens of *Pleurotus ostreatus* or *Pleurotus pulmonarius*. Oyster mushroom cultivators throughout the world would do well to experiment with this mushroom and popularize it as an esculent.

This mushroom is extraordinary for many reasons. When the caps grow to the broadly convex stage, lateral growth continues, with an appreciable increase in mass. (In most cultivated mushrooms, when the cap becomes broadly convex, this period signifies an end to an increase in biomass, and marks the beginning of re-apportionment of tissue for final feature development, such as gill extension, etc.) If cultivators pick the mushrooms too early, a substantial loss in yield results. Not only is *H. ulmarius*' spore load substantially less than most *Pleurotus* species, but the quality of its fruitbody far exceeds *P. ostreatus*, *P. pulmonarius*, *P. djamor*, *P. cornucopiae* and allies. In my opinion, only *P. eryngii* and *H. tessulatus* compare favorably with *H. ulmarius* in flavor and texture.

---

---

## The Shiitake Mushroom of the Genus *Lentinula*

Shiitake mushrooms (pronounced (*shee ta' kay*) are a traditional delicacy in Japan, Korea and China. For at least a thousand years, Shiitake mushrooms have been grown on logs, outdoors, in the temperate mountainous regions of Asia. To this day, Shiitakes figure as the most popular of all the gourmet mushrooms. Only in the past several decades have techniques evolved for its rapid cycle cultivation indoors, on supplemented, heat-treated sawdust-based substrates.

Cultivation of this mushroom is a centerpiece of Asian culture, having employed thousands of people for centuries. We may never know who actually first cultivated Shiitake. The first written record of Shiitake cultivation can be traced to Wu Sang Kwuang who was born in China during the Sung Dynasty (960-1127 AD). He observed that, by cutting logs from trees which harbored this mushroom, more mushrooms grew when the logs (were soaked and struck". (See Figures 24 & 25). In 1904, the Japanese researcher Dr. Shozaburo Mimura published the first studies of inoculating logs with cultured mycelium. (Mimura, 1904; Mimura, 1915). Once inoculated, logs produce six months to a year later. With the modern methods described here, the time period from inoculation to fruiting is reduced to only a few weeks.

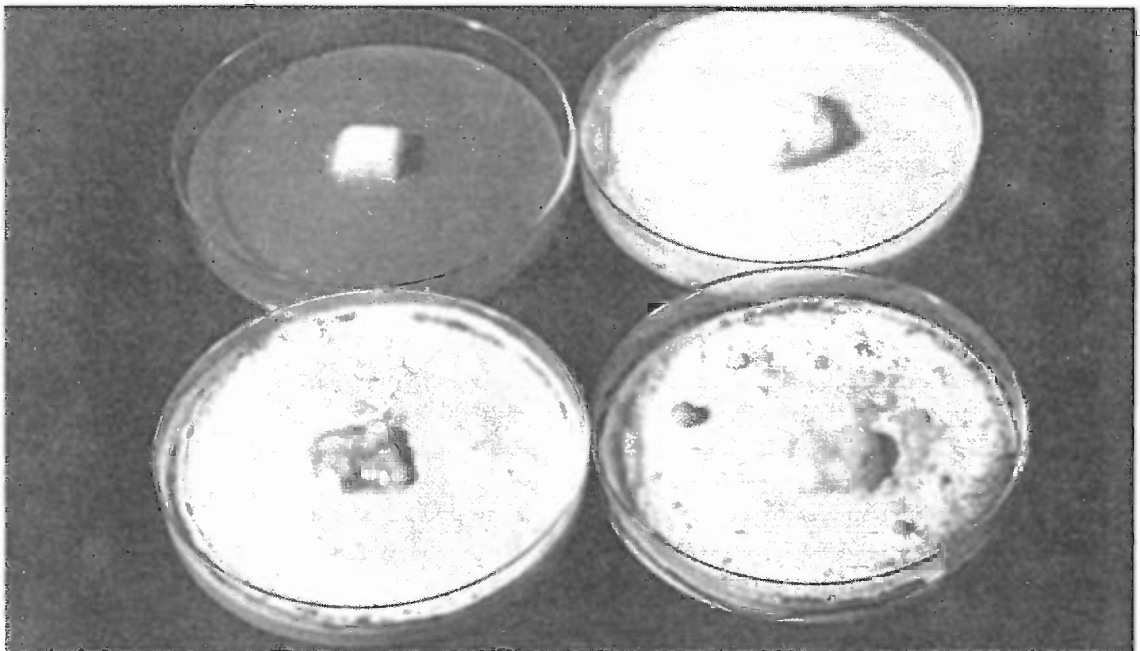

Figure 229. Mycelium of *L. edodes* 2, 10, 20 and 40 days after inoculation onto malt extract agar (MEA) media.

*Lentinula edodes* (Berkeley) Pegler

Figure 230. Mycelia of *L. edodes* 25 and 40 days after inoculation onto sterilized malt extract agar media. Note formation of hyphal aggregates in the culture on the left. This is a strain specific phenomenon and usually indicates vigor. The culture at the right shows browning reaction of the outer-edge mycelium. This coloration change as the mycelium ages is typical of Shiitake.

**Introduction:** Log culture, although traditional in Asia, has yet to become highly profitable in North America —despite the hopes of many woodlot owners. However, log culture does generate modest supplementary income and fits well within the emerging concept of mycopermaculture.

In contrast, indoor cultivation on sterilized sawdust-based substrates is proving to be highly profitable for those who perfect the technique. Most successful American growers have adapted the methods originating in Asia for the cultivation of this mushroom on sterilized substrates by doubling or tripling the mass of each fruiting block and by “through-spawning”. The Japanese, Taiwanese and Thai production systems typically utilize cylindrically shaped bags filled with 1 kilogram of supplemented sawdust which are top-inoculated. This method gives a maximum of two flushes whereas the more massive blocks (2-3 kilograms apiece) provide 4 or 5 flushes before expiring. The method I have developed, and which is illustrated in this book, gives rise to fruitings within 20-35 days of inoculation, two to three times faster than most cultivators achieve on sterilized substrates. This technique is fully described in the ensuing paragraphs.

**Common Names:** Shiitake (Japanese for “Shii Mushroom”)  
Golden Oak Mushroom

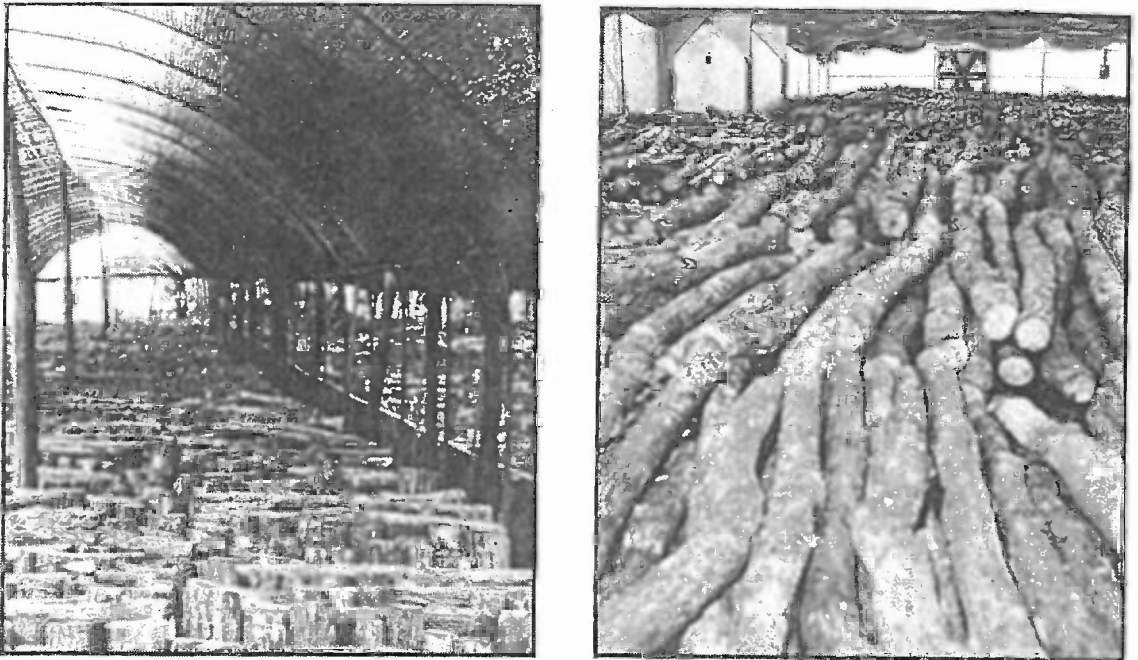

Figure 231 & 232. Oak logs incubating after inoculation with Shiitake plug spawn in uninsulated, shade clothed greenhouses in Japan and in United States.

Black Forest Mushroom  
 Black Mushroom  
 Oakwood Mushroom  
 Chinese Mushroom  
 Shiangu-gu or Shiang Ku (Chinese for "Fragrant Mushroom")  
 Donku  
 Pasania

**Taxonomic Considerations:** Shiitake mushrooms were originally described as *Agaricus edodes* by Berkeley in 1877. Thereupon the mushroom has been variously placed in the Genera *Collybia*, *Armillaria*, *Lepiota*, *Pleurotus* and *Lentinus*. Most cultivators are familiar with Shiitake as *Lentinus edodes* (Berk.) Singer. Shiitake has recently been moved to the Genus *Lentinula* by Pegler

The Genus *Lentinula* was originally conceived by Earle in the early 1900's and resurrected by Pegler in the 1970's to better define members formerly placed in *Lentinus*. Both genera are characterized by white spores, centrally to eccentrically attached stems, gill edges which are often serrated, and a distinct preference for woodland environments. The genera differ primarily in microscopic features. The Genus *Lentinula* is monomitic, i.e. lacking dimitic hyphae in the flesh, and have cells fairly parallel and descending in their arrangement within the gill trama. Members in the Genus *Lentinus* have a flesh composed of dimitic hyphae and have highly irregular or interwoven cells in the gill trama.



Figure 233. Logs are bundled prior to immersion in water.

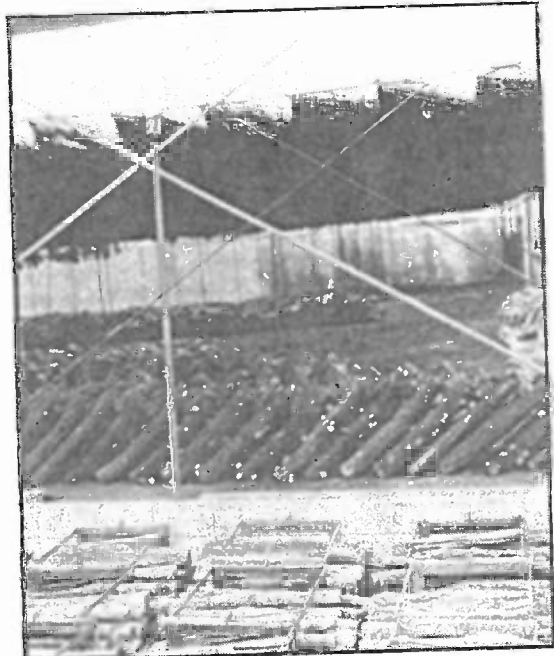

Figure 234. A trough, pond, or in this case, a brick framed pool (foreground) is used for immersing logs into water for 1-2 days to stimulate fruiting.

In 1975, Pegler proposed this species be transferred to *Lentinula*. Although Singer has disagreed with this designation, many taxonomists concur with Pegler. (Redhead, 1993). Pegler believes Shiitake is more closely allied to the genera like *Collybia* of the Tricholomataceae family than to mushrooms like *Lentinus tigrinus*, the type species of the Genus *Lentinus*. Furthermore, *Lentinus* shares greater affinities to genera of the Polyporaceae family where it is now placed rather than to other gilled mushrooms. This allegiance bewilders most amateur mycologists until the mushrooms are compared microscopically. Recent DNA studies support this delineation. Cultivators must keep abreast of the most recent advances in taxonomy so that archaic names can be retired, and cultures be correctly identified. For more information, consult Hibbett & Vilgalys (1991), Singer (1986), Redhead (1985), Pegler (1975 & 1983).

**Description:** Cap 5-25 cm. broad, hemispheric, expanding to convex and eventually plane at maturity. Cap dark brown to nearly black at first, becoming lighter brown in age, or upon drying. Cap margin even to irregular, inrolled at first, then incurved, flattening with maturity and often undulating with age. Gills white, even at first, becoming serrated or irregular with age\*, white, bruising brown when damaged. Stem fibrous, centrally to eccentrically attached, fibrous, and tough in texture. Flesh bruises brownish.

\* Although taxonomists frequently refer to the even margin of Shiitake, as a grower, I see the Shiitake gill margins progressing from even to irregular edges as the mushrooms mature, especially on the first flush. I would hesitate to rely on this feature as one of taxonomic significance. It may be a strain-determined phenomenon.

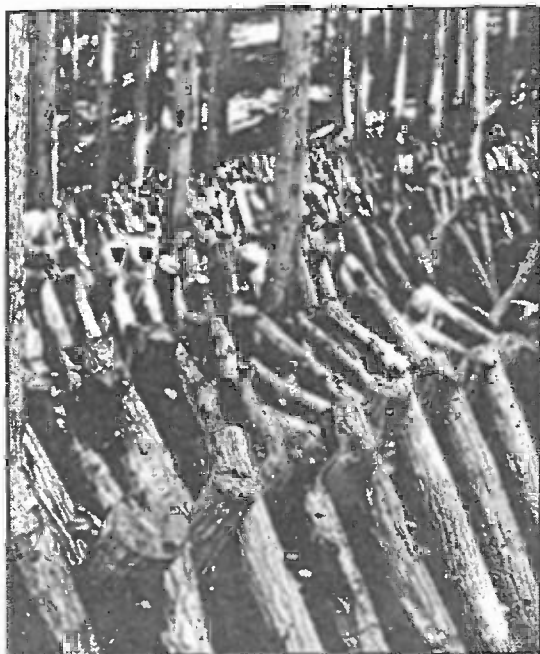

Figure 235. After soaking, logs can be placed into a young conifer forest which provides shade and helps retain humidity. Logs are watered via sprinklers two to four times a day. Mushrooms appear one to two weeks after removal from the soaking pond.

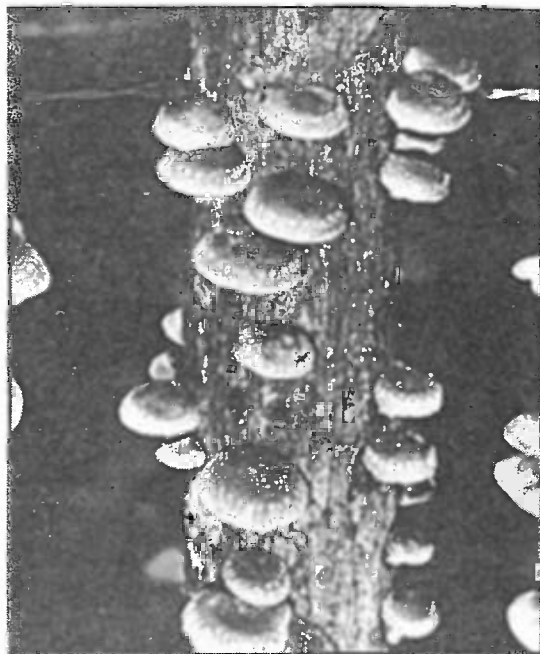

Figure 236. Shiitake forming on oak logs.

**Distribution:** Limited to the Far East, native to Japan, Korea, & China. Not known from North America nor Europe. With the continued deforestation of the Far East, the genome of this mushroom appears increasingly endangered.

**Natural Habitat:** This mushroom grows naturally on dead or dying broad leaf trees, particularly the Shii tree (*Castanopsis cuspidata*), *Pasania* spp., *Quercus* spp. & and other Asian oaks and beeches. Although occasionally found on dying trees, Shiitake is a true saprophyte exploiting only necrotic tissue.

**Microscopic Features:** Spores white 5-6.5 (7) x 3-3.5  $\mu$ , ovoid to oblong ellipsoid. Basidia



Figure 237. Shiitake mushrooms growing on alder logs.

four spored. Hyphal system monomitic. Pleurocystidia absent. Clamp connections and cheilocystidia present.

**Available Strains:** Many strains are available and vary considerably in their duration to fruiting, the formation of the fruitbodies as well as their adaptability to different wood types. ATCC #58742, ATCC #26087 and Mori #465 are all strains which fruit in 10-14 weeks after inoculation onto supplemented sawdust. I have developed a strain, designated Stamets CS-2, which originally came from China and produces in as quickly as 14 days from inoculation onto supplemented alder sawdust! I have found, however, that by forestalling primordia formation until 25-30 days after inoculation, the mycelium achieves greater tenacity, giving rise to better quality fruitbodies. This same strain regularly produces mushrooms 30-40 days after inoculation onto supplemented oak sawdust. Using my methods in combination with this fast-fruiting strain, the Shiitake fruiting cycle is completed in 90 days from the date of inoculation, yielding 4-5 flushes and averaging 2 lbs. of mushrooms per block. The first flush arises from blocks which are totally white in color. Volunteer fruitings on MEA media, on grain, and on sawdust in 3 weeks are characteristic of this strain.

**Mycelial Characteristics:** Mushroom mycelium white at first, becoming longitudinally linear and cottony-aerial in age, rarely, if ever truly rhizomorphic. In age, or in response to damage, the mycelium becomes dark brown. Some strains develop hyphal aggregates—soft, cottony ball-like structures—which may or may not develop into primordia. Many mycologists classify this species as



Figure 238. Shiitake mushrooms growing on oak logs.



Figure 239. Shiitake growing on ironwood logs.





Figure 240. Approximately 20 days after inoculation, the surface topography of Shiitake blisters, a phenomenon many cultivators call "popcorning". The time to blistering is strain specific.



Figure 241. 25 days after inoculation onto sterilized, supplemented alder sawdust, brown primordia form on the peaks of the blisters. When ten mushrooms form, I remove the plastic to allow unencumbered development. Most methods for growing Shiitake on sterilized sawdust require 70-90 days before primordia are visible, and usually only after the blocks have become brown in color.

a white rot fungus for the appearance of the wood after colonization. However, the mycelium of Shiitake is initially white, soon becoming chocolate brown with maturity.

**Fragrance Signature:** Grain spawn having a smell similar to crushed fresh Shiitake, sometimes slightly astringent and musty. Sawdust spawn has a sweeter, fresh and pleasing odor.

**Natural Method of Cultivation:** On hardwood logs, especially oak, sweetgum, poplar, cottonwood, alder, ironwood, beech, birch, willow, and many other non-aromatic, broad-leaf woods. The denser hardwoods produce for as long as six years. The more rapidly decomposing hardwoods have approximately 1/2 the lifespan. The fruit-woods are notoriously poor for growing Shiitake. Although Shiitake naturally occurs on oaks and beeches, the purposeful cultivation of this mushroom on hardwood stumps in North America has had poor success thus far.

For the most current information on the cultivation of Shiitake on logs, see Fujimoto (1989), Przybylowicz & Donoghue (1988), Leatham (1982), Komatsu (1980 & 1982), Kuo & Kuo (1983) and Harris (1986). Several studies on the economics of log cultivation have been published to date. Kerrigan (1982) published a short booklet on the economics of Shiitake cultivation on logs which



Figure 242. Cruz Stamets standing with first flush Shiitake 30 days after inoculation onto sterilized, supplemented alder sawdust/chips.



Figure 243. Janet Bütz examines yet another first flush Shiitake forming from white blocks 35 days after inoculation.

## Growth Parameters

### Spawn Run:

Incubation Temperature: 70-80° F. (21-27° C.)  
 Relative Humidity: 95-100%  
 Duration: 35-70 days (strain dependent)  
 CO<sub>2</sub>: > 10,000 ppm  
 Fresh Air Exchanges: 0-1  
 Light Requirements: 50-100 lux.

### Primordia Formation:

Initiation Temperature: 50-60° F. (10-16° C)\*  
 60-70° F. (16-21° C)\*\*  
 Relative Humidity: 95-100%  
 Duration: 5-7 days  
 CO<sub>2</sub>: <1000 ppm  
 Fresh Air Exchanges: 4-7 per hour  
 Light Requirements: 500-2000 lux at 370-420 nm.

### Fruitbody Development:

Temperature: 50-70° F. (16-18 C)\*  
 60-80° F. (21-27° C)\*\*  
 Relative Humidity: 60-80%  
 Duration: 5-8 days  
 CO<sub>2</sub>: < 1000 ppm  
 Fresh Air Exchanges: 4-8 per hour  
 Light Requirements: 500-2000 lux at 370-420 nm.\*\*\*

### Cropping Cycle:

Every 2-3 weeks for 8-12(16) weeks.

---

sought to show the profitability of Shiitake log culture. Gormanson & Baughman (1987) published an extensive study and concluded that profitability of growing Shiitake outdoors, as in Japan, was marginal at best. Roberts (1988) reviewed their statistical models and concluded that Shiitake cultivation on logs was not profitable. In the most recent study on log Shiitake industry in the United States, Rathke & Baughman (1993) concluded that when a production threshold of 4000 logs/year was achieved by an *experienced* grower, the net profit on money invested, after costs, was a mere 5.76% return after-tax equivalent. Increasing production to 8000 logs had no appreciable increase in profit-

\* Cold weather strains.

\*\* Warm weather strains. Fluctuations of temperatures within these ranges is beneficial to the development of the mushroom crop.

\*\*\* Light levels below 500 lux cause noticeable elongation of the stem with many strains.

---



Figure 244. After each flush, the blocks sit dormant for 7-10 days, after which they are placed into a soaking tank and submerged in water for 24-36 hours.



Figure 245. After submersion, the blocks are spaced well apart and placed onto open-wire shelves. These same blocks on solid shelves would contaminate with green molds.

ability. Joe Deden, who runs Forest Resource Center outside of Lanesboro, Minnesota has been instrumental in matching Shiitake strains with various woods, and bringing Shiitake log cultivation to the forefront of public awareness. With continued refinement of technology, profitability should increase.

Presently, I believe a stand-alone Shiitake log operation can only be profitable if substantial subsidies are provided to offset the costs of materials and labor. However, this is not to say that Shiitake cultivation on logs is not attractive for those seeking minor supplemental income, or for those, who simply enjoy cultivating mushrooms at home for their friends and family. Shiitake cultivation on logs may be a perfect example that "smaller is better".

**Recommended Courses for Expansion of Mycelial Mass to Achieve Fruiting:** Modern methods use a hardwood-based substrate, amended with a nitrogen-rich supplement (rice bran, wheat bran, rye bran, oatmeal, soy flour, etc.). The mixture is moistened and packed into heat tolerant plastic bags, sterilized, and inoculated with either grain or sawdust spawn. The Shiitake bags or "blocks" as they are commonly called are then placed into indoor, controlled environment growing rooms. The first flush is initiated by simply elevating humidity and watering. Subsequent flushes are initiated by submerging the blocks into cold water for 24-36 hours. The fruiting cycle usually spans no more than 3 months from the time of the first flush.

This species adapts well to liquid culture techniques. I prefer to use malt agar media supplemented with 3-5 grams of alder sawdust. Once the cultures are grown out, they are blended in a stirrer, sub-proportioned into Erlenmeyers flasks containing malt sugar, yeast, and alder (2%:.1%: .5% respectively), fermented for two days, and injected into sterilized rye grain. These liquid-inoculated grain masters are then used to inoculate sawdust for the creation of sawdust spawn which can then be used to inoculate the fruiting substrate: sawdust/chips/bran. For further information of Shiitake under liquid culture conditions, see Raaska (1990), Yang & Jong (1987) and Leatham (1983).

**Suggested Agar Media:** PDYA, MYA, and OMYA with the addition of .2% of the hardwood sawdust used in the production block.

**1st, 2nd and 3rd Generation Spawn Media:** Rye, wheat, sorghum or corn throughout for the first two generations. I recommend sawdust spawn for the third and final generation.

**Substrates for Fruiting:** Broad-leaf hardwoods such as oak, ironwood, sweetgum, beech, poplar, cottonwood, and alder.

The formula described on page 162 utilizing sawdust, chips, rice or rye bran, and buffered with gypsum is ideal for high yield, indoor production. At make-up this substrate hovers around 5.5-6.0. Prior to fruiting, the pH drops to 3.5-4.5. (The optimal range for fruiting, according to Chang & Miles (1989) falls between 4.2-4.6). Other recipes utilize a variety of supplements, including various grains, the cereal brans, most flours, tea leaves, yeast, molasses etc. For further information on formulating sawdust-based media, consult Jong (1989), Royse & Bahler (1986), San Antonio (1981) and Ando (1974). The Forest Research Institute of New Zealand published one of the first studies exploring the usefulness of pines (*Pinus radiata*—the Monterey Pine) which produced satisfactorily yields when combined with a hardwood such as beech or poplar and supplemented with barley grain. (The ratio was 6 parts pine: 3 parts hardwood: 1 part grain.)

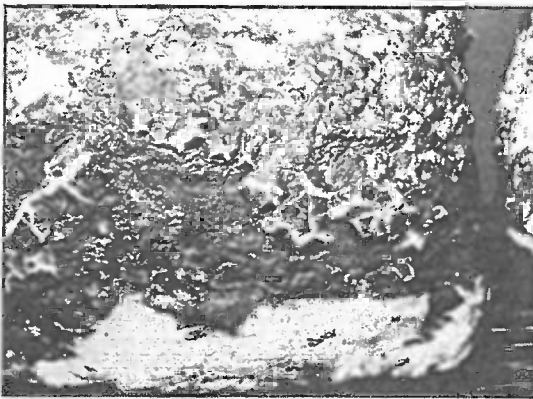

Figure 246. 2-3 days after submersion, mushrooms form below the surface, cracking the outer brown skin.



Figure 247. 4 days from the soak tank, mushrooms visibly extend beyond the surface plane of the sawdust block.



Figure 248. 7 days after submersion, crop is ready for harvest. This process can be repeated 4-5 times before the blocks cease production.

**Recommended Containers for Fruiting:** Polypropylene, high density thermotolerant polyethylene bags, usually fitted with a microporous filter patch, or stuffed with a cotton plug. Bottle fruitings are impractical. Tray fruitings *a la* Button Mushroom culture have been employed with some success in Europe. However, the advantage of bag culture is that contaminants can be isolated, limiting cross-contamination of adjoining substrates.

**Yield Potentials:** 1.5 to 3 lbs. of fresh mushrooms from 6 lbs. of sawdust/chip/bran. Biological efficiency rating of 100-200% using the methods described herein.

**Harvest Hints:** Humidity should be constantly fluctuated during fruitbody development and then lowered to 60% rH for 6-12 hours before the crop is harvested. This causes the cap's leathery, outer skin to toughen, substantially extending shelf-life. I prefer to pick the mushrooms when the margins are still inrolled, at a mid-adolescent stage. However, greater yields are realized if the fruitbodies are allowed to enlarge. For best results, the interests of quality vs. yield must be carefully balanced throughout the cropping process by the growing room manager.

Although these mushrooms can withstand a more forceful water spray than Oyster and other



Figure 249. The "Donko" form of Shiitake can be induced by fluctuating humidity during primordia formation, especially during cool, dry conditions.



Figure 250. Occasionally, a 1 lb. mushroom can be harvested from a 4 lb. block of sterilized, supplemented sawdust.

mushrooms, Shiitake gills readily bruise brownish, reducing quality. (Outdoor grown Shiitake commonly has brown spots caused from insects. These damaged zones later become sites for bacterial blotch.) Mushrooms should be trimmed flush from the surface of the blocks with a sharp knife so no stem butts remain. Dead stems are sites for mold and attract insects. Thumbs should be wrapped with tape, or protected in some manner, as the pressure needed to cut through Shiitake stems is substantially greater than that of most fleshy mushrooms.

**Form of Product Sold to Market:** Dried mushrooms, powdered, fresh mushrooms, and extracts. In Japan Shiitake wine, Shiitake cookies, and even Shiitake candies are marketed.

**Nutritional Content:** Protein 13-18%; niacin (mg./100 g): 55; thiamin (mg./100 g): 7.8; riboflavin (mg./100 g): 5.0. Ash: 3.5-6.5%. Fiber: 6-15%. Fat: 2-5%.

**Medicinal Properties:** Lentinan, a water soluble polysaccharide ( $\beta$ -1,3 glucan with  $\beta$ -1,6 &  $\beta$ -1,3 glucopyranoside branchings) extracted from the mushrooms, is approved as an anti-cancer drug in Japan. The Japanese researcher Chihara was one of the first to publish on the anti-cancer properties of Shiitake, stating that lentinan "was found to almost completely regress the solid type tumors of sarcoma-180 and several kinds of tumors including methylchloranthrene induced fibrosarcoma in synergic host-tumour system." (Chihara, 1978, p. 809.) The mode of activity appears to be the activation of killer and helper "T" cells.

Another heavy weight polysaccharide, called KS-2, isolated by Fujii et al. (1978) also suppressed

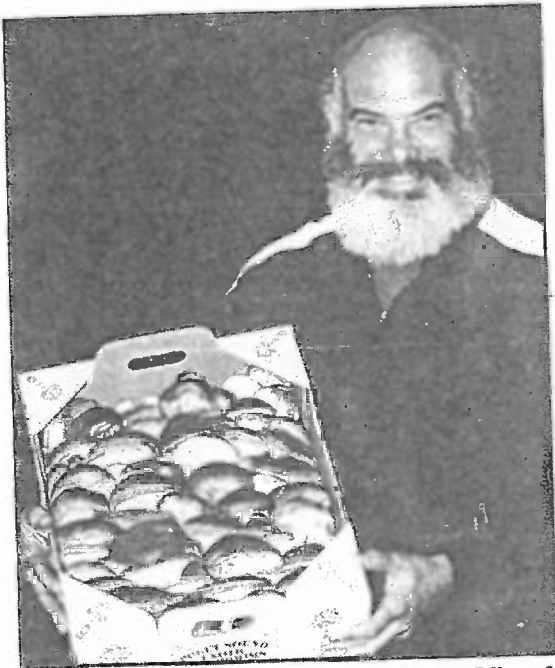

Figure 251. Dr. Andrew Weil happily holds 5 lbs. of freshly picked, organically grown Shiitake.

health stimulating properties. For more information on the medicinal properties of Shiitake, consult Mori et al. (1987), Fujii et al. (1978), Jong (1991), Ladanyi et al. (1993), and Jones (1995).

**Preparation and Cooking:** Shiitake can be enjoyed in a wide variety of dishes. A traditional Japanese soup recipe calls for slicing the mushrooms and placing them in a pre-heated chicken broth complemented with chopped green onions. The addition of miso (often used as a vegetarian substitute for chicken) enhances the flavor. Shiitake are steeped in this soup broth for a few minutes and served hot. The flavor and fragrance of slightly cooked Shiitake is tart and totally different than the flavor imparted from thorough cooking. Chinese restaurants usually rehydrate Shiitake and simmer them in the broth of stir-fries.

Our family regularly consumes Shiitake. Our favorite and standard method is to sauté mushrooms which have been torn, not cut. By tearing the mushrooms, cells are pulled apart along cell walls, preserving the flavor within. The stems are first cut off and the mushrooms are pulled apart, starting from the cut stem base. Canola (rape seed) oil or similar light oil is added to the Wok or frying pan which is then brought to high heat. Once hot, the torn mushrooms are added, stirred frequently, and cooked until the majority of water has been evaporated. While the mushrooms are being cooked, a distinct change in fragrance occurs, becoming more meat-like. Chopped onions, sliced walnuts or shaved almonds, and other condiments can be added as desired. This preparation can be used as a base in many dishes. By adding stir-fired Shiitake to steamed rice, fish, pasta, chicken, and vegetables, a culinary dish of extraordinary dimensions is created. Other dishes using Shiitake includes Cruz's Shiitake Quiche, Shiitake Paté, etc. Please refer to the recipes in Chapter 24.

Sarcoma 180 and Ehrlich ascotes carcinoma in mice via oral introduction. Other protein bound fractions have shown differing degrees of anti-tumor activity. Clearly, there are a number of anti-tumor compounds in Shiitake besides the well known lentinan. To what degree these compounds can help the human immune system through the simple ingestion of cooked mushrooms is not clear.

Studies in the United States have failed to show that extracts of Shiitake are effective against HIV in vitro. (Some Japanese studies have shown effectiveness against HIV; others have not.) Shiitake has also shown promise in lowering blood pressure and cholesterol (Kabir & Yamaguchi, 1987; Jong et al. 1991). The cholesterol lowering compound was identified as eritadenin, an adenine derivative. In the past twenty years, nearly a hundred research papers have been published on the chemical constituents of Shiitake and their



When I was a impoverished, near-starving student living in a remote, unheated 'A' frame house in the boondocks, Jeff Chilton generously delivered flats of fresh Shiitake which I eagerly consumed, cooked and raw. (Since I was so hungry, I didn't care.) To this day Shiitake is the only mushroom I enjoy without the benefit of cooking, fully aware that their potential nutritional contribution is largely untapped.

**Comments:** By comparing Shiitake to Oyster (*P. ostreatus*) mushrooms, several notable similarities and differences in their growth requirements are unveiled. Shiitake can not be grown on the wide range of substrates that the highly adaptive Oyster mushrooms can exploit. Both are phototropic, with Shiitake primordia most stimulated by light exposure of 100-200 lux of green to ultra-violet at 370-420 nanometers (Ishikawa, 1967) while Oyster mushrooms maximally produce mushrooms at 2000 lux at 440-495 nanometers (Eger et al., 1974). I find that although Shiitake primordia are stimulated into formation at this low light level, the development of the fruitbody is retarded unless light levels are increased. Since primordia formation can span a week, I prefer to give the blocks the higher exposure of light initially rather than risking malformation later on. Furthermore, Shiitake produces fairly normal looking mushrooms under high carbon dioxide conditions (> 10,000 ppm) while Oyster mushrooms deform with exaggerated stems and under-developed caps. Other notable distinctions are that Shiitake have a thicker cap, a distinct cap cuticle, a lower spore load, and a markedly longer shelf than the Oyster mushroom.

The cultivation of Shiitake on sterilized, supplemented sawdust calls for a set of techniques very different than for most other mushrooms. (The formula for production is described on page 162.) Shiitake strains are abundant, most will produce, but a few are remarkably more aggressive than others. Exceptionally aggressive strains of Shiitake tend to be warm weather races, tolerant of temperatures up to 90° F. (32° C.). *By employing a super-aggressive strain of Shiitake, propagating the mycelium according to the procedure outlined above, inoculating at a high rate, and using as the base medium a rapidly decomposing hardwood (red alder- *Alnus rubra*) has allowed me to accelerate the Shiitake life cycle far faster than any which has been published to date.* If the supplemented bags of sawdust are agitated 7-10 days after inoculation, primordia formation is triggered soon thereafter. This method causes fruitbody formation in as short as 14 days from inoculation.\*

\* However, agitation of partially sterilized bags often results in a contamination bloom. These same bags would otherwise be completely colonized by the mushroom mycelium if left undisturbed. With sufficiently high spawning rates (10-20% wet weight spawn/wet weight substrate) secondary shaking post inoculation is unnecessary.



Figure 252. A Shiitake wine marketed in Japan.

Early formation of Shiitake has disadvantages. If the network of mycelium is insufficiently formed, lacking both density and tenacity, high quality mushrooms can not be supported. If allowed two weeks of colonization, top grade Shiitake is produced.

When the first crop is picked from the white blocks, they must be carefully cut flush with the outer surface with a sharp knife or chunks of the sawdust substrate will be pulled off. I prefer to hold back the fruitings until 28-35 days after inoculation, allowing less than a dozen mushrooms on the first flush, and then exposing the substrate to the conditions recommended for crop development.

The first flush from white blocks is unique and calls for a strategy totally different than for subsequent flushes. Timing is critical. If one is not attentive, the window of opportunity can pass. During incubation, the outer surface of the myceliated sawdust appears as a smooth flat plane, pressed flush to the surface walls of the polypropylene bags. After waiting 20-25 days until the blocks start "buckling"—an irregular, blister-like surface topography forms.\* These formations are the precursors to primordia. (See Figure 240). Several days after this surface topography forms, temperatures are dropped and small brown spots form at the peaks of the blisters. Often appressing against the interior plastic walls, the primordia can form overnight, measuring 1-3 mm. in diameter. Should more than a dozen mushrooms form, or if develop underneath the plastic, the crop quality greatly suffers. The cultivator must assess the maturity of the primordia population and expose the sensitive mycelium to the air precisely at the right time by stripping the plastic bags from the blocks.

The mycelium is suddenly thrust into the highly aerobic environment of the growing room. Massive evaporation begins from the newly exposed aerial, fluffy white mycelium. For this first flush, which forms topically on the outer surface of the sawdust block, the humidity must be maintained at 100% under fog-like conditions until the desired number of primordia form. At this stage, the Shiitake blocks are snow-white in color and dotted with several brown headed primordia. (See Figure 241). The sudden shift from the CO<sub>2</sub> rich environment within the bag to the highly aerobic environment of the growing room signals the block to bear fruit.

Since these events occur rapidly and the window of opportunity is so narrow, all the skills of the cultivator come into play. Allowing too many primordia to form is a real problem. The more mushrooms that are set, the smaller they will be, increasing the labor at harvest. The fewer mushrooms set, generally the larger they will become. Despite the number of mushrooms that form, the yield remains constant. The first flush from a moist 6 lb. alder sawdust/chip/bran is usually 3/4 to 1 lb. of mushrooms per block.

Once six to a dozen mushrooms form, relative humidity is lowered, and air turbulence is increased to affect greater evaporation. The aerial mycelium collapses, or in mushroom lingo "pans". This flattened mycelium becomes the thickened coat of dead cells, eventually giving rise to the brown skin so characteristic of the remainder of the block's lifespan. (See Figures 246-247).

After the first flush, the fruiting blocks must dry out. The humidity in the growing room is lowered to 30-50% and maintained around 70° F.(21° C.).\*\* After 7-10 days of dormancy, the now browning blocks weigh only 3-4 lbs. of their original weight. The blocks are submerged in water (non-chlori-

---

\* Some cultivators call this "blistering" or "popcorning".

\*\* This fruiting strategy is specific to warm weather strains of Shiitake.

---

nated) for 24-48 hours. (If the water temperature is 45-55° F. (7-13° C.), 48 hours is recommended. If the water temperature is above 60° F. (15-16° C.) then the blocks should not be submerged for more than 24 hours.) At our farm, the blocks are so buoyant as to necessitate extraordinary efforts to keep them submerged. When the number of blocks exceed 500, the process of handling becomes too labor-intensive. Some large scale cultivators use winch driven trolley cars on tracks that drive into the depths of soaking ponds, only to be ferried out the next day. These trolley cars then become the growing racks during the fruiting cycle.

When the blocks are removed from the soak tank, they should be placed directly back into the growing room onto open-wire shelves. During transport, a forceful spray of water removes any extraneous debris, *and* cleans the outer surfaces. If the humidity is raised to 100% at this point in time, disaster soon results. Green molds (*Trichoderma* species) flourish. The constant, and at times, drastic fluctuations in humidity improve crop quality but discourage contamination. When Shiitake growers visit me, the most frequent remark I hear is that green molds are totally absent from the thousand or more blocks in my growing rooms. The absence of green molds is largely a function of how the growing rooms are operated on a daily basis, and minimally influenced by air filtration. The key is to encourage Shiitake growth and discourage competitors by fluctuating humidity several times per day from 70-100%. The rapid evaporation off the surfaces of the blocks retards green mold contamination and benefits mushroom development.

At least once, preferably twice a day, the blocks are washed with a moderately forceful spray of water. (Humidifiers are turned off.) Once the crop is watered, the floor is cleaned by hosing all dirt and debris into the central gutter where it is collected and removed. After this regimen, the room feels "*fresh*". Three days from soaking, white, star-shaped fissures break through the outer, brown surface of the Shiitake block. (See Figure 246). The blocks are wafted with water every 8-12 hours. Since the humidifiers are set at 70-75%, they infrequently come on compared to the initiation strategy called for by Oyster mushrooms.

One week after soaking, the crop cycle begins with the picking of the first mushrooms. Daily watering schedules are dictated by the crop's appearance. At maturity, the moisture content of the mushrooms must be lowered before picking, a technique which will greatly extend shelf life. After the harvest is completed, the blocks are dried out for 7-10 days, after which the re-soaking process begins anew.

This cycle can be repeated several more times. After five flushes, with an accumulated yield of 2-3 lbs. of fresh mushrooms per 6-7 lbs. of sawdust/chip/bran block, the Shiitake mycelium can produce, at most, rapidly maturing miniature mushrooms—few and far between. This is a sure sign that maximum yields have been achieved. Another way of determining whether the block is incapable of producing more mushrooms is to drop the block from waist level to a cement floor. A Shiitake block with good yield potential will strike the surface and not break apart. An expired block will burst upon impact: a direct measure of mycelial fortitude. As the mycelium loses vitality, the tenacity of the mycelial mat is also lost. At completion, the blocks are 1/2 to 1/3 of their original size and are often blackish brown in color. The "spent" blocks can now be recycled by pulverizing them back into a sawdust-like form. The expired Shiitake substrate is then re-sterilized for the sequential cultivation of Oyster, Maitake, Zhu Ling or Reishi mushrooms. See Chapter 27 for more information.

Many supplements can be used to enhance Shiitake production from sterilized sawdust. Tan and Chang (1989) examined the effect of 17 formulations on yield and found that a formula (dry weight) consisting of 71% sawdust, 18% used tea leaves, 7% wheat bran, and 1.4 % calcium carbonate gave the highest yields. When calcium sulfate was substituted for calcium carbonate, no effect on yield was seen. In their opinion, spent tea leaves proved to be an excellent supplement for enhancing yields. Notably, only two strains of Shiitake were used, with only four replicates of each formula for the data trials. Another study by Morales et al. (1991) found that the addition of cotton waste to a sawdust/bran (12.5%) formula significantly improved yields of Shiitake.

These examples can be used as guidelines for Shiitake cultivators who will, inevitably, develop precise formulas and strategies that maximize yields according to their unique circumstances. My method consistently gives first flushes of Shiitake in 25-35 days, with subsequent flushes 10-14 days apart. My final flushes end two months after the first begin. For most other Shiitake growers on sterilized sawdust, their first flushes are just beginning after three months of incubation. Our speed of production sets a new standard for the Shiitake industry. The "secret" of my method is the culmination of a combination of factors: the use of an aggressive strain sustained on a unique agar formula; a high spawning rate; a rapidly decomposing hardwood (alder); water rich in minerals; and the sensitive care of a good cultivator. This technology is transferable and can be taught to anyone.

---

---

## The Nameko Mushroom of the Genus *Pholiota*

---

The Genus *Pholiota* is not known for its abundance of deliciously edible species. Many species are characterized by a glutinous, slimy veil, which coats the surface of the cap making the mushrooms quite unappealing. However, the Japanese have discovered that one species in particular, *Pholiota nameko*, is a superior gourmet mushroom.

*Pholiota nameko* (T. Ito) S. Ito et Imai in Imai

---

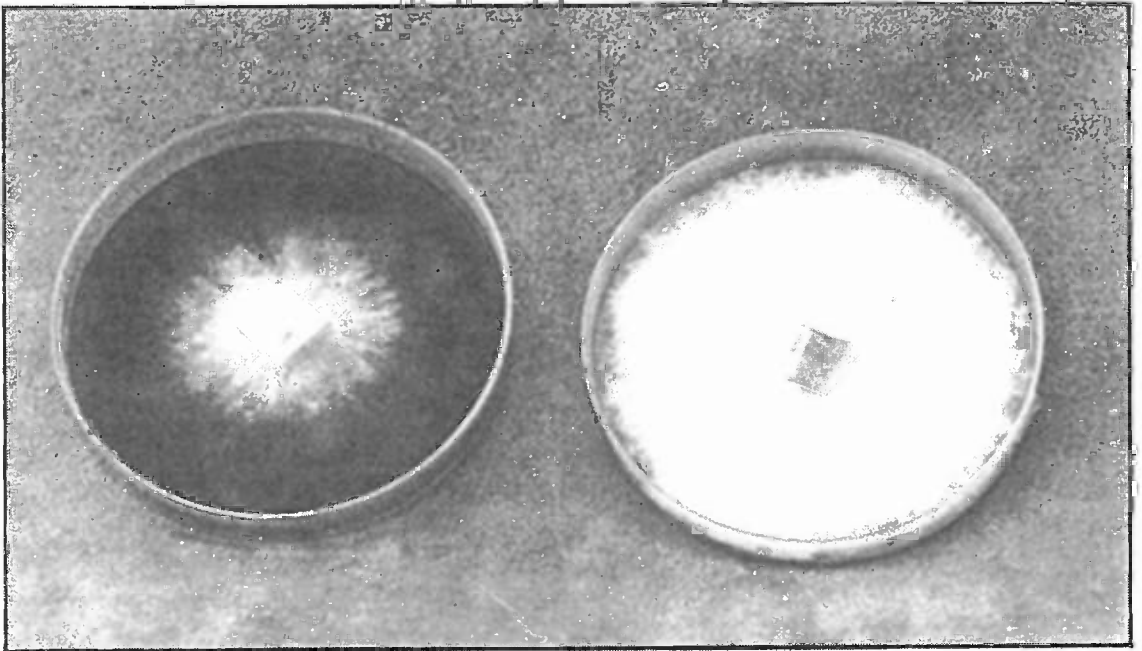

Figure 253. *P. nameko* mycelia 5 and 10 days after inoculation onto MEA media.

**Introduction:** *Pholiota nameko* is one of the most popular cultivated mushrooms in Japan, closely ranking behind Shiitake and Enokitake. This mushroom has an excellent, flavor and texture. *P. nameko* would be well received by North Americans and Europeans if it were not for the thick, translucent, glutinous slime covering the cap. (This mucilaginous coat is common with many species of *Pholiota*.) Although unappealing to most, this slime soon disappears upon cooking and is undetectable when the mushrooms are served. My 12 year old son and I have engaged in more than one culinary battle to get the last tasty morsels of this mushroom! This mushroom is a superb edible which can be grown easily on sterilized, supplemented sawdust, and/or logs.

---

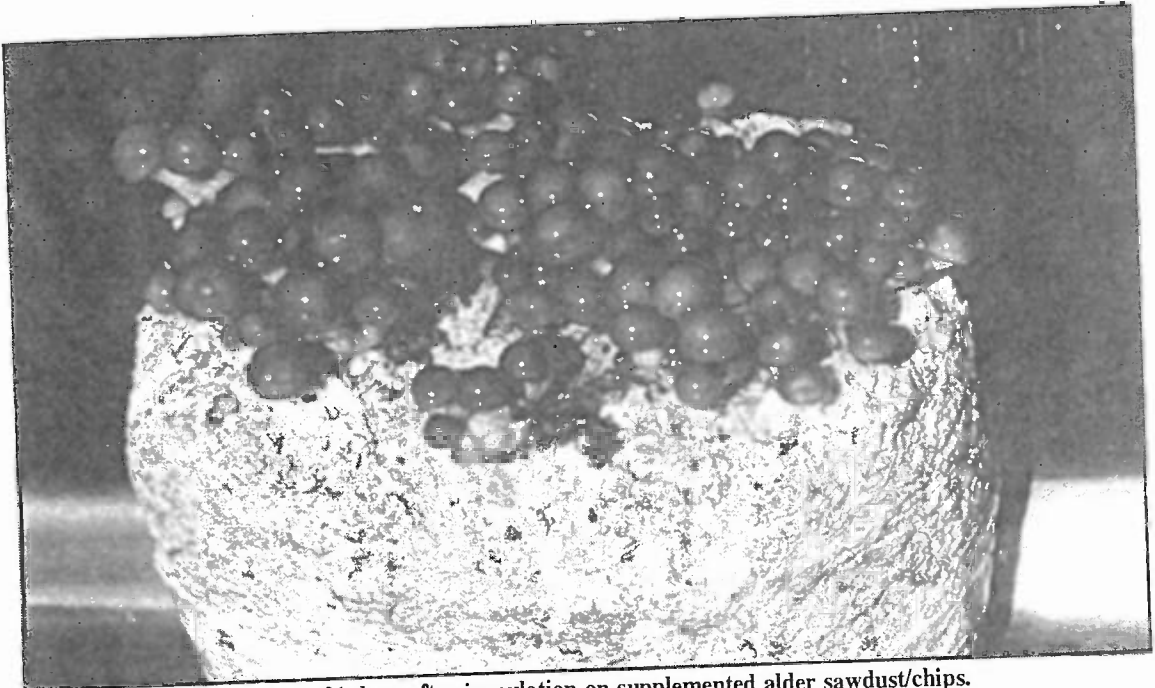

Figure 254. Primordia form 21 days after inoculation on supplemented alder sawdust/chips.

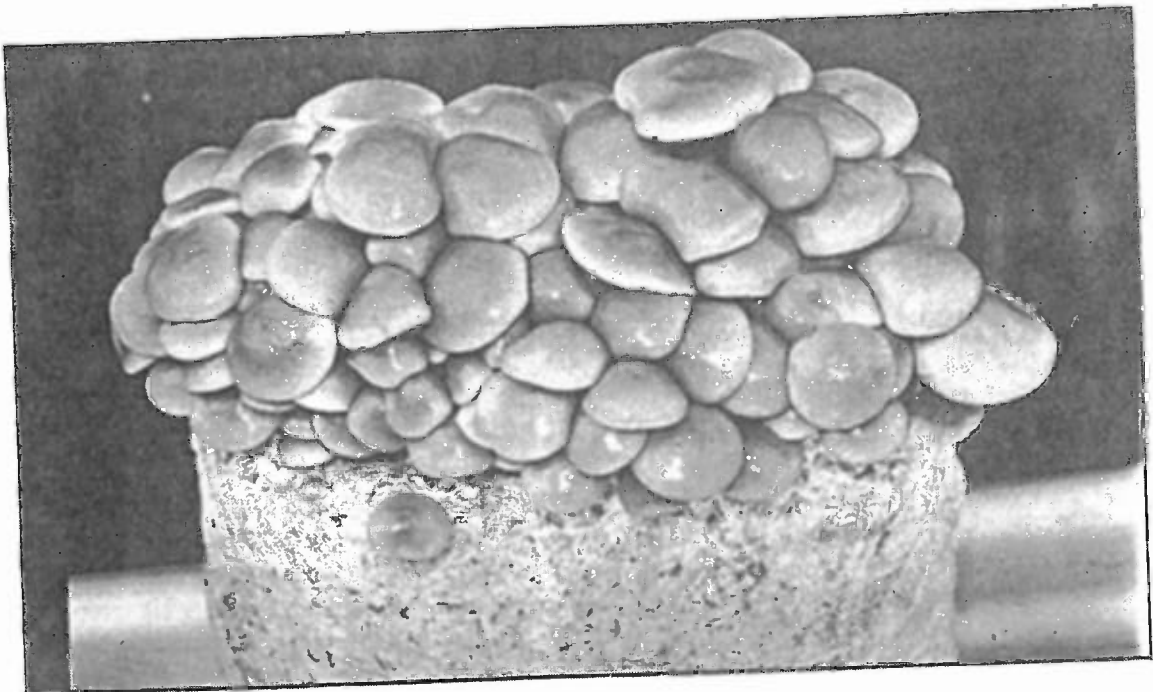

Figure 255. The same block 72 hours later.

## Growth Parameters

### Spawn Run:

Incubation Temperature: 75-85°F. (24-29° C.)

Relative Humidity: 95-100%

Duration: 2 weeks

CO<sub>2</sub>: >5000 ppm

Fresh Air Exchanges: 0-1

Light Requirements: n/a

### Primordia Formation:

Initiation Temperature: 50-60° F. (10-15.6° C.)

Relative Humidity: 98-100%

Duration: 7-10 days

CO<sub>2</sub>: 500-1000 ppm

Fresh Air Exchanges: 4-8 per hour

Light Requirements: 500-1000 lux.

### Fruitbody Development:

Temperature: 55-65° F. (13-18° C.)

Relative Humidity: 90-95%

Duration: 5-8 days

CO<sub>2</sub>: 800-1200 ppm

Fresh Air Exchanges: 4-8 per hour

Light Requirements: 500-1000 lux.

### Cropping Cycle:

Two crops in 60 days, 10-14 days apart.

---

**Common Names:** Nameko or Namerako (Japanese for "Slimy Mushroom")

Slime Pholiota

Viscid Mushroom

**Taxonomic Synonyms & Considerations:** *P. nameko* is synonymous with *Pholiota glutinosa* Kawamura. Formerly placed in *Collybia* and *Kuehneromyces*, this mushroom is uniquely recognizable for its smooth cap and glutinous veil covering the mushroom. The type specimen of *Collybia nameko* T.Ito was found, upon re-examination to be none other than *Flammulina velutipes*, although its original description by Ito obviously conformed to the mushroom we now call Nameko. Hence, the latin name is burdened by interpretations by several mycologists. The reader should note, that "Nameko" is a common name, once applied to many Japanese mushrooms with a viscid or glutinous cap. The common name has since become restricted to one species, i.e. *Pholiota nameko*.

**Description:** Cap 3-8 cm., hemispheric to convex, and eventually plane. Surface covered with an

---

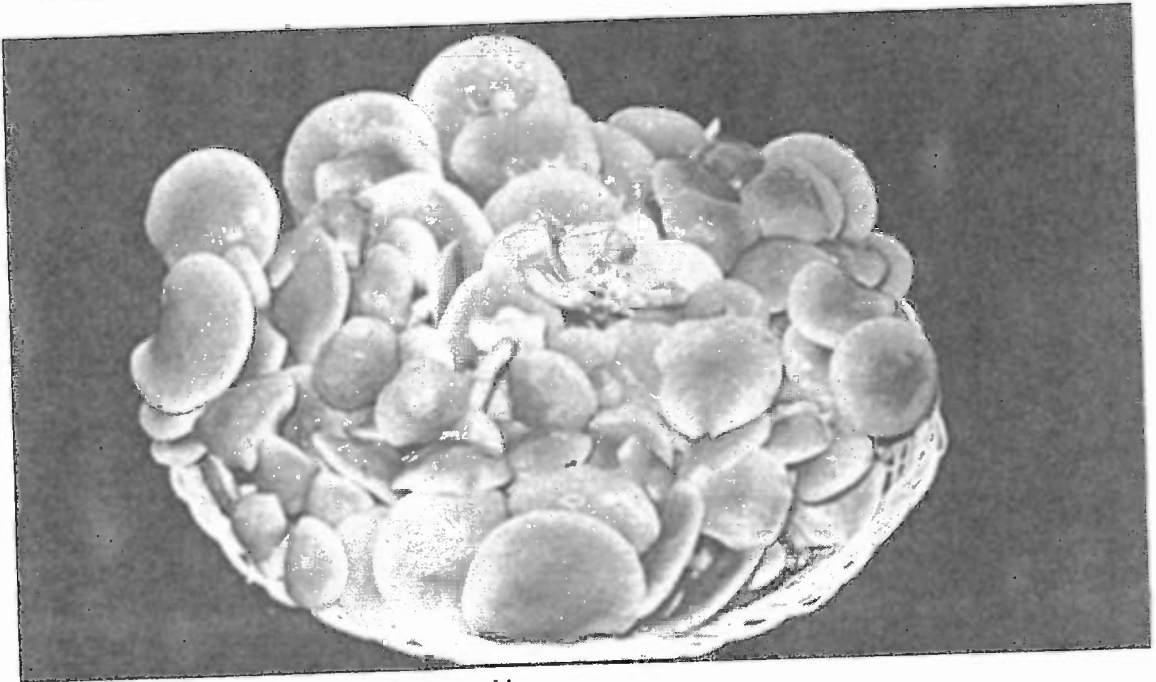

Figure 256. The harvested crop ready for cooking.

orangish, glutinous slime, thickly encapsulating the mushroom primordia, thinning as the mushrooms mature. The slime quickly collapses, leaving a viscid cap. Cap surface smooth. Gills white to yellow, becoming brown with maturity. Partial veil glutinous/membranous, yellowish, adhering to the upper regions of the stem or along the inside peripheral margin. Stem 5-8 cm. long, equal, covered with fibrils and swelled near the base.

**Distribution:** Common in the cool, temperate highlands of China, Taiwan, and throughout the islands of northern Japan. Not known from Europe or North America.

**Natural Habitat:** On broad-leaf hardwood stumps and logs in the temperate forests of Asia, especially deciduous oaks and beech (*Fagus crenata*).

**Microscopic Features:** Spores cinnamon brown, ellipsoid, small,  $4-7 \mu \times 2.5-3.0 \mu$ , smooth, lacking a distinct germ pore. Pleurocystidia absent. Clamp connections present. This mushroom has a conidial stage which allows the formation of spores directly from the mycelium. Nameko is unique (in contrast to the other species listed in this book) in that a single spore can project a homokaryotic mycelium, and generate mushrooms with homokaryotic spores.

**Available Strains:** Strains are available from most Asian culture libraries.

**Mycelial Characteristics:** Whitish, longitudinally radial, becoming light orangish or tawny from the center as the mycelium ages. On sterilized grain the mycelium is densely cottony white and becomes speckled with yellowish to orangish zones at maturity.

**Fragrance Signature:** Musty, farinaceous, not pleasant.



**Natural Method of Outdoor Cultivation:** On logs of broad-leaf hardwoods, especially beech, poplar and assorted deciduous oaks, *a la* the method for Shiitake. Because of the high moisture requirement for this mushroom, partially burying the logs in a high peat moss soil base is recommended.

**Recommended Courses for Expansion of Mycelial Mass to Achieve Fruiting:** Spawn is quickly generated with liquid inoculation of grain from petri dish cultures. The grain spawn can be exponentially expanded two generations using standard grain-to-grain inoculations. Intermediate sawdust spawn can then be produced from the grain spawn for final inoculation into supplemented hardwood sawdust. For many cultivators, going from grain spawn to supplemented sawdust is an easier, and more direct approach.

**Suggested Agar Culture Media:** MEA, MYA, PDYA and DFA.

**1st, 2nd and 3rd Generation Spawn Media:** Grain spawn throughout.

**Substrates for Fruiting:** The supplemented sawdust formula described in Chapter XVII is recommended. Arita (1969) recommends that no more than 10% rice bran be used as a supplement for oak hardwood formulations. However, I have found that 20% rice bran supports a more massive first flush and second flush when using *Alnus rubra* (red alder). Arita also found that the addition of 15% rice bran was the optimum if using conifer sawdust (*Pinus densiflora*—Asian Pine and *Cryptomeria japonica*—Japanese Cedar) as the base substrate.) This is one of the few gourmet mushrooms that will give rise to substantial fruitings on conifer wood.

**Recommended Containers for Fruiting:** Autoclavable bottles and polypropylene bags.

**Yield Potentials:** The fruitings pictured in this book yielded, on the first flush, an average of slightly more than 1 lb. of mushrooms from 5 lb. blocks of hardwood sawdust supplemented with rice bran.

**Form of Product Sold to Market:** Primarily fresh mushrooms are sold. An interesting, tasteful, if not elegant mushroom, *Pholiota nameko* is a mushroom well worth cultivating. Whether or not its marketing in North America will be successful is another question. *P. nameko* is very popular in Japan. Its flavor is so distinct and appealing as to win over the squeamishly skeptical.

**Nutritional Content:** Crude protein (N x 4.38): 20.8%; fat: 4.2%; carbohydrate: 66.7%; ash: 8.3%; and fiber: 6.3%. Vitamins (in milligrams per 100 grams dry weight): thiamine: 18.8; riboflavin 14.6; niacin 72.9. Minerals (in milligrams per 100 grams dry weight): calcium: 42; potassium: 2083; iron: 22.9; sodium: 63.

**Medicinal Properties:** According to Ying (1987), water and sodium hydroxide extracts of this mushroom are 60% & 90% effective, respectively, against Sarcoma 180 implanted in white mice. Further, resistance to infection by *Staphylococcus* bacteria is substantially improved. No parallel studies by Western researchers are known to this author. The references making these medical claims are in Chinese.

**Flavor, Preparation & Cooking:** A very slimy mushroom—a feature that has caused less consternation in Asia than in North America. Nameko is easily diced into miniature cubes and can be used imaginatively in a wide variety of menus, from stir fries to miso soups. Although pleasantly satisfying when lightly cooked, I prefer the strong flavor that thorough cooking evokes. Once the glutinous slime is cooked away, the mushroom becomes quite appetizing, having a crunchy and nutty/mushroomy flavor.

In Japan one can often find fresh Nameko for sale while in the United States only canned mushrooms have been available. Every fall, select Japanese restaurants in the United States feature this mushroom in a traditional autumn soup which is clear, subtly seasoned with tiny bits of coriander leaf and other herbs.

**Comments:** This mushroom is more sensitive to moisture and carbon dioxide levels than most. For indoor cultivation, a precise initiation strategy is called for. I prefer not to use a casing layer as it promotes contamination, makes the cleaning of mushrooms tedious, and is unnecessary with good environmental controls in the growing room.

Should a casing layer not be applied, the block of supplemented sawdust must be exposed to a "condensing-fog" environment during the primordia formation period. If the aerial mycelium suddenly dehydrates, and dies back, surface primordia will be prevented and no crops will form. In this event, the cultivator must either roughen the surface of the block and/or apply a moist casing layer, two second-choice alternatives.

To initiate mushroom formation, temperatures are lowered to the 50-60° F. (10-15° C.) range, carbon dioxide levels are lowered, relative humidity is increased to 98-100 % rH, light levels are increased to >500 lux, and the surface mycelium is frequently misted with a fine spray of water. Approximately a week after initiating, orange streaks of slime form across the exposed surface of the mycelium. It is essential that the cultivator encourages the formation of this marmalade-looking goop. Soon thereafter, populations of primordia form and emerge within this overlaying, glutinous mass. So elastic is this material that it can be stretched more than 6 inches with each pull. This glutinous layer acts as a moisture bank promoting mushroom formation and development. Should this layer collapse due to dehydration, the primordia are at risk of aborting.

Rather than removing the entire polypropylene bag, I recommend that most cultivators cut off the top portion of the incubation bag, leaving 3-4 inch side walls of plastic surrounding the exposed, upper surface of the sensitive mushroom mycelium. These plastic walls will help collect moisture, enhancing primordia formation. If done properly, the mushroom stems will elongate to exactly the height of these walls, facilitating harvest.

Using this casing-less approach, the second flush will be poor unless the surface is roughened to expose viable mycelium. A paddle with extruding nails or a wire brush serves this purpose well. Once the surface layer is torn apart, humidity is again raised to achieve the condensing-fog atmosphere. Soon thereafter (4-7 days), the mycelium becomes aerial, fuzzy, regenerates the orange slime layer, giving rise to another break of mushrooms. To achieve a third flush, I recommend turning the block upside down, roughening its surface, and following a similar strategy to that described above. Fourth and fifth flushes are usually not substantial. However, I have put Nameko blocks into my "mushroom graveyard", letting nature prevail, and have been pleasantly surprised at getting more mushrooms. Be forewarned. For a slug, there can be no better feast than this slimy *Pholiota*!

The advantages of not using a casing layer are: less work; less risk of green mold (*Trichoderma*) contamination; and the harvested mushrooms are free of debris. Because of the glutinous nature of the *P. nameko* fruitbodies, casing debris readily adheres to, and is difficult to remove from the harvested mushrooms and your fingers.

---

## The Oyster Mushrooms of the Genus *Pleurotus*

---

Oyster mushrooms are by far the easiest and least expensive to grow. For small cultivators with limited budgets, Oyster mushrooms are the clear choice for gaining entry into the gourmet mushroom industry. Few other mushrooms demonstrate such adaptability, aggressiveness, and productivity as these species of *Pleurotus*. Preeminent wood decomposers, *Pleurotus* species grow on a wider array of forest and agricultural wastes than species from any other group. They thrive on most all hardwoods, on wood by-products (sawdust, paper, pulp sludge), all the cereal straws, corn and corn cobs, on sugar cane bagasse, coffee residues (coffee grounds, hulls, stalks, & leaves), banana fronds, cottonseed hulls, agave waste, soy pulp and on other materials too numerous to mention and difficult to imagine possible. More than any other group of mushrooms, *Pleurotus* species can best serve to reduce hunger in developing nations, and to revitalize rural economies. To this end, world-wide Oyster mushroom production has surged in recent years, from 169,000 metric tons in 1987 to 909,000 in 1990.

Most extraordinary about Oyster mushrooms is their conversion of substrate mass into mushrooms. Biological efficiencies often exceed 100%, some of the greatest, if not the greatest, in the world of cultivated mushrooms. In the course of decomposing dry straw, nearly 50% of the mass is liberated as gaseous carbon dioxide, 20% is lost as residual water, 20% remains as "spent" compost, and 10% is converted into dry mushrooms. (See Figure 39 and Chapter 7 for an explanation of Biological Efficiency.) This yield can be also expressed as a 25% conversion of the wet mass of the substrate into fresh mushrooms. This formula is greatly affected by the stage at which the mushrooms are harvested.

On a dry weight basis, Oyster mushrooms have substantial protein, ranging from 15-35% and contain significant quantities of free amino acids. They are replete with assorted vitamins such as vitamin C (30-144 mg. per 100 grams) and vitamin B, niacin (109 mg. per 100 grams). The variation in the reported nutritional analysis of Oyster mushrooms is due to several factors. The protein content is affected by the type of substrate and by the spawning media and rate. Finally strains of *Pleurotus* vary in their nutritional composition and yield performances. For more information on the nutritional properties of Oyster mushrooms, refer to the articles by El Kattan (1991), Rai et al. (1988), and Bano & Rajarathnam (1982).

Three notable disadvantages persist in the cultivation of Oyster mushrooms. Foremost is that the mushrooms are quick to spoil, presentable to the market for only a few days. (This supports argument that local producers supply local markets). Secondly, the spore load generated within the growing room can become a potential health hazard to workers. Sporeless strains, which tend to have short gills and are thicker fleshed, prolonging storage, are highly sought after by Oyster growers. (See Figure 282). Thirdly, the grower must wage a constant battle against the intrusion of flies. Oyster mushrooms attract Sciariid and Phorid flies to a far greater degree than any other group of mushrooms described in this book. The flies swirl in frenzied aerial dances around mature Oyster mushrooms, aroused by spore release.

---

New strains of Oyster mushrooms are easy to acquire by cloning wild specimens. Most clones will grow to fruition in culture with deformity of the fruitbody and excessive spore load being the most commonly encountered, negative characteristics. Often times, wild clones of Oyster mushrooms result in frenetically growing mycelium, replete with multiple sectors, and readily produce premature mushrooms on malt sugar agar media.

The color of the Oyster mushrooms span the rainbow: white, blue, gray, brown, golden and pink! Of all these, the high temperature tolerant *Pleurotus pulmonarius* is the easiest to grow. For flavor, the King Oyster, *Pleurotus eryngii*, reigns supreme. The Golden Oyster, *Pleurotus citrinopileatus*, and the Pink Oyster, *Pleurotus djamor* are the most brilliantly colored. The Tree Oyster, *Pleurotus ostreatus*, is the most widespread throughout the hardwood forests of the world, and hosts the most diverse varieties from temperate climates. In sterile culture, the dimorphic *Pleurotus cystidiosus* is by far the most unique.

In growing Oyster mushrooms, several valuable by-products are generated. After the crop cycle is complete, the remaining substrate is rendered into a form which can be used as feed for cattle, chickens and pigs. Using the spent straw as a nutritious food source could help replace the wasteful practice of feeding grain in the dairy and cattle industry. For more information on the applicability of "spent" straw from Oyster mushroom cultivation as fodder, please consult Zadrazil, 1976 & 1977; Streeter et al., 1981; Sharma & Jandlak, 1985; Bano et al., 1986; and Calzada et al., 1987.

Feed is but one use of myceliated straw. In the end, the remaining myceliated substrate mass is an excellent ingredient for building composts and new soils. The waste straw may yield another by-product of economic importance: environmentally safe but potent nematicides. At least five Oyster mushroom species secrete metabolites toxic to nematodes. (Thorn & Barron (1984)). Lastly, the waste straw remains sufficiently nutritious to support the growth of *Stropharia rugoso-annulata*, outdoors. Additional products could include the recapturing of considerable quantities of enzymes secreted in the course of substrate decomposition.

From a taxonomic point of view, the Genus *Pleurotus* has been hard to place. Singer (1986) throws the genus into Polyporaceae family along with *Lentinus*. Others have suggested the genus belongs to the Tricholomataceae. However, the more the Genus *Pleurotus* is studied, the more discrete this group appears. Until DNA studies indicate otherwise, I am following Watling and Gregory (1989) who place the Genus *Pleurotus* into their own family, the Pleurotaceae.

---

## *Pleurotus citrinopileatus* Singer

**Introduction:** Few mushrooms are as spectacular as this one. Its brilliant yellow color astonishes all who first see it. This species forms clusters hosting a high number of individual mushrooms, whose stems often diverge from a single base. Its extreme fragility post harvest limits its distribution to far away markets. Spicy and bitter at first, this mushroom imparts a strong nutty flavor upon thorough cooking. *Pleurotus citrinopileatus* grows quickly through pasteurized straw and sterilized sawdust, and thrives at high temperatures.

**Common Names:** The Golden Oyster Mushroom  
Il' mak (Soviet Far East term for elm mushroom)

### **Taxonomic Synonyms & Considerations:**

*Pleurotus citrinopileatus* is closely allied to *Pleurotus cornucopiae* (Paulet) Roll. and is often considered a variety of it. Moser (1978) and Singer (1986) described *P. cornucopiae* var. *cornucopiae* as having a tawny brown cap whereas *P. citrinopileatus* has an unmistakably brilliant yellow pileus.

Singer (1986) separated *P. citrinopileatus* Singer from *P. cornucopiae* (Paulet ex Fr.) Rolland sensu Kuhn. & Rom. (= *P. macropus* Bagl.) on the basis of the arrangement of the contextual hyphae. According to Singer *P. citrinopileatus* has monomitic hyphae whereas *P. cornucopiae* has dimitic hyphae, a designation that has caused considerable confusion since he used this feature as a delineating, sub-generic distinction.\* Upon more careful examination, Parmatso (1987) found that the context was distinctly dimitic, especially evident in the flesh at the stem base. This observation concurs with Watling & Gregory's (1989) microscopic observations of *P. cornucopiae*.

Hongo (1976) describes the Golden Oyster mushroom as a variety of *P. cornucopiae*, i.e. *Pleurotus cornucopiae* (Paulet ex Fries) Rolland var. *citrinopileatus* Singer. Petersen's (1993) interfertility studies showed a culture of *P. citrinopileatus* from China was indeed sexually compatible with *P. cornucopiae* from Europe. From my own experiences, the golden color of *P. citrinopileatus* can be

\* Singer first collect *P. citrinopileatus* when fleeing German forces during World War II. He traveled east, across Asia, and during his travels found the Golden Oyster mushroom. Dried samples were brought to the United States for study years later. This contradiction in the arrangement of the contextual hyphae may simply be a result of poor specimen quality. Contextual hyphae is more easily compared from tissue originating near the stem base than from the cap. Hence, such confusion is not uncommon when examining old and tattered herbarium specimens.

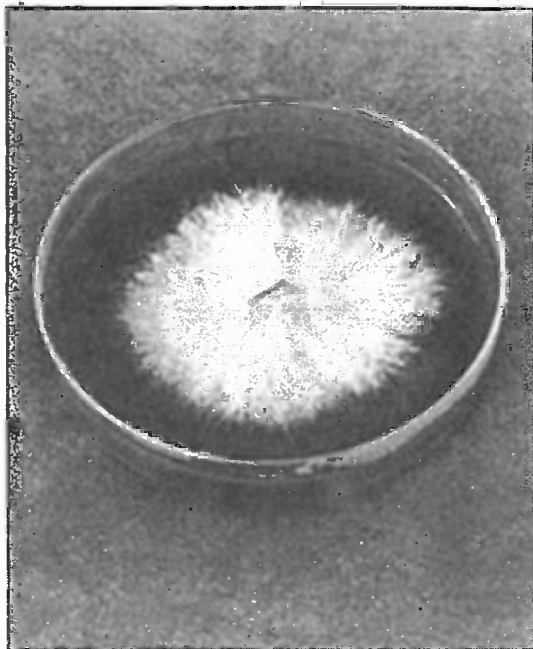

Figure 257. *P. citrinopileatus* mycelium 5 days after inoculation onto malt extract agar medium.

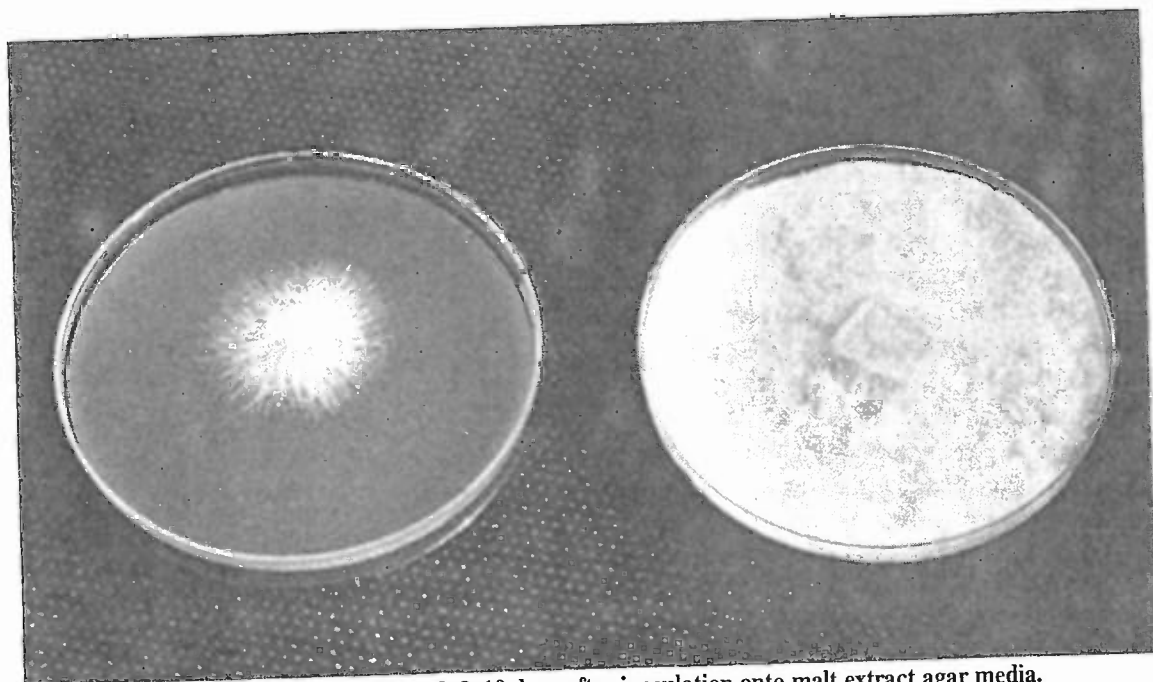

Figure 258. *P. citrinopileatus* mycelium 2 & 10 days after inoculation onto malt extract agar media.

cultured out, resulting in a grayish brown mushroom closely conforming, macroscopically, to *P. cornucopiae* var. *cornucopiae*. \* Geographically, *P. citrinopileatus* is limited to Asia whereas *P. cornucopiae* occurs in Europe. Neither have yet been found growing wild in North America. With the onset of commercial cultivation of these mushrooms adjacent to woodlands in North America, it will be interesting to see if these exotic varieties escape. In this book, I am deferring to the use of *P. citrinopileatus* rather than *P. cornucopiae* var. *citrinopileatus*.

**Description:** Caps golden to bright yellow, 2-5 cm., convex to plane at maturity, often depressed in the center, thin fleshed, with decurrent gills which show through the translucent cap flesh. Stems white, centrally attached to the caps. Usually growing in large clusters arising from a single, joined base. Clusters are often composed of fifty to hundred or more mushrooms. As strains of this species senesce, the yellow cap color is lost, becoming beige, and fewer mushrooms are produced in each primordial cluster.

**Distribution:** Native to the forested, subtropics of China, southern Japan, and adjacent regions.

**Natural Habitat:** A saprophyte of Asian hardwoods, especially oaks, elm, beech and poplars.

**Microscopic Features:** Spores pale pinkish buff, 7.5-9.0 x 3.0-3.5  $\mu$ . Clamp connections present. Hyphal system dimitic.

**Available Strains:** Strains of this mushroom have been difficult to acquire in North America. While travel-

\* Curiously, when the strain loses its golden color through continued propagation, the bitter flavor is also lost.

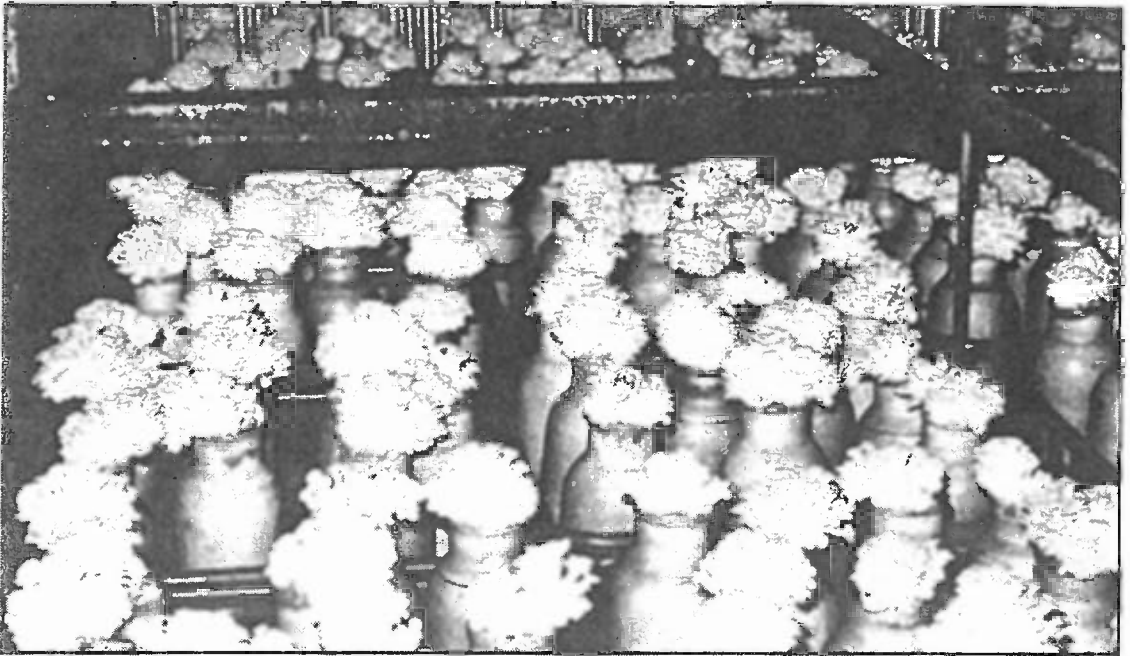

Figure 259. Bottle culture of *P. citrinopileatus* in Hokkaido, Japan.

ing through China in 1983, I made clones of Chinese mushrooms. Using a BIC™ lighter and a small scalpel, I inoculated ten test tube slants without the benefit of any laboratory facility. One of those clones survived the return trip. This is the strain prominently featured here.

**Mycelial Characteristics:** Cottony, whitish mycelium, often with tufts of dense growth, sometimes with yellowish tones, and occasionally run through with underlying rhizomorphic strands.

Primordia are yellow at first, especially from strains kept close to their natural origins. Mycelium dense on grain. Colonization of bulk substrates at first wispy, only becoming dense well after colonization. This mushroom casts a much finer mycelial mat at first than, for instance, *Pleurotus ostreatus* or *P. pulmonarius* on wheat straw.

**Fragrance Signature:** Grain spawn smells astringent, or acrid, nutty, sometimes “fishy”, with a scent that, in time, is distinctly recognizable to this species.

**Natural Method of Cultivation:** This species will grow on logs and stumps, especially of *Ulmus* and *Carpinus* species much like *P. ostreatus*. Hilber (1982) reported that, per cubic meter of elm wood, the yield from one season averaged 17-22 kilograms! Also grown on cottonseed hulls, sugar cane bagasse, straw and sawdust in China. In the United States wheat straw or hardwood sawdust are most frequently employed for substrate composition.

**Recommended Courses for Expansion of Mycelial Mass to Achieve Fruiting:** Grain spawn sown directly into sterilized sawdust or pasteurized substrates. The generation of intermediate sawdust

spawn is not necessary. Straw inoculated with grain spawn has substantially greater yields than straw inoculated with sawdust spawn.

**Suggested Agar Culture Media:** MYA or PDYA.

**1st, 2nd & 3rd Generation Spawn Media:** Rye, wheat, sorghum, milo or millet.

**Substrates for Fruiting:** Pasteurized wheat, cottonseed hulls, chopped corn cobs, and hardwood sawdusts. Alternative substrates being developed commercially are sugar cane bagasse, paper by-products, banana fronds and peanut hulls. Every part of the coffee plant can be recycled growing Oyster mushrooms—from the coffee grounds to the hulls, stalks, limbs and leaves!

**Recommended Containers for Fruiting:** Perforated plastic columns, bags, trays and bottles.

**Yield Potentials:** This species is not as prolific as the more commonly cultivated *P. ostreatus* and *P. pulmonarius* in the conversion of substrate mass to mushrooms. After the second flush, comparatively few mushrooms form. Biological efficiency rating: 25-75% indoors on wheat straw. Yield efficiencies are higher on cottonseed amended substrates.

**Harvest Hints:** Since picking individual mushrooms is tedious and often damages the fragile fruitbodies, cultivators should pursue strategies which encourage clusters hosting large numbers of young mushrooms. Marketing of clustered bouquets is far easier than selling individual mushrooms.

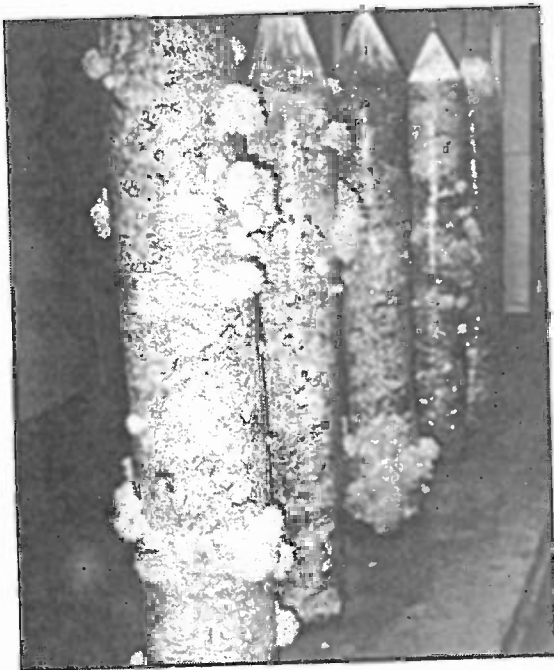

Figure 260. Column culture of *P. citrinopileatus*.

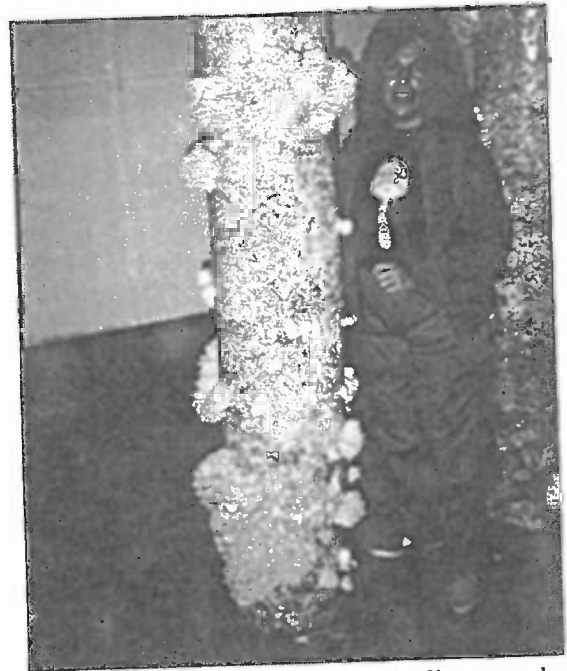

Figure 261. Cruz Stamets beside 14 in. diameter column of the Golden Oyster mushroom fruiting 14 days after inoculation into wheat straw.



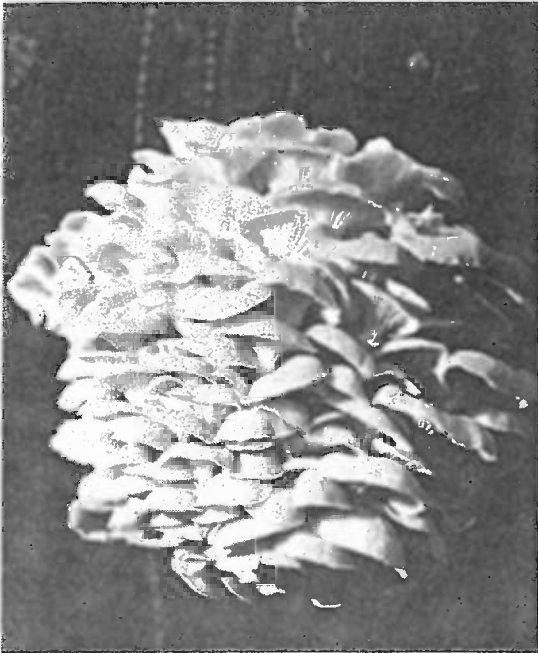

Figure 262. A beautiful clustered bouquet of the *P. citrinopileatus*.

**Form of Product Sold to Market:** Fresh and dried mushrooms. (The golden color fades in drying.) This mushroom is especially popular in Asia.

**Nutritional Content:** Not known to this author. This mushroom is likely to have a similar nutritional profile as *P. ostreatus*.

**Medicinal Properties:** According to Ying (1987) in *Icons of Medicinal Fungi*, *P. citrinopileatus* potentially cures pulmonary emphysema. The supportive references are in Chinese.

**Flavor, Preparation & Cooking:** Mushrooms are better broken into small pieces and stir-fried, at high heat for at least 15-20 minutes. This mushroom is extremely bitter and tangy when lightly cooked, flavor sensations pleasant to few and disdained by most. However,

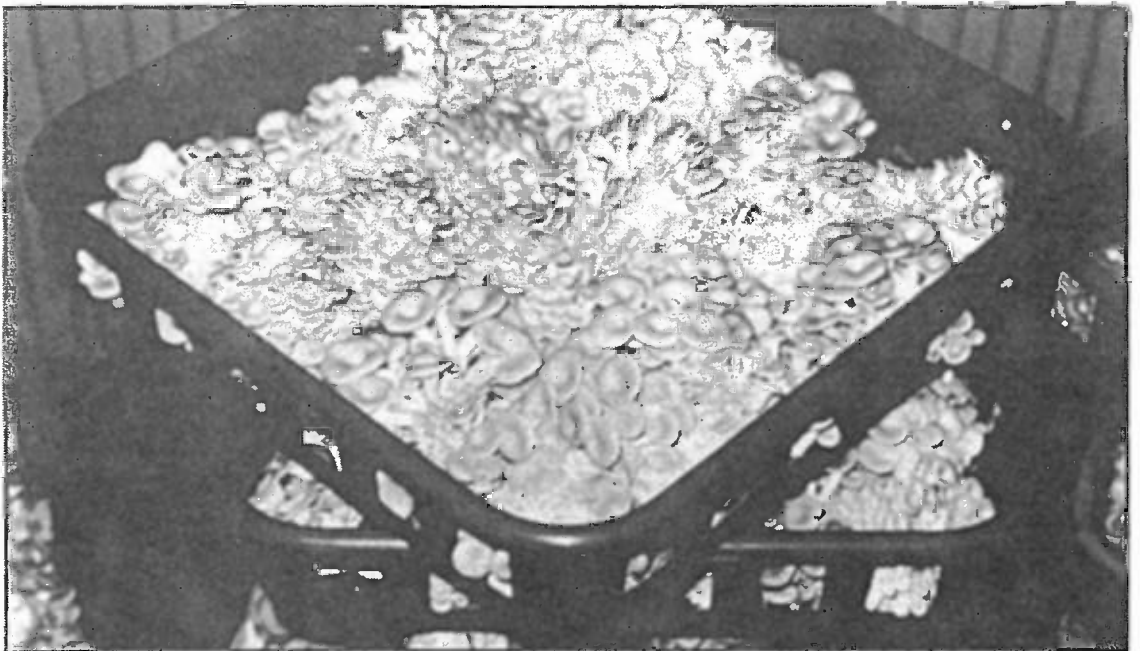

Figure 263. Harvested bouquets of *P. citrinopileatus* ready for retail packaging.

## Growth Parameters

### Spawn Run:

Incubation Temperature: 75-85° F. (24-29° C.)

Relative Humidity: 90 -100%

Duration: 10-14 days.

CO<sub>2</sub>: 5000 - 20,000 ppm.

Fresh Air Exchanges: 1-2 per hour

Light Requirements: n/a

### Primordia Formation:

Initiation Temperature: 70-80° (90°) F. (21-27° (32°)C.)

Relative Humidity: 98-100%

Duration: 3-5 days

CO<sub>2</sub>: < 1000 ppm

Fresh Air Exchanges: 4-8

Light Requirements: 500-1000 lux.

### Fruitbody Development:

Temperature: 70-85° F. (21-29° C.)

Relative Humidity: 90-95%

Duration: 3-5 days

CO<sub>2</sub>: < 1000 ppm

Fresh Air Exchanges: 4-8

Light Requirements: 500-1000 lux.

### Cropping Cycle:

Two crops, 10-14 days apart.

---

when they are crisply cooked, a strong, appealing cashew-like flavor eventually develops. This progression of flavors, primarily affected by the duration of cooking, underscores the Golden Oyster mushroom's versatility as an esculent.

**Comments:** An eye-stopper, the Golden Oyster Mushroom is one of the most spectacular of all gourmet mushrooms. When strains of this mushroom are over-cultured, the golden color is one of the first features to be lost. The brightness of the gold cap color is directly related to the intensity of light in the growing room. A high temperature tolerant mushroom, primordia will not form below 60-65° F. (16-18° C.). Coupled with the brevity of time between spawning and fruiting, and its fondness for cottonseed hulls, this mushroom is better suited for cultivation in warmer climates of Asia, the southern United States or Mexico, or during the summer months in temperate regions. Its penchant for forming clusters, which I call golden gourmet bouquets, makes harvesting easy and prevents damage to individual mushrooms.

*P. citrinopileatus* does, however, have some limitations which should be carefully considered be-

---



Figure 264. Fungi Perfecti's Golden Oyster Mushroom Kit.

fore embarking on large-scale commercial cultivation. *Pleurotus citrinopileatus* is extremely fragile, easily breaking if mishandled, especially along the thin cap margin, complicating long distance shipping. The fruitbodies quickly lose their bright yellow luster subsequent to harvest. Higher spawning rates (15-20% fresh spawn/dry substrate) are required to assure the full colonization of most pasteurized materials. And, cropping yields are not nearly as good compared to other *Pleurotus* species. However, its rarity and broad range of flavors, make this species uniquely marketable and pleasurable to grow.



*Pleurotus cystidiosus* O.K. Miller

**Introduction:** This mushroom and its close allies have a unique biology and are by far the most interesting of all the Oyster mushrooms. The asexual stage appears to be a “contaminant” to most cultivators. In fact, species in this group are dimorphic—having a sexual and asexual life cycle. A nearly identical species, *Pleurotus abalonus*, is commercially cultivated in Asia, particularly Taiwan and Thailand. *Pleurotus cystidiosus* was first described by Dr. Orson K. Miller in 1969 from a maple in Indiana.

**Common Names:** The Abalone Mushroom  
The Maple Oyster Mushroom  
Miller’s Oyster Mushroom

**Taxonomic Synonyms and Considerations:** *Pleurotus cystidiosus* shares greatest similarity, from a cultural viewpoint, *P. abalonus* Han, Chen & Cheng and *P. smithii* Guzman, and may well be conspecific with these two taxa. Hilber (1989) believes that a combination of features can delimit *P. abalonus* from *P. cystidiosus*.

*P. abalonus* has a cap which is darker in color, white pileocystidia and brown cheilocystidia whereas *P. cystidiosus* has a cap lighter in color, translucent brownish pileocystidia and thin-walled hyaline cheilocystidia. Furthermore, Hilber states these taxa can be further delineated by spore size. Soon-to-be-published interfertility and DNA studies should clarify the question of synonymy between *P. cystidiosus*, *P. abalonus* & *P. smithii*.

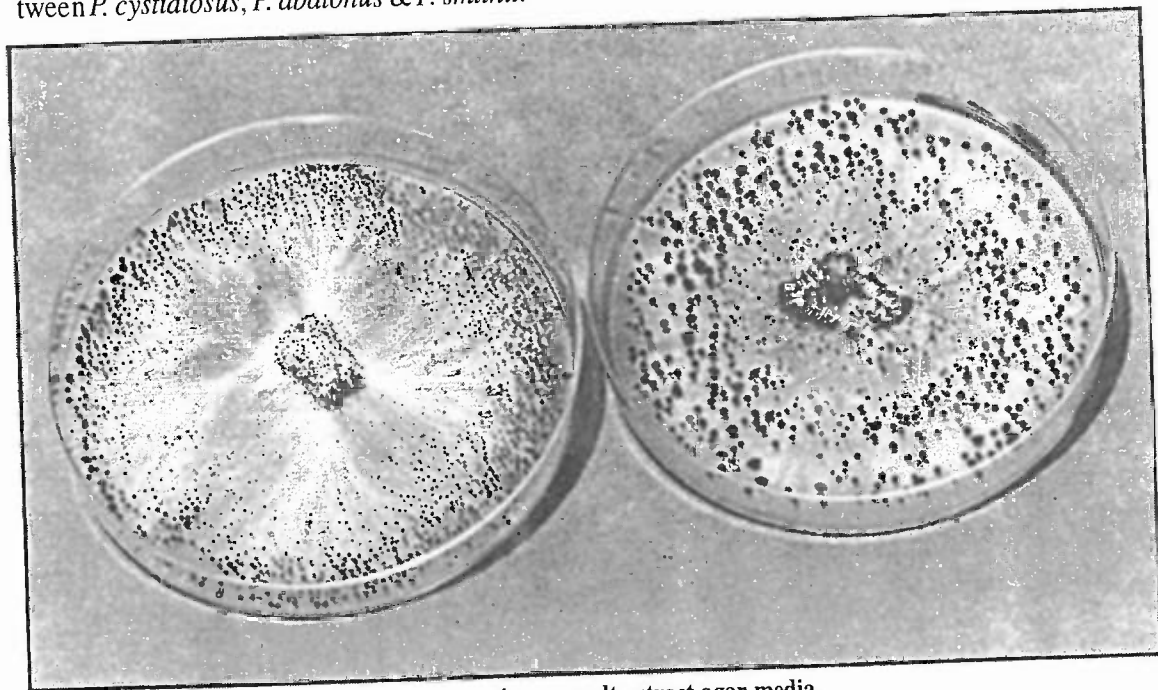

Figure 265. Two strains of *P. cystidiosus* growing on malt extract agar media.

## Growth Parameters

### Spawn Run:

Incubation Temperature: 75-85° F.(24-30° C.)  
 Relative Humidity: 90-95%  
 Duration: 12-16 days.  
 CO<sub>2</sub>: 5000-20,000 ppm  
 Fresh Air Exchanges: 1 per hour.  
 Light Requirements: n/a

### Primordia Formation:

Initiation Temperature: 70-80° F.(18-24° C.)  
 Relative Humidity: 95-100 %  
 Duration: 4-5 days.  
 CO<sub>2</sub>: 500-1000 ppm  
 Fresh Air Exchanges: 4-8 per hour.  
 Light Requirements: 1000-2000 lux.

### Fruitbody Development:

Temperature: 70-80° (90°) F. (21-27° C.)  
 Relative Humidity: 85-90 %  
 Duration: 4-8 days.  
 CO<sub>2</sub>: < 2000 ppm  
 Fresh Air Exchanges: 4-5 per hour.  
 Light Requirements: 500-1000 lux.

### Cropping Cycle:

30 days, two crops, 10 days apart

---

At one time, *P. cystidiosus* was thought, incorrectly to be synonymous with *P. corticatus* (Jong & Peng (1975). This proposed synonymy led to the depositing of several mis-labelled strains into international culture libraries. *P. cystidiosus* is taxonomically discrete from *P. corticatus*. Currently, *P. corticatus* (Fr.:Fr.) Kumm. and *P. dryinus* (Pers.:Fr.) Kumm. are considered synonyms.

**Description:** Cap convex to hemispheric, eventually plane, measuring 2-5 cm. broad, and cream to dingy white in color. (*P. abalonus* is reportedly darker colored. (See Bresinski et al. (1987)). Cap margin often irregular. Gills broad, sometimes widely spaced, strongly decurrent, with irregular edges. Stem thick, central or eccentrically attached and relatively short.

**Distribution:** From the eastern and southeastern United States (Louisiana, Mississippi, North Carolina), Taiwan and South Africa. This mushroom is probably distributed throughout similar ecological zones of the world.

**Natural Habitat:** The type collection made by Dr. O.K. Miller came from Red Maple (*Acer rubrum*). Also native to Eastern Cottonwood (*Populus deltoides*), Sweetgum (*Liquidambar*

---

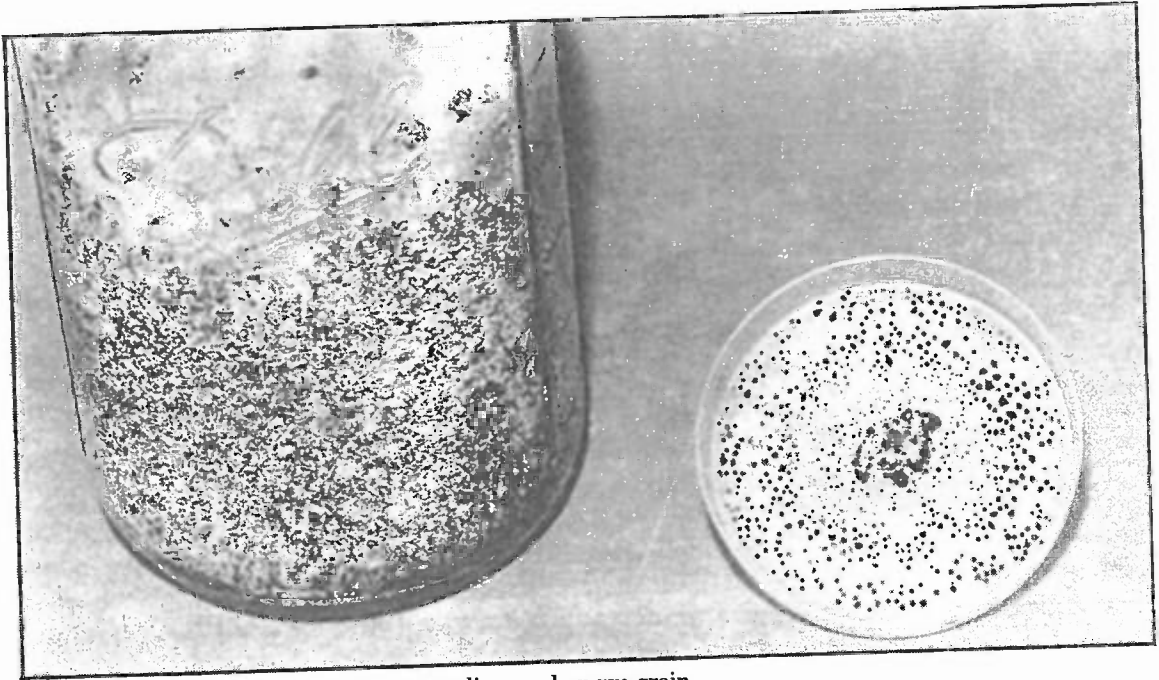

Figure 266. *P. cystidiosus* on malt agar medium and on rye grain.

*styraciflua*), and Asian Oaks (*Quercus nuttalli* & allies).

**Microscopic Features:** Spores white  $11-14 \times 4-5 \mu$ . Hyphal system monomitic. Sterile cells on the cap well developed. The coremic structures on the gills can be seen with a hand lens. Dikaryotic mycelium, capable of producing mushrooms, only arise from two celled conidia. If asexual spores (conidia) are single celled, then the strain is monokaryotic, and incapable of producing fertile mushrooms.

**Available Strains:** Strains are easily obtained from most culture libraries. ATCC # 28599 is the type culture.

**Mycelial Characteristics:** *P. cystidiosus* is the most unusual Oyster mushroom I have seen in culture. At first the mycelium resembles any Oyster strain—white, racing linearly, soon fluffy white and aerial. However, as it grows outwards, black droplets form, radiating outwards from the center as the mycelium matures. (See Figure 265 & 266). These are coremia—stalk-like cells whose tops are fitted with liquid droplets of black spores. The spore-laden black droplets do not pose a contamination threat to other cultures in the laboratory until they dry and harden, at which time they can become airborne. If petri dishes are not handled carefully, the droplets will streak across the media, freeing them. One advantage to the cultivator of this imperfect stage is that inoculation of any substrate with pure culture spawn has an additional complement of asexual spores, effecting a simultaneous “spore mass” inoculation. Colonization is comparatively fast.

**Fragrance Signature:** Musty, farinaceous, not pleasant, not anise-like.

**Natural Method of Cultivation:** Dead or dying maple, cottonwood, sweetgum elms, beeches, oaks

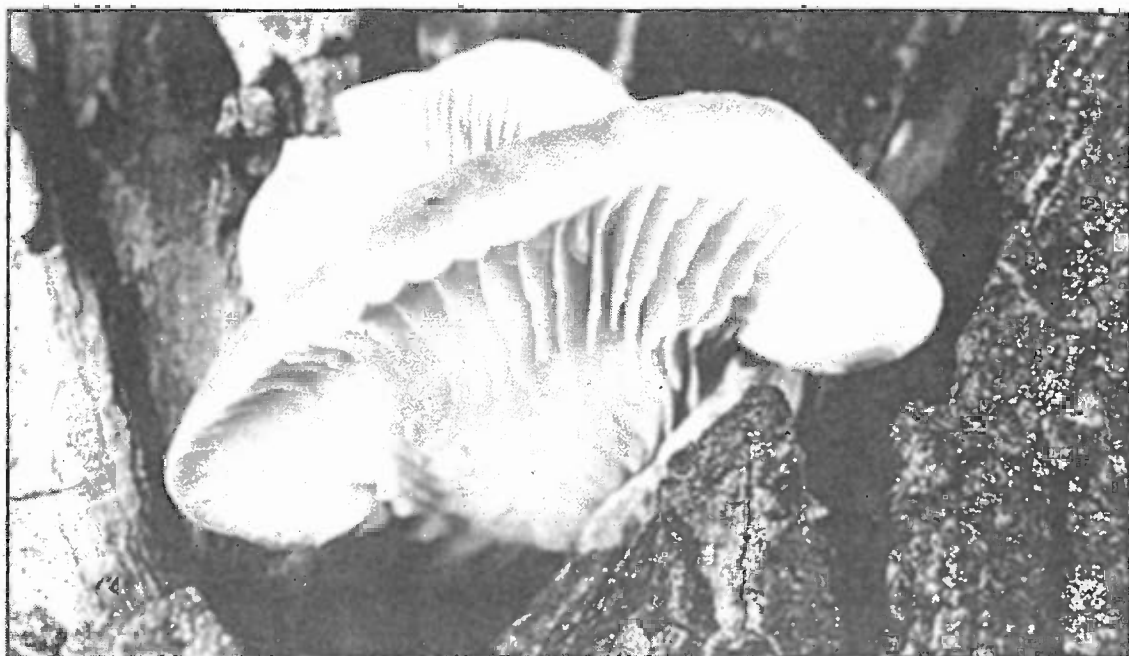

Figure 257. Wild fruiting of *P. cystidiosus*.



Figure 268. *P. cystidiosus* fruiting from bags of sterilized sawdust.

and poplars can be inoculated via plug or sawdust spawn. Stump culture should be possible, given the success with this species close relatives.

**Recommended Courses for Expansion of Mycelial Mass to Achieve Fruiting:** Cultures grown on nutrified agar media can be immersed into sterile water and chopped in a high speed blender for several seconds. The resulting broth can inoculate sterile water fortified with malt/yeast and fermented for 48 hours using the techniques described in Chapter 15. This liquid inoculum is then transferred directly into sterilized grain. Grain spawn should be used within one week of inoculation. No more than two generations of grain spawn are recommended. If the fermentation is continued for 5-7 days, asexual conidia form, facilitating the direct inoculation of bulk substrates.

**Suggested Agar Culture Media:** MYPA, CMYA, DFA or PDYA.

**1st, 2nd and 3rd Generation Spawn Media:** Liquid or grain spawn throughout. Sawdust can be used as the final spawn medium if desired.

**Substrates for Fruiting:** Sterilized hardwood sawdust (maple, oak, beech or elm), pasteurized wheat, rice or paddy straw.

**Recommended Containers for Fruiting:** Bags, columns, trays or bottles.

**Yield Potential:** Biological efficiency rated at 50-75%, higher on sawdust based substrates than on straw.

**Harvest Hints:** Mushrooms should be picked before the caps expand beyond convex. Individual mushrooms can become quite large unless cluster formation is promoted. The stem is edible.

**Form of Product Sold to Market:** Fresh mushrooms and dried are sold in Thailand, Taiwan, China and elsewhere in Asia.

**Nutritional Content:** Not known to this author.

**Medicinal Properties:** Not known to this author.

**Flavor, Preparation & Cooking:** This mushroom can be cooked like most Oyster mushrooms in stir fries, in white sauces or adorning lamb. Please refer to the recipes in Chapter 24.

**Comments:** My experience has been that cultures from Thailand and Taiwan, where this group of mushrooms is commercially cultivated, produce abundantly on rice straw and perform less productively on wheat straw. Strains are more narrowly specific in their fruiting requirements, requiring sustained warmth, and must be more carefully matched with the fruiting substrate than, for instance, *P. ostreatus*, a species more adaptive to a wider variety of materials. For more information, consult Guzman et al.(1991), Jong & Peng (1975), Peng (1974) and Miller (1969).

---



*Pleurotus djamor* (Fries) Boedjin sensu lato

Figure 269. Mycelium of *P. djamor* 5 & 10 days after inoculation onto malt extract agar media.

**Introduction:** This species encompasses a complex of brilliantly pink Oyster mushrooms. The pink Oyster varieties are the most common occurring wild *Pleurotus* in pan-tropical climatic zones of the world. Known for its speed to fruiting, ability to flourish on a wide variety of base materials, and high temperature tolerance, this species is so aggressive as to colonize unpasteurized bulk substrates before competitors can flourish. When growing this mushroom *en masse*, albino clusters sometimes form.

**Common Names:** The Pink Oyster Mushroom  
 The Salmon Oyster Mushroom  
 The Strawberry Oyster  
 The Flamingo Mushroom  
 Takihiro Hiratake (Japanese)  
 Tabang ngungut (Dasun-Northern Borneo)

**Taxonomic Synonyms & Considerations:** This mushroom has a trail of synonyms, when taken as a whole, represent a large complex of pan-tropical varieties. *Pleurotus flabellatus* (Berk. & Br.) Saccardo, *P. ostreato-roseus* Singer and *P. salmoneo-stramineus* Vasil. are included within the *Pleurotus djamor* species complex. Although the mushrooms are usually pink, this color is temporal, sometimes fading as the mushrooms mature.

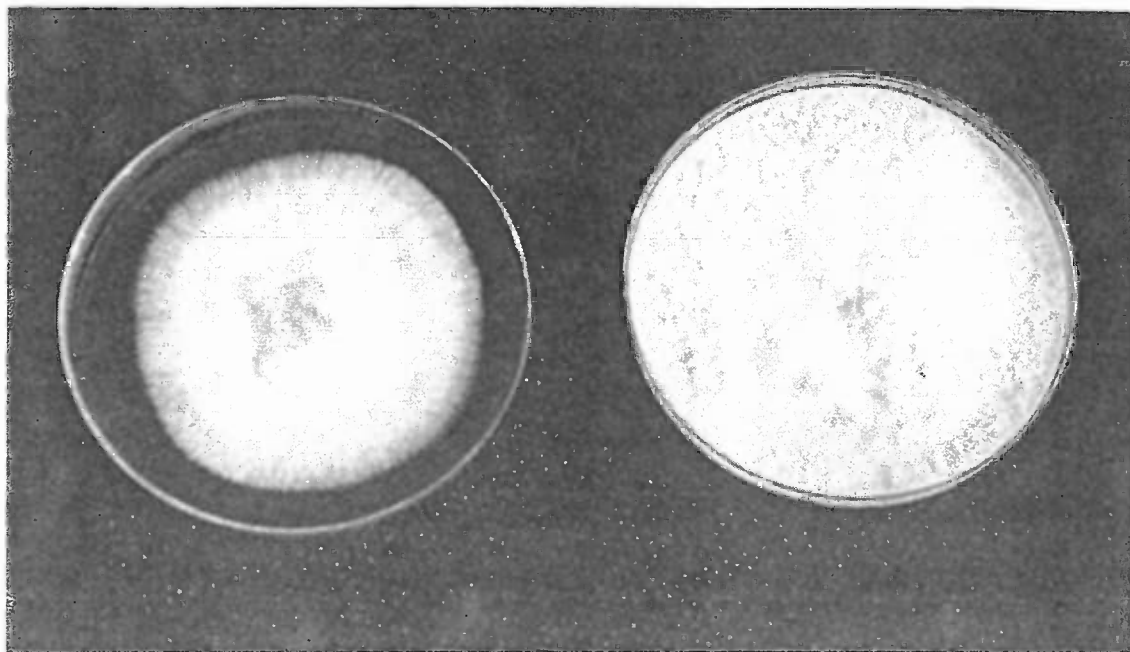
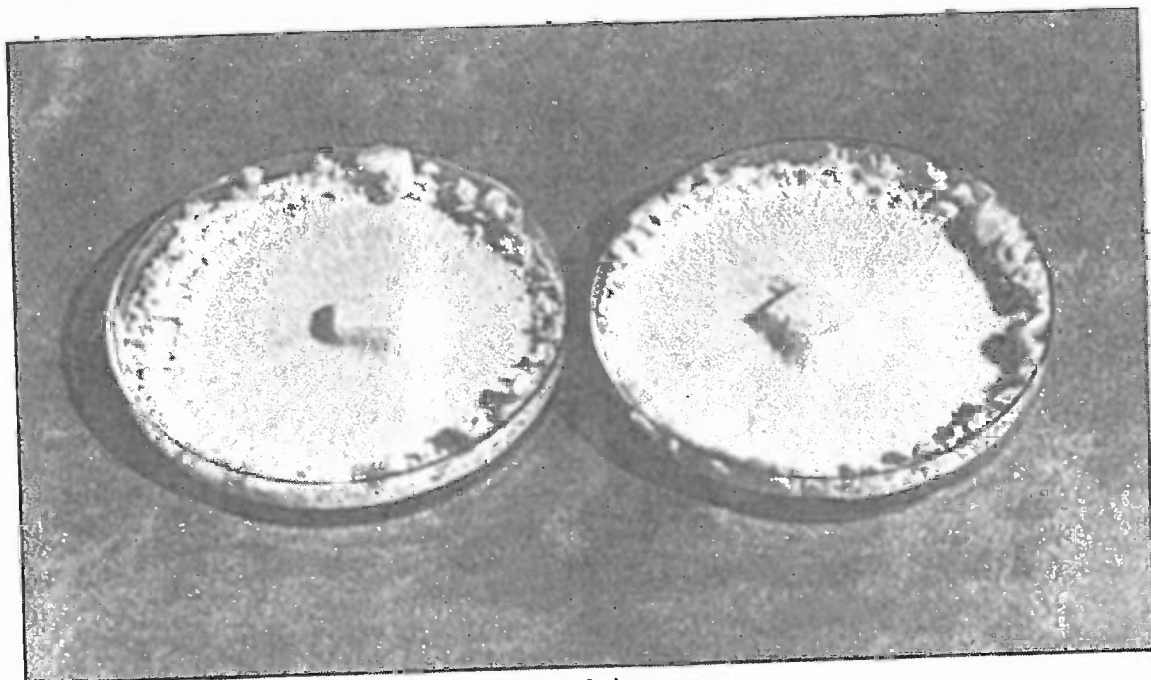

Figure 270. Mycelium of *P. djamor* 14 days after inoculation

Originally published by Fries in 1838 as *Lentinus djamor* Fr., the Friesian concept has been amended to include many varieties. No type collection survived the passage of time. Corner (1981) proposed the pink gilled forms be called *P. djamor* var. *roseus*. He reports that the spores of this variety are cream color. Guzman et al. (1993), calls "*P. djamour*" (sic) synonymous to *P. flabellatus* describing the spores as white to grey to light honey yellow. However, my studies reveal that the color of the fruitbody directly influences the color of the spores. Pink mushrooms give pink spores. White to beige mushrooms, from the same dikaryon that produced the pink mushrooms, gives an off-white to light gray-beige spores. As the pink mushrooms fade with maturity, the spore color also changes. Redhead (1993) suspects this pigment is present in the cytoplasm and not in the outer spore coat.

One contradiction with this proposed synonymy is with the cellular arrangement of the flesh, best seen at the stem base. According to Singer (1986) and Pegler (1983) *P. flabellatus* has a monomitic hyphal system whereas *P. salmoneo-stramineus* has dimitic hyphae. Corner (1981) considers *P. djamor* and *P. flabellatus* synonyms and states that both have dimitic hyphae, in apparent contradiction to Singer and Pegler. Guzman (1993) notes that young specimens of *P. djamor* appear to have monomitic hyphae, with dimitic forms developing in age. *P. ostreato-roseus* Singer is included within the *P. djamor* complex. Another pink Oyster mushroom is the Himalayan *Pleurotus eous* (Berkeley) Saccardo. *P. eous*' relationship to *P. djamor* should be carefully checked for synonymy. They may be the same species. (See Corner (1981), Pegler (1972), and Zadrazil (1993)).

This large group of pink Oyster varieties needs further study. The pink Oyster mushrooms represent a large complex of varieties in a state of rapid convergent and/or divergent evolution. Until DNA

studies are completed, the taxonomy of this group is unlikely to be further resolved by macroscopic or microscopic analyses.

**Description:** Sharing the general shape and appearance of *P. ostreatus* except the primordia are bright reddish ("salmon-egg") pink, becoming pinkish as mushrooms develop, eventually a dull pink to light pinkish cinnamon colored and often fading to straw-colored when over-mature. (The color transitions are not only age-dependent, but vary between strains and are influenced by light conditions.) Cap convex expanding with age to broadly convex to plane. Cap margin inrolled at first, then incurved, and eventually flattening and upturning at maturity. The gills are particularly strongly pigmented with pinkish tones when young, fading to a creamy beige in age. Commonly growing in clusters of multiple mushrooms. When cultivated, variants often appear from the same fruiting container as the pink forms. These variants range in color from beige to cream to white, usually with white to gray gills, and often with a highly undulating, scallop-like cap margin.

**Distribution:** A tropical mushroom complex, widespread throughout the tropics and subtropics. Mushrooms from this group have been collected in Thailand, Cambodia, Singapore, Vietnam, Ceylon, Malaysia, New Guinea, North Borneo, Japan, Brazil, Mexico and the Antilles. A pink Oyster mushroom from Amazonia probably belongs to this species complex.

**Natural Habitat:** Preferring tropical and subtropical hardwoods including palms, rubber trees, and also found on bamboo.

**Microscopic Features:** From the same fruiting column, I obtain pink spores from pink mushrooms



Figure 271. The Pink Oyster mushroom fruiting from bags of sterilized sawdust in Thailand.

and light beige spores from mushrooms that were originally pink but faded to cream beige. Spores measure 6-10 x 4-5  $\mu$ , smooth, and cylindrically shaped. Clamp connections present. Cheilocystidia present. Pleurocystidia absent. Hyphae arranged dimitically.

**Available Strains:** The body of strains available from this complex is mind-boggling. American Type Culture Collection has several cultures, of which ATCC # 34552 (called "*P. salmoneo-stramineus*") is a fruiting strain. (See Figure 272). A strain I have in my culture collection grows extraordinary quickly, producing mushrooms 10 days after inoculation onto pasteurized wheat straw. Cultivators should note that these cultures are often identified by any of the above mentioned names in the discussion of the taxonomy of this mushroom complex.

**Mycelial Characteristics:** White at first, casting a longitudinally linear mycelium, often over-run with long, diverging rhizomorphs, eventually cottony with maturity, and aerial. Most strains soon develop strong pinkish tones, especially as the mycelium matures, at and around the sites of primordia formation. Flaming pink primordia often form as cluster colonies along the inside periphery of the petri dish and/or around the site of inoculation. (See Figure 270). As grain (rye) spawn matures, pink rhizomorphs and mycelia can predominate. A milky gray metabolic exudate collects at the bottom of the incubation containers.

**Fragrance Signature:** At first, the fresh mycelium is similar to *Pleurotus citrinopileatus*, the Golden Oyster Mushroom, in that its fragrance is acrid and has a peculiar "bite" to it. After prolonged storage, the spawn and/or mushrooms develop a rotting fish-like odor. Once dried, the mushrooms impart a more pleasant fragrance.

**Natural Method of Cultivation:** This mushroom can be cultivated on hardwood stumps and logs. Cultivators in Asia have found that this species quickly colonizes unpasteurized cereal straws before contaminants emerge.

**Recommended Courses for Expansion of Mycelial Mass to Achieve Fruiting:** Cultures in petri dishes are cut out, fragmented in a high speed blender, and used to generate grain spawn. Liquid inoculated, 1/2 gallon grain jars are fully grown through in 4-5 days. However, the spawn must be continually expanded to preserve vigor and quality. Liquid-inoculated Grain Masters can be ex-



Figure 272. A variety of the Pink Oyster mushroom which produces unusually large mushrooms from columns of wheat straw.

## Growth Parameters

### Spawn Run:

Incubation Temperature: 75-85° F. (24-30° C.)

Relative Humidity: 95-100%

Duration: 7-10 days.

CO<sub>2</sub>: > 5000 ppm

Fresh Air Exchanges: 0-1 per hour

Light Requirements: n/a

### Primordia Formation:

Initiation Temperature: 65-75° F. (18-25° C.)

Relative Humidity: 95-100%

Duration: 2-4 days

CO<sub>2</sub>: 500-1000 ppm

Fresh Air Exchanges 5-8 per hour.

Light Requirements: 750-1500 lux.

### Fruitbody Development:

Temperature: 70-85° F. (20-30° C.)

Relative Humidity: 85-90%

Duration: 3-5 days.

CO<sub>2</sub>: 500-1500 ppm.

Fresh Air Exchanges: 5-8 per hour.

Light Requirements: 750-1500 lux.

### Cropping Cycle:

2 crops, 7-10 days apart.



panded two more orders of magnitude. Once colonized, the grain spawn should be implanted directly into the fruiting substrate, such as wheat straw. Grain spawn inoculated into pasteurized bulk substrates such as straw at a 10-20% (wet spawn to dry substrate), results in fruitings within two weeks.

**Suggested Agar Culture Media:** MYP, PDYA, OMYA or DFA.

**1st, 2nd and 3rd Generation Spawn Media:** Grain spawn for all three generations.

**Substrates for Fruiting:** Hardwood sawdust, cereal straw, corn waste, coffee residue, cotton waste, banana fronds, palm debris, and sugar cane bagasse. One formula employed by Brazilian growers calls for the proportionate mixing of 100 lbs. sugar cane/ 8 lbs. rice bran/ 3 lbs rice straw/2 lbs. calcium carbonate. The mixture is mixed, wetted, and pasteurized at 140° F. for 2-4 hours. Bano et al. (1978) found that this mushroom (as "*P. flabellatus*") gave the highest yields when cotton seed powder was added at 132 g. per kg. of dry wheat straw. The total mass of the mushrooms grown was 85%

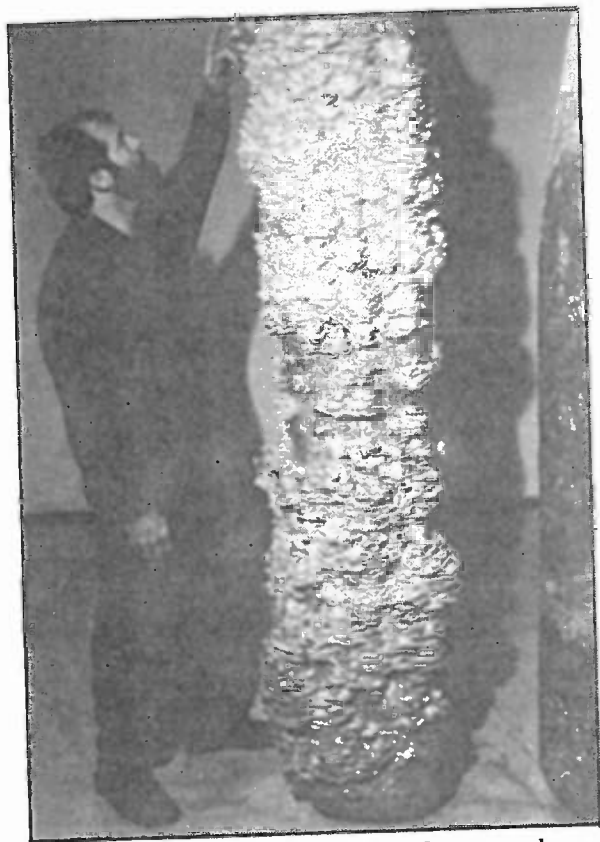

Figure 273. This variety of the Pink Oyster mushroom fruits in only 10 days from inoculation into pasteurized wheat straw.

handled carefully so as to not bruise the brilliantly colored gills. This mushroom spoils rapidly, with a shelf life of no more than 4-5 days from the date of harvest.

**Form of Product Sold to Market:** Fresh or dried. Mushrooms are best presented, gills up, for maximum visual impact. However, the unique pink color makes marketing an interesting challenge depending upon the market niche. In markets like New York and Los Angeles, "pink is hot" and the color, as a friend once told me, "sells itself". As one can imagine, this mushroom may not sell as well as the non-pink varieties in less sophisticated, rural American markets.

**Nutritional Content:** Not fully known to this author. Probably similar to *P. pulmonarius*. Bano et al. (1978) reported that the mushrooms grown from unsupplemented wheat straw compared to wheat straw supplemented with cottonseed powder resulted in protein contents of 30 and 36%, respectively. Supplements and spawning rates have a direct impact on the protein content of the mushrooms grown.

over the yields from unsupplemented wheat straw. Interestingly, the protein content of the dried mushrooms also rose to 38%.

Royse & Zaki (1991) found that the equal addition of the commercially available supplements Spawn Mate II® and Fast Break® at a combined rate of 168 g. per kg. of wheat straw substantially enhanced yields of "*P. flabellatus*". In these tests, biological efficiency increased from 22% to 77% in a 28 day harvest period. I would expect that the yields of other Oyster species would be similarly improved.

**Recommended Containers for Fruiting:** Polyethylene bags or columns, trays, or racks.

**Yield Potentials:** Given good crop management, biological efficiency rated at 75-150%, largely dependent on the age of the fruitbody at harvest. Some strains of this species are equally as productive, in terms of biological efficiency, as the most vigorous strains of *P. pulmonarius* and *P. ostreatus*.

**Harvest Hints:** Mushrooms should be picked when moderately young, and

**Medicinal Properties:** Not known to this author.

**Flavor, Preparation & Cooking:** The flavor of this mushroom is not as appealing as many of the other Oyster species listed in this book. Tougher fleshed and more tart than other Oyster species, the pink color soon disappears upon contact with heat. Upon drying, a majority of (but not all) specimens lose their pinkish tones. Although this mushroom is not my personal favorite, some of my students prefer it over *P. ostreatus* and *P. pulmonarius*.

**Comments:** This complex of Pink Oyster Mushrooms hosts some of the fastest growing strains of mushrooms in the Genus *Pleurotus*. For those with limited access to pasteurization equipment, and living in a warm climate, strains of *P. djamor* uniquely fulfill a critical need. Its speed of colonization, short but productive fruiting cycle, and adaptability to diverse substrate materials, make this species affordable to many cultivators, especially those in developing countries.

Zadrazil (1979) noted that this mushroom (as "*P. flabellatus*") and *Stropharia rugoso-annulata* proved to be the best at rendering straw, after fruiting, into a nutritious feed staple for ruminants, especially cattle. (For more information of utilizing "spent" straw from Oyster mushroom cultivation into feed for animals, see page 283).

For more information, please consult: Bononi et alia, 1991, "*Pleurotus ostreatoroseus* cultivation in Brazil". Mushroom Science XI, A.A. Balkema, Netherlands.

---

*Pleurotus eryngii* (De Candolle ex Fries) Quelet sensu lato

Figure 274. *P. eryngii* mycelia 5 and 10 days after inoculation onto malt extract agar media.

**Introduction:** *Pleurotus eryngii* is by far the best tasting Oyster mushroom, well deserving of the title, the King Oyster. Popular in Europe, this stout, thickly fleshed mushroom, is one of the largest species in the genus. Preferring hardwoods, this mushroom is easy to grow. Although this mushroom grows on the cereal (wheat) straws, the yields are not as substantial as that of *Pleurotus ostreatus* and *Pleurotus pulmonarius* on this same material, at the same rate of spawning, unless supplements are added or a unique spawning method is employed.

**Common Names:** The King Oyster  
Boletus of the Steppes\*

**Taxonomic Synonyms & Considerations:** Synonymous with *Pleurotus fuscus* (Batt.) Bres. Varieties specific to ecological niches has been commented upon by Bresinsky et al. (1987) and although these varieties appear morphologically identical, the distribution of ecotypes are quite distinct.

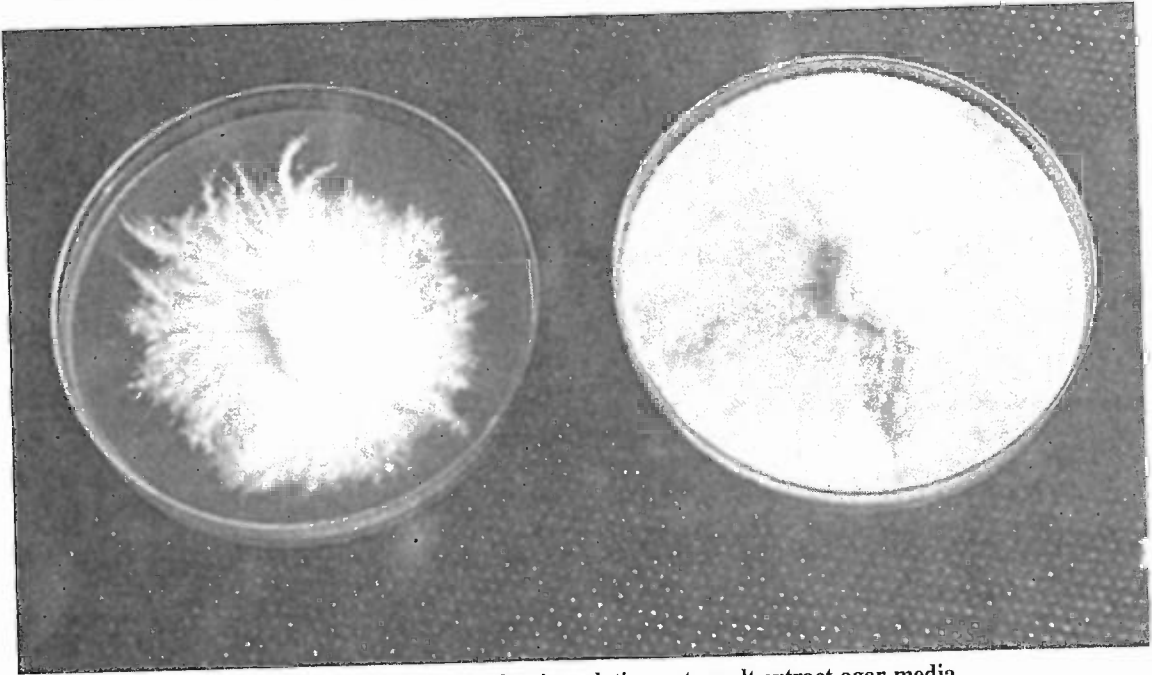
**Description:** Cap 3-12 cm. in diameter, at first convex, expanding with age, becoming funnel-shaped, with the margin typically inrolled, extending with age. Stem 3-10 cm. in length, central, thick, tapering downwards. Gills fairly distant, thin, grayish, and decurrent. Growing individually or in small groups. Cultivated mushrooms achieve a greater stature and overall size compared to ones collected in the wild.

\* According to Zadrazil, Vasilkov called this mushroom "Boletus of the Steppes" a name I find to be quite peculiar.





Figure 275 and 276. *P. eryngii* fruiting from supplemented alder sawdust/chips.

**Distribution:** Throughout southern Europe, North Africa, central Asia and the southern Soviet Union.

**Natural Habitat:** Terrestrial, growing on the buried roots of hardwoods. This mushroom is thought to be a facultative parasite on dying *Eryngium campestre*, a member of the carrot family.

**Microscopic Features:** Spores white, ellipsoid, 10-14 x 4-5  $\mu$ . Clamp connections present. Context monomitic.

**Available Strains:** Most strains originate from Europe and are available from many culture libraries.

**Mycelial Characteristics:** Whitish, longitudinally radial at first, sometimes rhizomorphic, soon thickening and becoming cottony in age.

**Fragrance Signature:** Grain spawn and myceliated straw smells rich, sweet, and classically Oysteresque but not anise-like.

**Natural Method of Cultivation:** Outdoors, on log sections turned vertically, and on stumps inoculated with plug spawn. This species is easily grown on straw outdoors using the mound method. Some strains are native to conifers (*Abies* spp.). If brought into culture, these races could help recycle conifer stumps throughout the world.

**Recommended Courses for Expansion of Mycelial Mass to Achieve Fruiting:** Traditional or liquid inoculation of grain spawn which is then broadcasted into fruiting substrates, preferably sterilized

sawdust. Pasteurized straw cultivation is comparatively less productive unless inoculated with equal quantities of sawdust and grain spawn. In other words, every ton of wheat straw (2000 lbs. dry weight) should simultaneously receive 100 lbs. of grain spawn (wet weight) and 100 lbs. of sawdust spawn (wet weight). This combination spawning method gives rise to large specimens on wheat straw.

**Suggested Agar Culture Media:** MYPA or PDYA.

**1st, 2nd and 3rd Generation Spawn Media:** Rye, wheat, sorghum, milo, or millet.

**Substrates for Fruiting:** Most hardwoods, wheat straw, and cottonseed hulls support fruitings. This mushroom is not as adaptive as *P. pulmonarius* and *P. ostreatus* to a broad range of substrates. Nevertheless, many materials can be used. I have been pleased with its performance on recycled, re-sterilized waste Shiitake substrate. However, I would not recommend this approach for commercial

purposes unless the preferred wood type or alternative substrate materials were exceedingly scarce or cost-prohibitive. If cultivating this mushroom on wheat straw, the addition of 5-10% cottonseed meal reportedly has the greatest effect in enhancing yield. (Upadhyay & Vijay, 1991)

**Recommended Containers for Fruiting:** Trays, plastic bags, columns, or bottles.

**Yield Potentials:** 1 lb. of mushrooms per 5 lbs. of sterilized sawdust/chips/bran. Wheat straw fruitings, from my experience, have tallied approximately 1/2 of that from enriched sawdust. The stage at which the mushrooms are picked significantly affects yield efficiencies.

**Harvest Hints:** This mushroom can become quite large if the substrate has a sufficient nutritional base. The stage at which the fruitbody should be picked will depend largely upon the strain and the cultivator's preference. When the cap margins are inrolled or deeply incurved, the mushrooms are at an adolescent stage and are likely to grow much larger. I prefer harvesting the mushrooms just before the cap margin flattens.

**Form of Product Sold to Market:** Wild mushrooms are sold in markets in Spain, Morocco and other southern European countries.

**Nutritional Content:** Not known although expected to be similar to or exceeding *P. ostreatus*.

**Medicinal Properties:** Not known.



Figure 277. LaDena Stamets about to harvest *P. eryngii* from column of pasteurized wheat straw.

## Growth Parameters

### Spawn Run:

Incubation Temperature: 75° F. (24° C.)  
 Relative Humidity: 90-95%  
 Duration: 12-16 days.  
 CO<sub>2</sub>: 5000-20,000 ppm  
 Fresh Air Exchanges: 1 per hour.  
 Light Requirements: n/a

### Primordia Formation:

Initiation Temperature: 50-60° F. (10-15° C.)  
 Relative Humidity: 95-100%  
 Duration: 4-5 days.  
 CO<sub>2</sub>: 500-1000 ppm  
 Fresh Air Exchanges: 4-8 per hour.  
 Light Requirements: 500-1000 lux.

### Fruitbody Development:

Temperature: 60-70° F. (15-21° C.)  
 Relative Humidity: 85-90%  
 Duration: 4-8 days.  
 CO<sub>2</sub>: < 2000 ppm  
 Fresh Air Exchanges: 4-5 per hour.  
 Light Requirements: 500-1000 lux.

### Cropping Cycle:

45 days, two crops, 14 days apart

**Flavor, Preparation & Cooking:** Stir frying until edges become crispy golden brown. A chewy, nutty mushroom, this species is far superior to *P. ostreatus* and *P. pulmonarius*. This mushroom, like other Oyster mushrooms, goes well with Italian dishes, and especially with lamb, pork and fish.

**Comments:** The King Oyster's stout form, short gills, and thick flesh, coupled with its pleasing flavor strongly commends this species amongst connoisseur growers and chefs. The short gills mean this mushroom releases comparatively fewer spores per lb. of harvested mushrooms, a significant advantage over other Oyster species. Gary Lincoff (1990) reported that this mushroom received the highest acclamations of any of the mushrooms tasted during a culinary tour of mycophagists sampling the treasured mushrooms of Europe. This is the only Oyster species I know that ships well over long distances and has an extended shelf life.

Although a casing layer has been recommended by other cultivators, I have found its application to

be unnecessary. My best fruitings of *Pleurotus eryngii*, both in terms of yields and quality, has been on 20% bran-enriched alder sawdust. Three weeks after inoculation with grain spawn, the fully colonized bags of sterilized sawdust/chips/bran are brought into the growing room. The top of the bags are horizontally sliced opened, resulting in a 3-4 inch plastic wall around and above the surface plane of the mycelium. In effect, these side walls protect the supersensitive aerial mycelium from sudden dehydration. Condensation is promoted. Coupled with a descending fog environment within the growing room, the perfect microclimate for primordia formation is provided.

Zadrazil (1974) showed mycelial growth peaked when carbon dioxide levels approached 220,000 ppm. or 22%. The stimulatory effect of CO<sub>2</sub> on mycelial growth allows this mushroom to grow under conditions which would be stifling for most other mushrooms and lifeforms. Optimum pH levels at the time of spawning should be between 7.5-8.5. On wheat straw, the pH naturally declines to a range of 5.5-6.5, a range ideal for fruiting.

---

*Pleurotus euosmus* (Berkeley apud Hussey) Saccardo

Figure 278. *P. euosmus* mycelia 3 and 10 days after inoculation onto malt extract agar media.

**Introduction** The Tarragon Oyster mushroom is closely related to *Pleurotus ostreatus*. According to Watling & Gregory (1989), this mushroom is generally considered a form or variety of *P. ostreatus*, but differs in the strong smell of tarragon. It has been reported, to date, from England and Scotland. *P. euosmus* behaves, in culture, similarly to *P. ostreatus*.

**Common Names:** The Tarragon Oyster Mushroom.

**Taxonomic Synonyms & Considerations:** *Pleurotus euosmus* can be distinguished from *P. ostreatus* by its odor (tarragon) and by spore size. The spore size of *P. euosmus* is 12-14  $\mu$  substantially larger than the 7.5-11  $\mu$  spores of the European *P. ostreatus* collections. However, I would not be surprised that these taxa are found to be conspecific through interfertility or DNA studies. Hilber (1989) suggests synonymy between these two taxa without elaboration. The morphology of this mushroom—with its depressed cap at maturity and long running gills—bears strong resemblance to *Pleurotus ostreatus*.

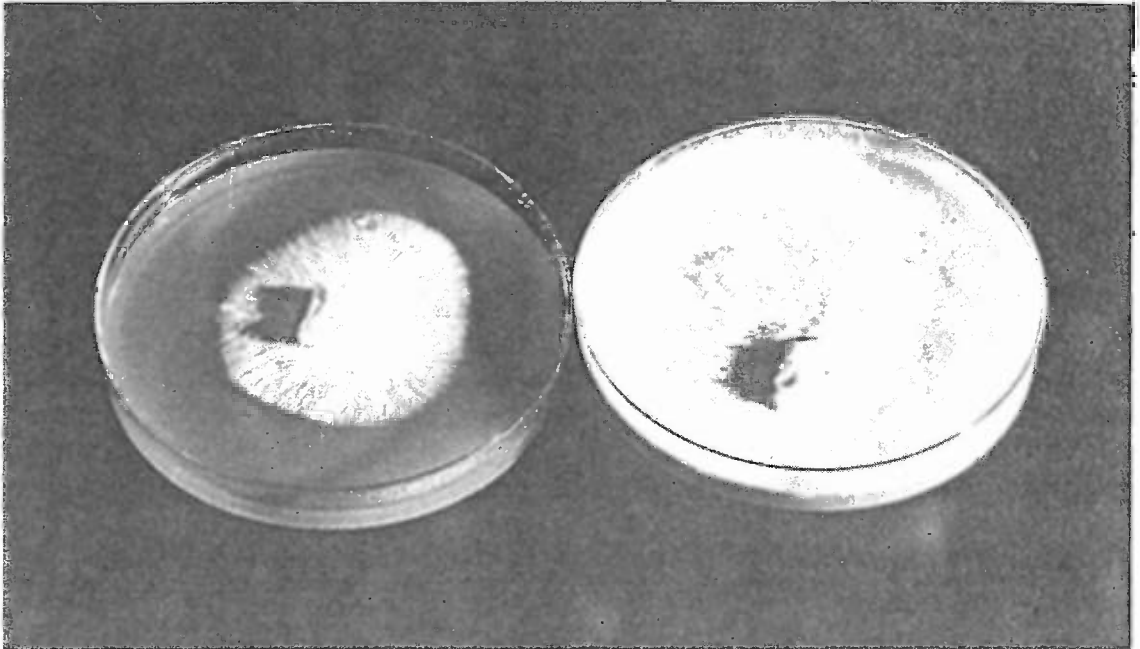
*Pleurotus eous* (Berkeley) Saccardo is a discretely separate species from *P. euosmus* and is more closely allied to the pink *P. djamor* varieties than to the gray brown *P. ostreatus* and allies. (See Pegler (1972) and Corner (1981)). Chang & Miles make reference to nutritional analysis of "*Pleurotus eous*" in *Edible Mushrooms & their Cultivation* (1987, pg. 28) without further elaboration. See also the taxonomic discussions of *P. djamor* and *P. ostreatus*.

**Description:** Cap 5-15 cm. broad, convex at first, soon broadly convex, expanding to plane, and typically deeply depressed in the center. Mushrooms beige-tan at first, becoming dingy brown with time, sometimes with a hint of blue, becoming light beige tawny in age. Margin even at first, often irregular in age. Gills dingy, decurrent, broad, running deeply down the stem. Stem short or sometimes absent.

**Distribution:** Limited to the British Isles, known from England and Scotland, but not yet reported from Ireland.

**Natural Habitat:** Preferring Elms (*Ulmus* species) stumps and logs.

**Microscopic Features:** Spores pale pinkish lilac, oblong and narrow, measuring 12-14 x 4-5  $\mu$ . Otherwise similar to *P. ostreatus*.

**Available Strains:** Strains are available from some British, European and American culture libraries.

**Mycelial Characteristics:** White, longitudinally linear, cottony, aerial fast growing and classically Oysteresque. Soon after colonizing a petri dish of MYPA, the mycelium tears off in thick sheets.

**Fragrance Signature:** Sweet, pleasant, slightly anise-like, virtually identical to *P. ostreatus*.

**Natural Method of Cultivation:** I know of no one purposely growing this mushroom outdoors. However, given its close affinity to *P. ostreatus* and that it is native to Elm stumps, this mushroom is likely to produce prodigiously using the Natural Culture techniques described in this book.

**Recommended Courses for Expansion of Mycelial Mass to Achieve Fruiting:** Transfer cultures from nutrified agar media into sterilized water and blend in a high speed stirrer for several seconds. This liquified mycelium then inoculates sterilized grain. Once colonized, grain spawn can be introduced directly into pasteurized straw or sterilized sawdust.

**Suggested Agar Culture Media:** MYA, MYPA, PDYA or OMYA.

**1st, 2nd and 3rd Generation Spawn Media:** Grain spawn for the first two generations, hardwood sawdust spawn for the final stage.

**Substrates for Fruiting:** Hardwood sawdust, cereal straw, cottonseed hulls, sugar cane bagasse, coffee wastes, paper by-products, and many other materials. This mushroom will probably grow on many more substrate materials given modest experimentation.



Figure 279. *P. euosmus* fruiting from pasteurized wheat straw.

---

## Growth Parameters

### Spawn Run:

Incubation Temperatures: 70-80° F. (21-27° C.)  
Relative Humidity: 98-100%  
Duration: 7-14 days  
CO<sub>2</sub>: > 10,000 ppm.  
Fresh Air Exchanges: 0-1 per hour  
Light Requirements: n/a

### Primordia Formation:

Initiation Temperature: 65-75° F. (18-24° C.)  
Relative Humidity: 95-100 %  
Duration: 7-10 days  
CO<sub>2</sub>: < 2000 ppm  
Fresh Air Exchanges: 4-8 per hour  
Light Requirements: 750-1500 lux.

### Fruitbody Development:

Temperature: 70-80° F. (21-27° C.)  
Relative Humidity: 90-95%  
Duration: 4-8 days.  
CO<sub>2</sub>: < 1000 ppm  
Fresh Air Exchanges: 4-8 per hour  
Light Requirements: 750-1500 lux.

### Cropping Cycle:

3 crops two weeks apart.

---

**Recommended Containers for Fruiting:** Bags, bottles, columns and trays.

**Yield Potentials:** 75-100% biological efficiency, greatly affected by the size of the mushrooms at harvest, and the number of flushes allowed.

**Harvest Hints:** Mushrooms should be harvested before heavy sporulation. Since this mushroom strongly resembles *Pleurotus ostreatus* in terms of biology and appearance, the same guidelines for picking should be followed.

**Form of Product Sold to Market:** Fresh, dried and powdered.

**Nutritional Content:** 25% crude protein; 59% carbohydrates; 12% fiber, 9% ash; and 1.1% fat.

**Medicinal Properties:** Not known to this author. Probably similar to *P. ostreatus*.

**Flavor, Preparation & Cooking:** Versatile and flavorful, this mushroom can be incorporated into a wide variety of recipes. I prefer to saute young mushrooms at high heat in a light oil and to add cash-

---

ews or almonds along with onions to adorn white fish or salmon which is then baked. Please refer to the recipes in Chapter 24.

**Comments:** The cultivation of *Pleurotus euosmus* parallels the cultivation of *P. ostreatus* and grows at a mid-level temperature range, not requiring a cold shock to initiate. The cultures in my collection produce uniform, medium sized fruitbodies specific to puncture holes in the containers. Clusters of 5-10 mushrooms are common, rarely numbering more, with the majority of the primordia forming reaching full maturity. These features may be strain specific. Please refer to the discussion of *P. ostreatus*, a close relative and possible future synonym of this mushroom.

---

---



*Pleurotus ostreatus* (Jacquin ex Fries) Kummer

Figure 280. *P. ostreatus* mycelia 4 and 10 days after inoculation onto malt extract agar media.

**Introduction:** The prototypic Oyster mushroom, *Pleurotus ostreatus* has long been a favorite of mushroom hunters, especially in the spring time in lowland, hardwood forests. A prolific producer on a wide array of substrates, strains of this species are plentiful and easy to grow. Enjoying a worldwide reputation, specimens of extraordinary size have been collected from the wild. For instance, in the fall of 1988 near the north coast of Sicily, Salvatore Terracina, a farmer, collected a *P. ostreatus* nearly 8 ft. in circumference, 20 inches thick, and weighing 42 lbs! For the prepared and astute cultivator, cloning this monster could have resulted in an extraordinarily productive strain.

**Common Names:** The Oyster Mushroom, Oyster Shelf, Tree Oyster  
Straw Mushroom  
Hiratake (Japanese for "Flat Mushroom")  
Tamogitake (Japanese)

**Taxonomic Synonyms & Considerations:** *Pleurotus ostreatus* is the type species for the Genus *Pleurotus* and represents a huge complex of subspecies, varieties and strains. Comparisons with other taxa is compounded by the fact many strains labelled as *P. ostreatus* are in fact *P. pulmonarius* and vice versa. For a mushroom so widely cultivated, I am surprised (and relieved) that only recently has the taxonomy become clearer, largely through the works of Petersen, Vilgalys and Hilber.

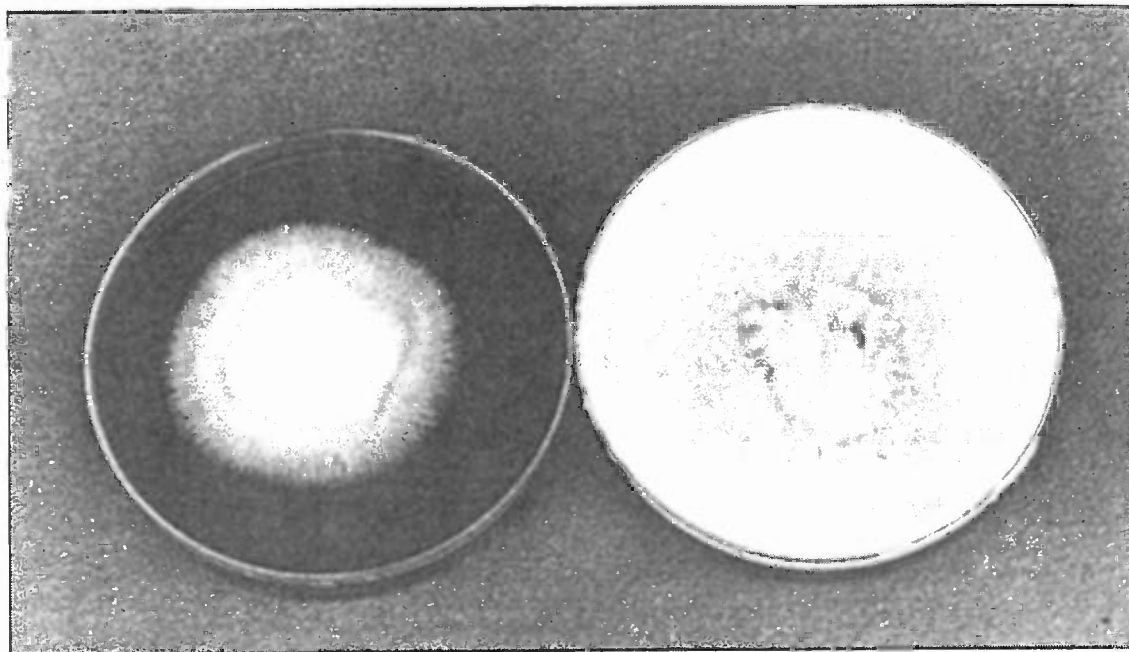
*Pleurotus ostreatus* is so similar to *P. pulmonarius* that they are difficult to separate macroscopically. The western collections of Oyster mushrooms on conifers usually fall into *P. pulmonarius*

species concept. Furthermore, when *P. pulmonarius* is found wild in the west, it prefers the higher altitude, drier coniferous forests to the hardwood, river-bottoms where *P. ostreatus* dominates. Furthermore, *P. pulmonarius* is primarily found in the spring to early summer whereas *P. ostreatus* is common from the spring through late fall. A recently named species, *P. populinus* Hilber & Miller has a marked preference for black cottonwood (*Populus trichocarpa*) and aspen (*Populus tremelloides* and *P. tridentata*) Unlike *P. ostreatus*, *P. populinus* has, according to Vilgalys et al. (1993), a buff-colored, non-lilac spore print and larger spores, measuring 9-12 x 3-5  $\mu$ .

An Oyster strain from Florida, *Pleurotus florida* Eger is considered by this and other authors to be a synonym of *P. ostreatus* because spores from each species are cross fertile, the mycelium forms clamp connections, and mushrooms grown from this mating produce fertile fruitbodies. The Florida variety differs primarily in its preference for warmer temperatures at fruiting, i.e., 75° F. (24° C.) and above. (See Li & Eger, 1978). Guzman (1993) suggests that *P. florida* is conspecific with *P. pulmonarius*. Others believe *P. florida* is merely a variety of *P. ostreatus*. Hilber (1982) noted that the original strain of Eger's *P. florida* is, in fact, interfertile with *P. ostreatus*. Vilgalys (1993) concurs with Hilber, but solely on the basis of DNA comparisons. In our book, *The Mushroom Cultivator* (Stamets and Chilton (1983), I incorrectly suggested synonymy between *P. florida* and *P. floridanus*, the latter being a distinctly separate species moved to the Genus *Lentinus* by Pegler (1983).

Another sometimes bluish Oyster mushroom called *Pleurotus columbinus* is also in doubt as a separately valid species. Singer proposes *Pleurotus columbinus* to be a variety of *P. ostreatus*, i.e. *P. ostreatus* var. *columbinus* (Quel. apud Bres.) Quel. This placement concurs with the long held view of many cultivators. One feature of this variety is its nearly perfect, even cap margin and broadly convex cap. The North American *Pleurotus sapidus* also shares synonymy with *P. ostreatus*, according to Vilgalys et al. (1993).

Unless comparative DNA techniques are employed, or interfertility studies between known species are conducted, mistaken identifications between these taxa are likely. Those cloning wild specimens are therefore encouraged to retain a dried specimen for future verification of identification. For more information, please consult Hilber (1982), Kay & Vilgalys (1992), Petersen & Hughes (1992), and Vilgalys et al. (1993).

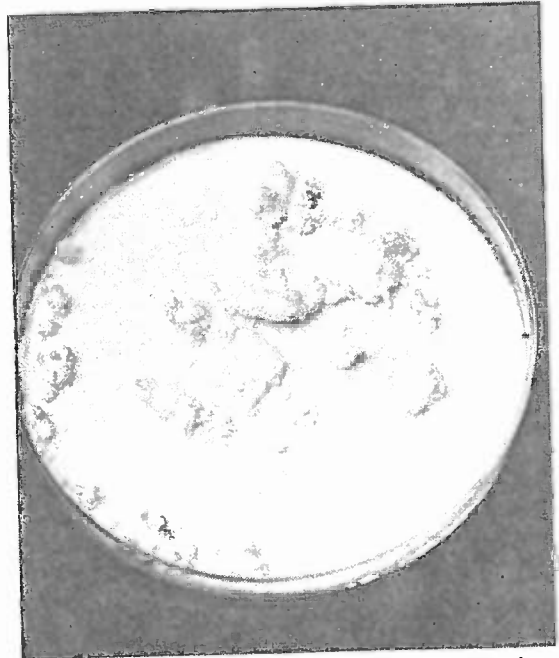

Figure 281. *P. ostreatus* mycelium 21 days after inoculation.



Figure 282. A sporeless strain of *P. ostreatus*. Under the microscope, the gill planes are entirely free of basidia.

**Description:** Cap convex at first, expanding to broadly convex, eventually flat and even up-turned in age. 5-20 cm. (+) in diameter. White to yellow to grayish yellow to tan, rarely with pinkish tones, to lilac gray to gray-brown. Cap margin smooth to undulating like an Oyster shell. Color varies according to the strain, lighting, and temperature conditions. Stems are typically eccentrically attached to the cap. Flesh generally thin. Some strains form clusters; others form individuals.

**Distribution:** Distributed throughout the temperate and tropical forests of the world.

**Natural Habitat:** Common on broad-leaf hardwoods in the spring and fall, especially cottonwoods, oaks, alders, maples, aspens, ash, beech, birch, elm, willows and poplars. (From an evolutionary point of view, this mushroom has been very successful, given its ability to saprophytize a broad range of tree species.) Although seen on dying trees, *P. ostreatus* is thought to be primarily a saprophyte, but behaves as a facultative para-

site at the earliest opportunity. Occasionally occurring on composting bales of straw, and in Mexico, on the waste pulp from coffee production. (The occurrence of *P. ostreatus* on this last habitat might be a result of this species escaping from the woodland environment and taking advantage of a niche provided by the coffee industry.) *P. ostreatus*, and particularly *P. ostreatus* var. *columbinus*, are occasionally found on conifers, especially *Abies*. The most abundant fruitings of this species is in low valley riparian habitats.

**Microscopic Features:** Spores white\* to slightly lilac to lilac grey, 7.5-9.5 x 3-4  $\mu$ . Clamp connections present. Context monomitic.

**Available Strains:** The genome of strains for this species is vast and increasingly explored by home and commercial cultivators. Cold and warm weather strains are available from numerous culture libraries. Amycel's #3001 and Penn State's # MW44, cold weather strains, are popular. A warm weather strain I cloned from mushrooms growing on a fallen oak in a ravine near San Diego, produces an attractive, white mushroom in as short as 10-12 days from inoculation onto wheat straw. (See Figure 285).

\* From my experiences, Oyster mushrooms from river-bottom habitats in western Washington and Oregon produce a white to grey buff spore print, and not distinctly lilac as reported for the eastern forms. Furthermore, I have recently collected a pale rose variety of *P. ostreatus* on alder (*Alnus rubra*) from western Washington which I have never encountered before. The pale rose color has been described for *P. pulmonarius*, but not for *P. ostreatus*.



Figure 283. A dark, cold weather strain of *P. ostreatus* fruiting 21 days after inoculation onto wheat straw. Note primordia form specific to punctures in plastic.

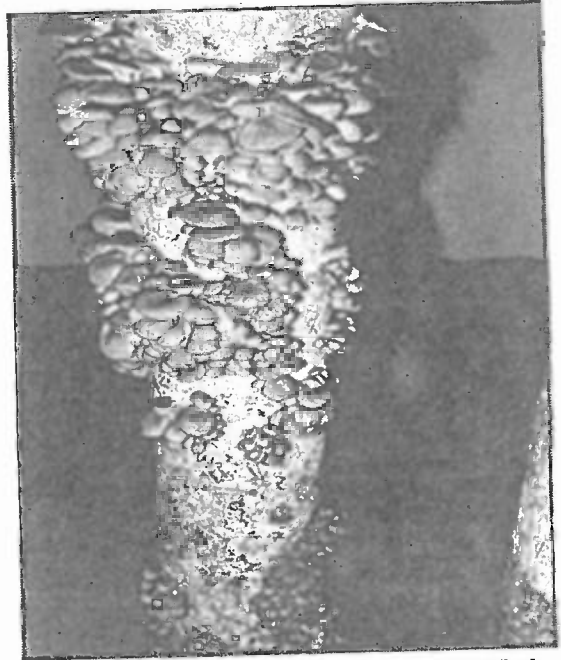

Figure 284. The same column 24 hours later. Mushrooms are ready for harvest.

The same strain produces a brown capped mushroom at cold temperatures, a reaction typical of most Oyster varieties. "Spore-less" strains have obvious advantages for indoor cultivation, especially if the long gestation period before fruiting can be shortened. (See Figure 282). One sporeless strain available from the French-based Somycel company is # 3300. For more information on sporeless strains, and how to develop them, consult the article by Imbernon & Labarere (1989).

**Mycelial Characteristics:** Whitish, longitudinally radial, soon becoming cottony, and in age forming a thick, tenacious mycelial mat. Aged mycelium often secretes yellowish to orangish droplets of a metabolite which is a toxin to nematodes. This metabolite deserves greater study.

**Fragrance Signature:** Sweet, rich, pleasant, distinctly anise and almost almond-like.

**Natural Method of Cultivation:** On logs or stumps outdoors. Pagony (1973) reported that, on average, more than 1 lb. of mushrooms per year was harvested from inoculated poplar stumps for more than 3 years. Of the 200 poplar stumps, ranging in size from 6-12 inches, that were inoculated in the spring, all produced by the fall of the following year. As expected, hardwoods of greater density, such as oak, took longer to produce but sustained yields for a greater period.

**Recommended Courses for Expansion of Mycelial Mass to Achieve Fruiting:** Agar-to-grain-to-cereal straw, or agar-to-grain-to-supplemented, sterilized sawdust. Since this mushroom thrives under liquid culture conditions, spawn generated by these methods is highly recommended. See Chapter 15.

**Suggested Agar Culture Media:** MYPA, PDYA, OMYA or DFA. Optimal growth seen at pH 5.5-6.5.

**1st, 2nd & 3rd Generation Spawn Media:** Rye, wheat, milo, sorghum, corn, & millet. Sawdust spawn is not needed for indoor cultivation methods. However, sawdust spawn is ideal in the inoculation of stumps and logs in outdoor settings.

**Substrates for Fruiting:** A wide array of agricultural and forest waste products can be used, including but not limited to: straw (wheat, rye, oat, rice, and barley straw); corn stalks, sugar cane bagasse; coffee pulp; banana waste; cotton waste & cottonseed hulls; hardwood sawdusts; paper by-products; soybean waste; palm oil by-products; agave waste; and even the pulp remaining from tequila production! The pH at make-up can vary between 6.0-8.0 but should fall to an optimum of 5.0 at fruiting for maximum biomass production. (See El-Kattan et al., 1990.)

Martinez et al. (1985) reported yields of 132% biological efficiency (4 flushes) from coffee pulp that was fermented for 5 days, pasteurized, and inoculated with wheat grain spawn. Further, they found residual caffeine from the spent substrate was reduced by more than 90%. (Caffeine represents a significant toxic waste to streams in coffee growing regions of the world.) Martinez-Carrera (1987) validated the results with yields in excess of 100% biological efficiency on the same substrate and presented the first model for utilizing this abundant waste product.

Platt et al. (1982) published studies on the utility of cotton straw as a substrate for this mushroom. Their yields average 600-700 grams per kilogram of dry cotton straw, in other words 60-70% biological efficiency.

**Yield Potentials:** 75-200% biological efficiency, greatly affected by the size of the fruitbodies harvested, and the number of flushes orchestrated.

**Harvest Hints:** Mushrooms should be picked when young, and preferably in clusters. Once the gills produce abundant spores, storageability rapidly declines. Workers should wear filter masks effective down to 7 microns to eliminate the inhaling of spores. Mushroom surfaces should be slightly dry at harvest. Mushrooms should be chilled first to 35° F. (1-2° C.) and then placed into end-user containers (for restaurants or consumers) and covered with breathable, anti-condensate plastic film.

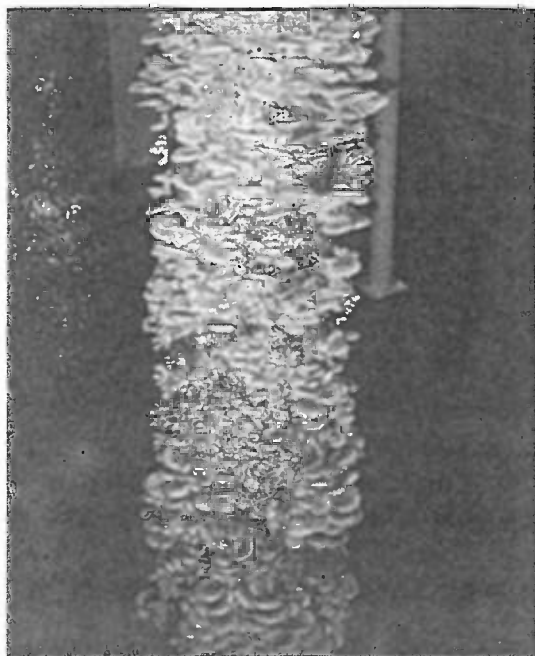

Figure 285. A white Oyster variety of *P. ostreatus* isolated from southern California that fruits 10 days from inoculation onto wheat straw.

**Form of Product Sold to Market:** Fresh and dried mushrooms. Waste straw substrate has been test marketed as a cattle feed.

**Nutritional Content:** Crude protein: 10-30%. Vitamins C: 30-144 mg/100 g; Niacin: 109 mg/100g; Folic Acid: 65 mg/100 g. High in potassium: 306 mg/100 g. For further information, see Bano & Rajarathnam (1982), Miles & Chang (1986), and Rai et al. (1988).

**Medicinal Properties:** Recent studies (Gunde-Cimerman et al., 1995) show that *Pleurotus ostreatus* and other closely related species naturally produce Lovastatin<sup>®</sup> (3-hydroxy-3-methylglutaryl-coenzyme A reductase), a drug approved by the FDA in 1987 for treating excessive blood cholesterol. More Lovastatin is present in the caps than in the stems, more concentrated on the mature gills, and especially in the spores. This compound and others related to it may explain the often reported cholesterol-lowering effects of many woodland mushrooms.

When mice were implanted with Sarcoma 180, the tumors were inhibited by more than 60% after one month. (Ying, 1987.) The Oyster mushrooms constituted 20% of their daily diet. Oyster mushrooms figure as a relatively minor player, comparatively, in the realm of medicinal mushrooms. Anecdotal reports suggest this mushroom improves liver and kidney function and helps gastrointestinal disorders. According to Singer (1986) the sclerotia of a related, tropical species, *Pleurotus tuber-regium* (Fr.) Singer is used by native peoples for such diverse medicinal purposes as stomach pain, constipation, fever, blood pressure and even smallpox.\* (Singer (1986) and Oso (1977)).

Allergic reactions to the spores of *P. ostreatus* are commonly reported by workers picking mushrooms indoors. Symptoms include fever, headache, congestion, coughing, sneezing, nausea, & general malaise. Workers who, at first, can tolerate contact with Oyster spores, often develop increased sensitivity with continued exposure. Filtration masks help but do not entirely solve this work-place related problem. The question as to whether or not spores of Oyster mushrooms can carry virus harmful to humans has not yet been satisfactorily answered. Few individuals are allergic to Oyster mushrooms after they have been cooked. For more information, consult Reshef et al. (1988).

**Flavor, Preparation & Cooking:** Stir-fry in a light oil at high heat until golden brown and then cooked with other condiments.

**Comments:** The Oyster mushrooms are the easiest to grow. Disadvantages of their cultivation are in their short shelf life post harvest and the health problems posed by the prolific spore load generated within the confines of the growing room.

Cold and warm weather strains of this mushroom are widely in use. The above-described temperatures for initiating *P. ostreatus* are based on cold weather strains. Strains evolving in warm geographical niches behave more in accordance with the parameters outlined for *Pleurotus pulmonarius*. (See page 321.)

*Pleurotus ostreatus* is an extraordinarily interesting mushroom from many viewpoints. Highly tolerant and responsive to carbon dioxide levels, Zadrazil (1974) noted that mycelial growth peaks at 280,000 ppm or 28% CO<sub>2</sub>. Unless CO<sub>2</sub> levels are reduced to less than 1000 ppm (.01%), noticeable

\* For information on the cultivation of *Pleurotus tuber-regium*, consult Okhuoya et al. (1988 & 1990) and Omoanghe (1992). See Figure 43.

## Growth Parameters

### Spawn Run:

Temperature: 75° F. (24° C.)  
 Relative Humidity: 85-95%  
 Duration: 12-21 days  
 CO<sub>2</sub>: 5000-20,000 ppm  
 Fresh Air Exchanges: 1 per hour  
 Light Requirements: n/a

### Primordia Formation:

Temperature: 50-60° F. (10-15.6° C.)  
 Relative Humidity: 95-100%  
 Duration: 3-5 days  
 CO<sub>2</sub>: < 1000 ppm  
 Fresh Air Exchanges: 4-8 per hour  
 Light Requirements: 1000-1500 (2000) lux.\*

### Fruitbody Development

Incubation Temperature: 60-70° F. (10-21° C.)  
 Relative Humidity: 85-90%  
 Duration: 4-7 days  
 CO<sub>2</sub>: < 1000 ppm  
 Fresh Air Exchanges: 4-8 per hour.  
 Light Requirements: 1000-1500 (2000) lux.

### Cropping Cycle:

3-4 crops, 7-14 days apart, over 45-55 days.

malformations of the fruitbodies occur: typically long stems and small caps. In fact, the cap-to-stem ratio is an accurate measurement of atmospheric carbon dioxide levels in the growing room and is used as a visual cue by Oyster cultivators for increasing air exchange.

This mushroom species is also super-sensitive to light levels. (See Eger (1980)). In low light, a

\* Eger et al. (1974) determined that *P. ostreatus* forms the most primordia in response to a light intensity of 2000 lux or about 185 foot candles. Light intensities exceeding 2000 lux/hour caused a precipitous drop in the number of primordia forming. At 10,000 lux/hr. (>925 foot candles), primordia failed to form. Their studies showed that continuous, optimal light stimulation during the primordia formation resulted in the largest population of primordia. (However, I note that if the base nutrition or the strain can not support the development of such large population of primordia, the cultivator may actually reduce yield efficiency.) Studies by Kalberer (1974) showed that total yield was maximized (and stem mass minimized) at 300-430 lux at 12 hours per day. The critical primordia formation period extends for 6-7 days. If the total light exposure, measured in "lux hours" per day fails to exceed 2400, equivalent to 100 ux or approx. 9 ft. candles of continuous lighting, *P. ostreatus* is triggered into "coral" formation. (See Figure 190). Continuous lighting at optimal levels prevent re-vegetation of developing primordia, a phenomenon occurring with many strains grown in under-exposed settings. Once primordia are well formed, diurnal cycles are recommended. As insightful as this research is, strain sensitivity could sway light optima in either direction.

similar effect to that seen under elevated carbon dioxide conditions is induced. When exposed to high light levels, pigmentation of the cap is usually enhanced. Blue strains become bluer. Brown capped strains become a richer brown. Similar results are also seen at lower end temperatures given constant light conditions.

Thorn and Barron (1984) first noted that *P. ostreatus* exudes a metabolite toxic to nematodes. As the nematode lies stunned, the mycelium soon invades through one of its orifices, quickly consuming the internal organs. From an evolutionary viewpoint, this is remarkable that a saprophytic mushroom can become predatory to an animal in its quest for new sources of nitrogen. This may well explain why nematodes have never been reported as a pathogen in Oyster mushroom cultivation whereas their occurrence in the cultivation of the Button mushroom (*Agaricus brunnescens*) is economically devastating and commonplace.

---

---



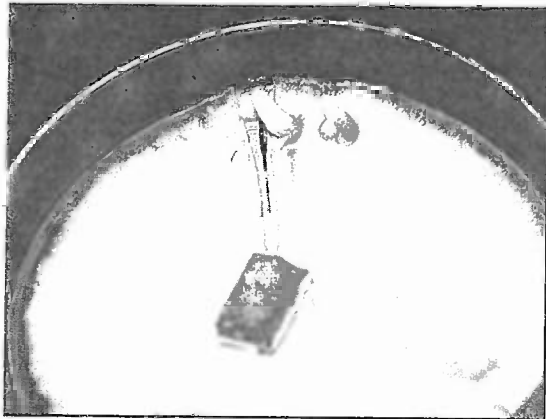
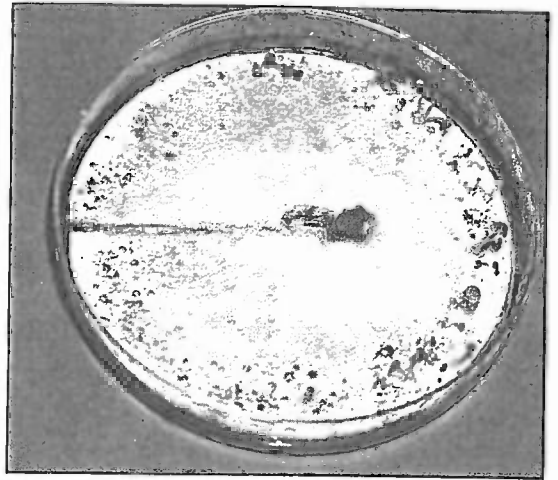
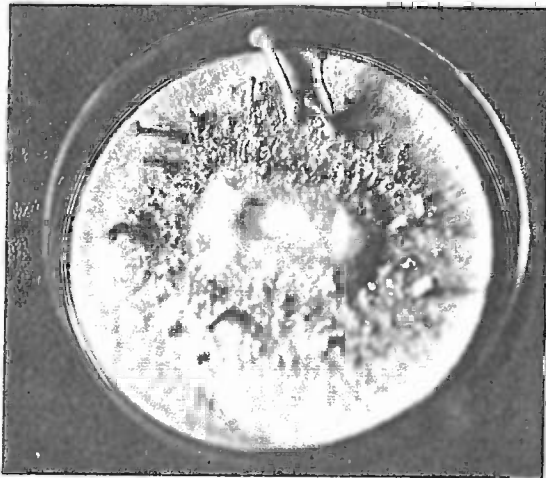
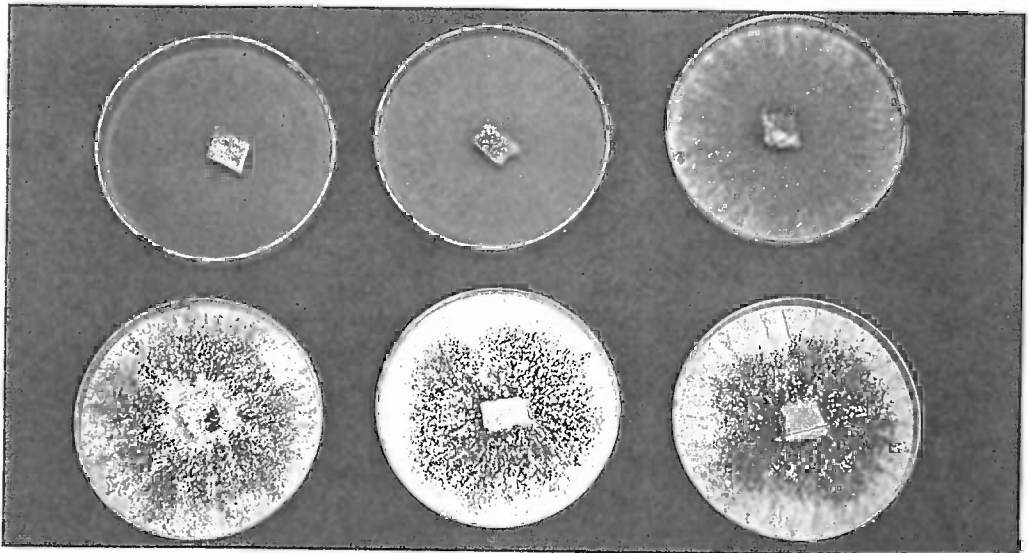

**Plate 1.** Fruiting culture of *Agrocybe aegerita*, the Black Poplar Mushroom.

**Plate 2.** Fruiting culture of *Flammulina velutipes*, Enokitake. (Top right.)

**Plate 3.** Fruiting culture of *Ganoderma lucidum*, Reishi or Ling Chi. (Middle left.)

**Plate 4.** Progressive development of the mycelium of *Morchella angusticeps*, the Black Morel.



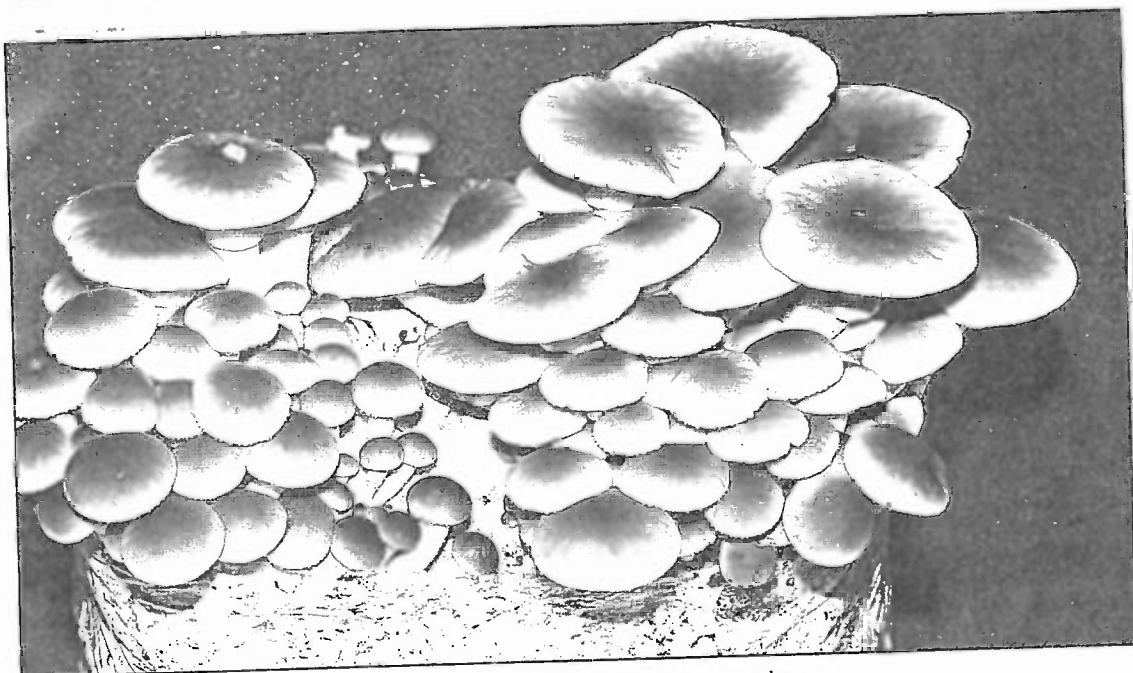
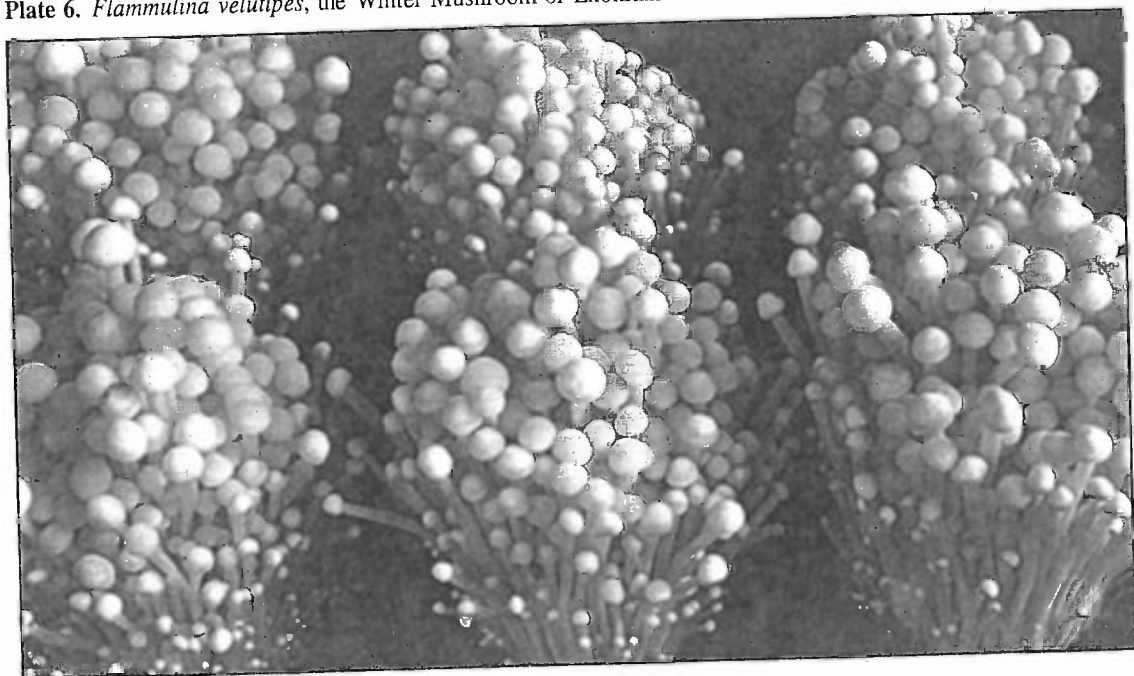

Plate 5. *Agrocybe aegerita*, the Black Poplar Mushroom or Yanagi-matsutake.

Plate 6. *Flammulina velutipes*, the Winter Mushroom or Enokitake.





**Plate 7.** *Flammulina velutipes*, the Enoki Mushroom, fruiting from bottles of supplemented sawdust.

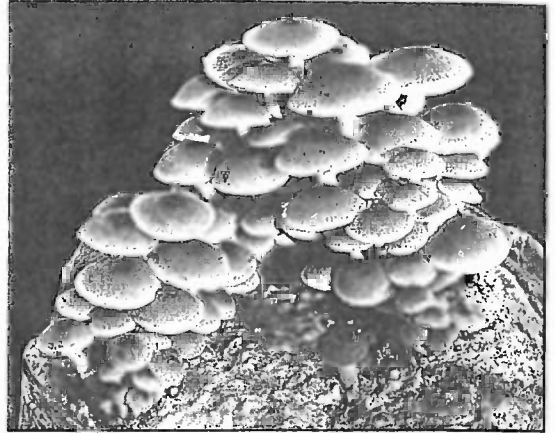

**Plate 8.** *Hypholoma sublateritium*, Brick Tops or Kuritake. (Top right.)

**Plate 9.** *Hypholoma sublateritium*, Kuritake, fruiting from partially buried logs. (Lower right.)

**Plate 10.** *Hypsizygus ulmarius*, the Elm Oyster Mushroom or Shirotamogitake.

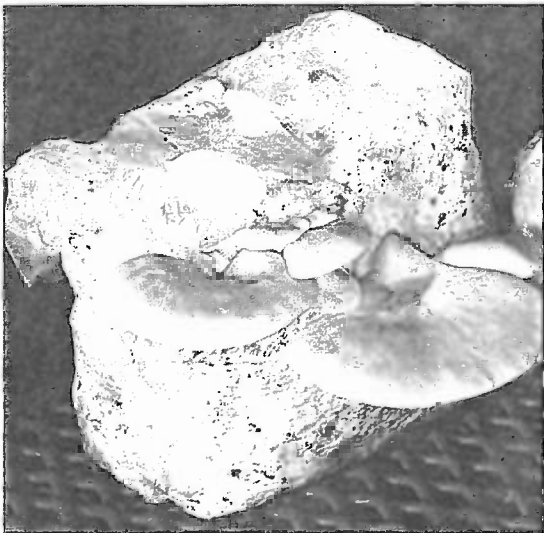

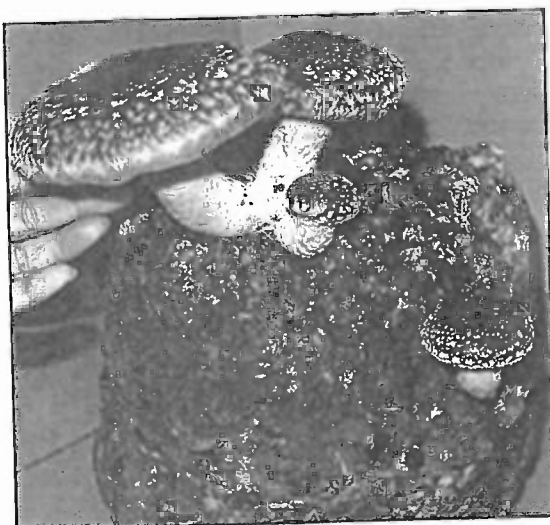
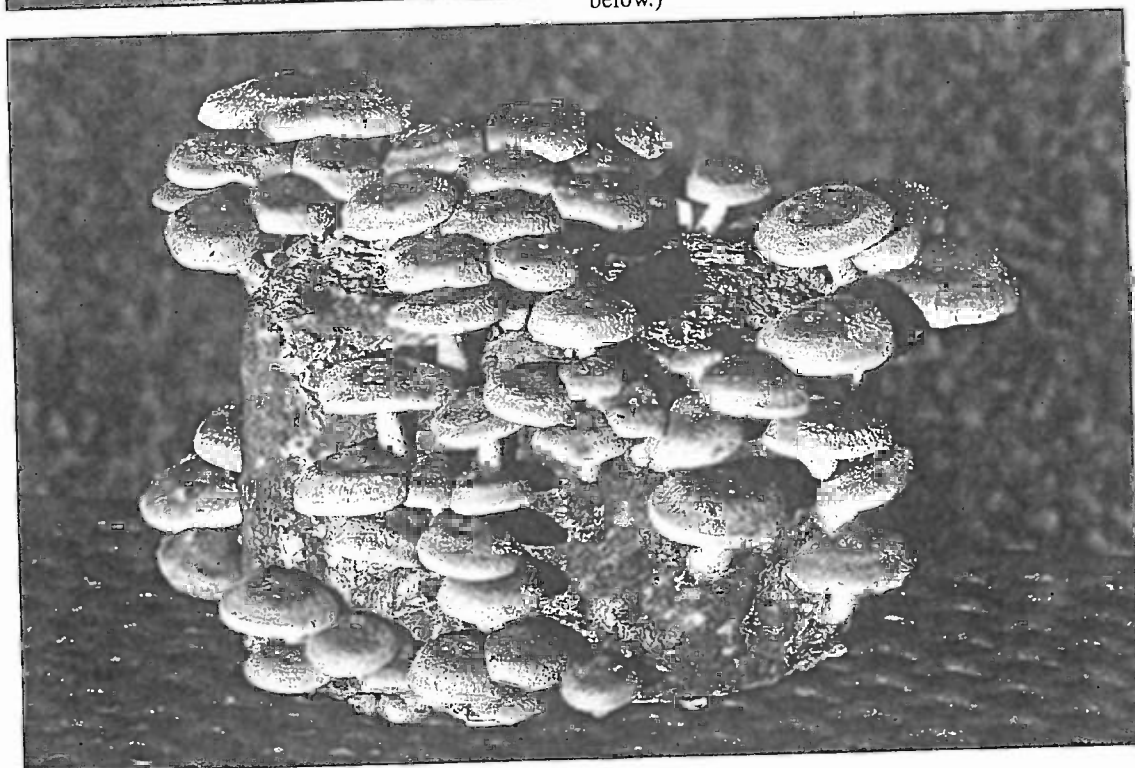
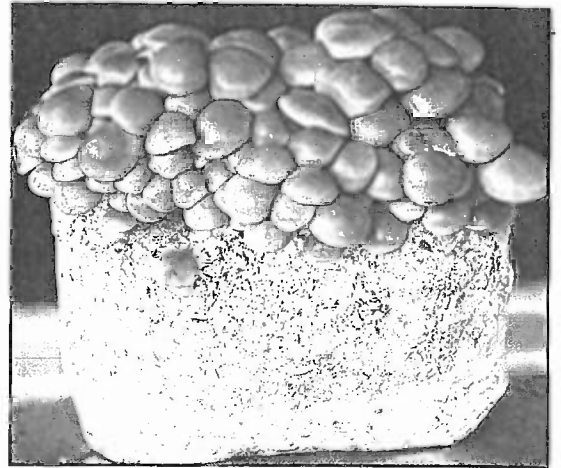

Plate 11. Azureus Stamets holding a 5 lb. block of supplemented sawdust producing a 1 lb. specimen of *Lentinula edodes*, the Shiitake mushroom. (Left.)

Plates 12 & 13. Shiitake mushrooms fruiting from blocks of supplemented, alder sawdust. (Above and below.)





**Plates 14.** Shiitake mushrooms, *Lentinula edodes*, fruiting from oak logs. (Top left.)

**Plate 15.** *Pholiota nameko*, the Nameko mushrooms, fruiting from supplemented alder sawdust. (Top right.)

**Plate 16.** *Pholiota nameko*, fruiting from maple and alder 'rounds' one year after inoculation. (Below.)





Plates 17-20. *Pleurotus citrinopileatus*, the Golden Oyster Mushroom, fruiting from columns of pasteurized wheat straw and from bottles of sterilized sawdust.

Plate 21. Trays of harvested Golden Oyster Mushrooms ready for market. (Right.)

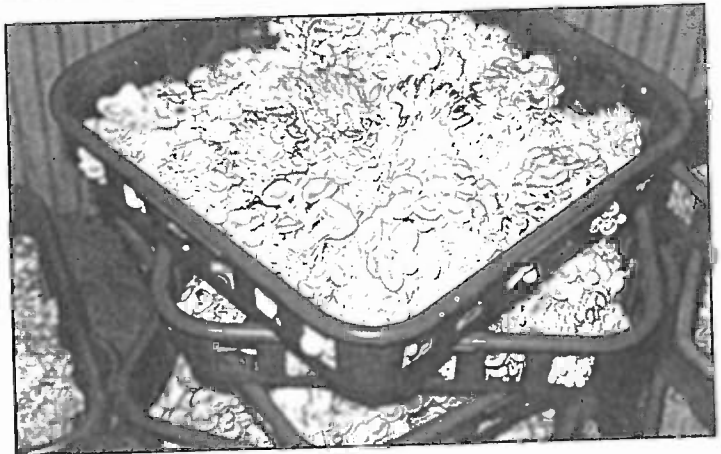



Plate 22. *Pleurotus eryngii*, the King Oyster Mushroom.



Plates 23-24. *Pleurotus djamor*, the Pink Oyster Mushroom, fruiting from pasteurized wheat straw.

Plate 25. The Pink Oyster Mushroom and its albino form.





Plate 26. The type collection of *Psilocybe cyanofibrillosa* fruiting wildly from Douglas fir sawdust.

Plate 27. *Psilocybe azurescens* nom. prov. cultivated outdoors in hardwood chips.







Plate 28. *Psilocybe azurescens* nom. prov. ready for harvest.

Plates 29 & 30. Sacred mushroom patches of *Psilocybe cyanescens* sensu lato, sometimes called Fantasi-takes, cultivated outdoors.





Plate 31. LaDena Stamets with 5 lb. specimens of *Stropharia rugoso-annulata*, the King Stropharia or Garden Giant Mushroom.

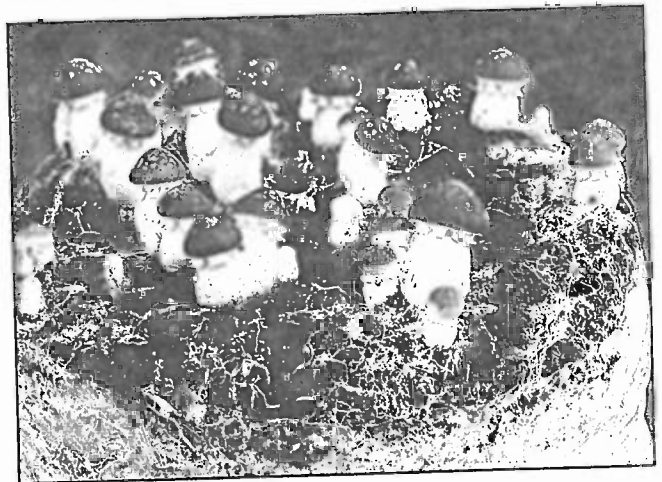

Plate 32. Typical fruiting.

Plate 33. Young buttons of King Stropharia fruiting from cased, pasteurized wheat straw.

Plate 34. LaDena Stamets with King Stropharia at ideal stage for consumption.

Plate 35. 2 lb. specimen of King Stropharia.



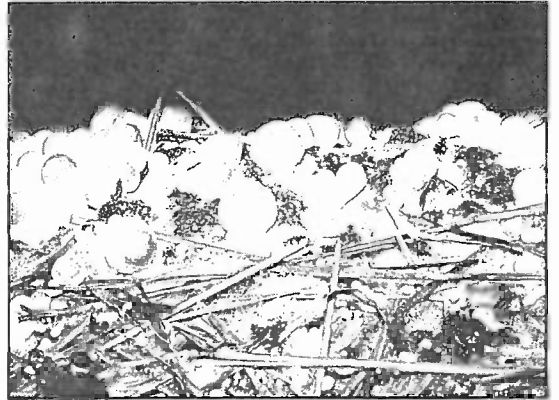
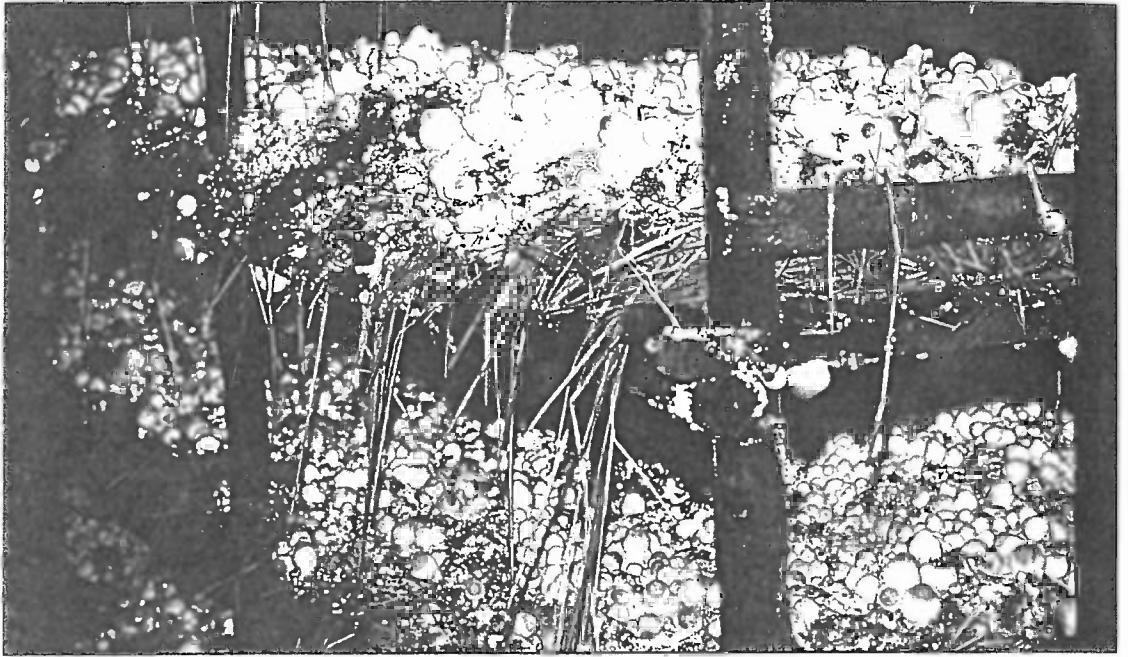

Plates 36-38. Fruittings of *Volvariella volvacea*, the Paddy Straw Mushroom, from rice straw.

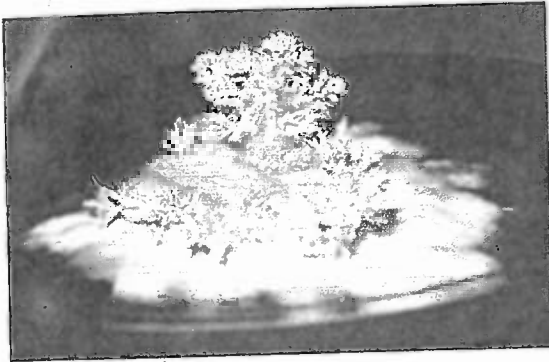
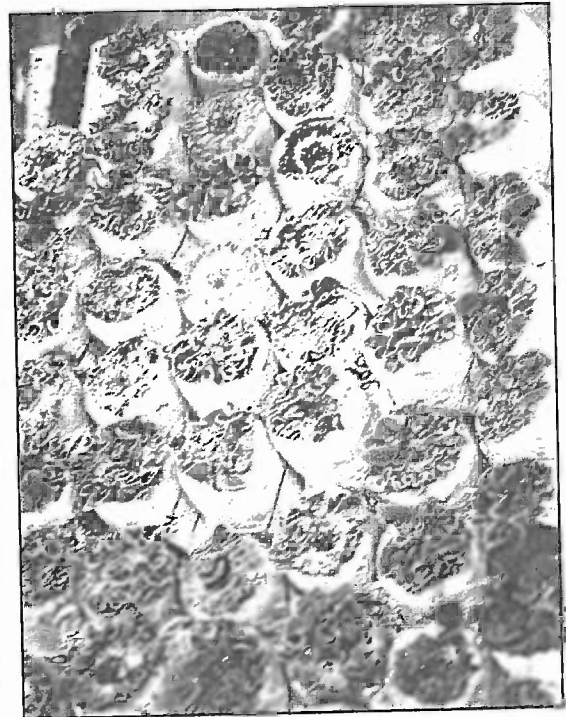
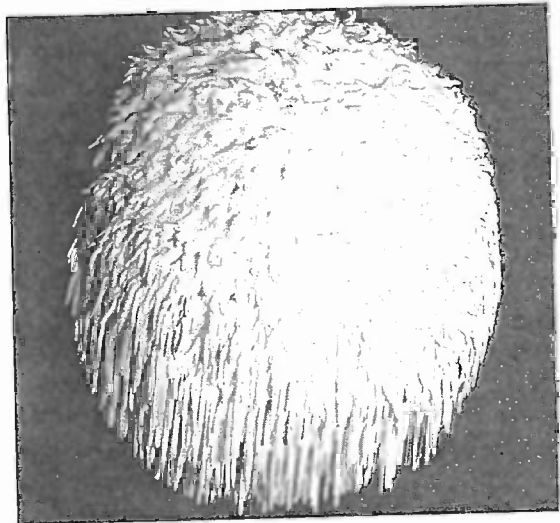

Plate 39. *Hericium erinaceus*, Lion's Mane, fruiting from malt extract agar.

Plates 40 & 41. Classic Lion's Mane fruitbodies.

Plates 42 & 43. *Auricularia polytricha*, the Wood Ear or Kikurage, fruiting from sterilized sawdust.



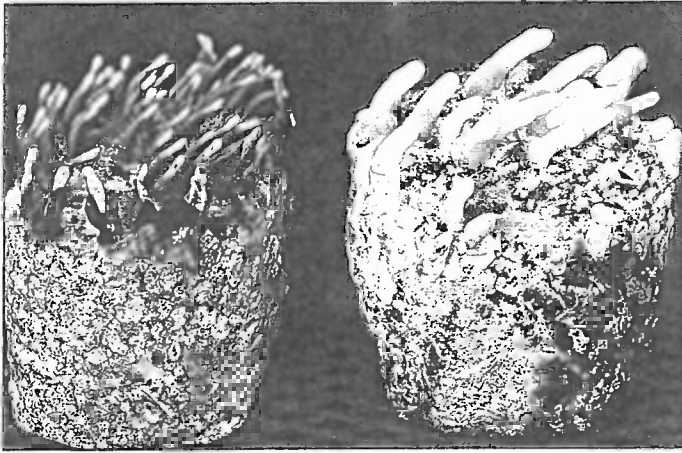

Plate 44. Two strains of *Ganoderma lucidum*, Reishi or Ling Chi, growing towards light.

Plate 45. Reishi wall constructed from stacked bags.

Plate 46. Reishi fruiting from inoculated logs.

Plate 47. Reishi fruiting from pots containing inoculated logs topped with soil.



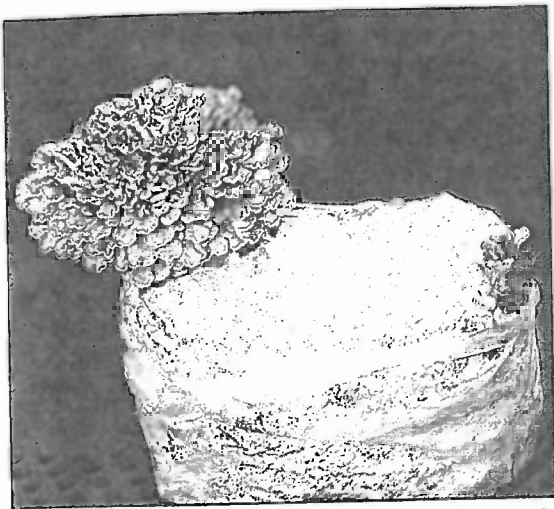

Figures 48 & 49. 3/4 lb. and 1 lb. clusters of *Grifola frondosa*, Maitake or Hen-of-the-Woods, fruiting from blocks of supplemented alder sawdust.

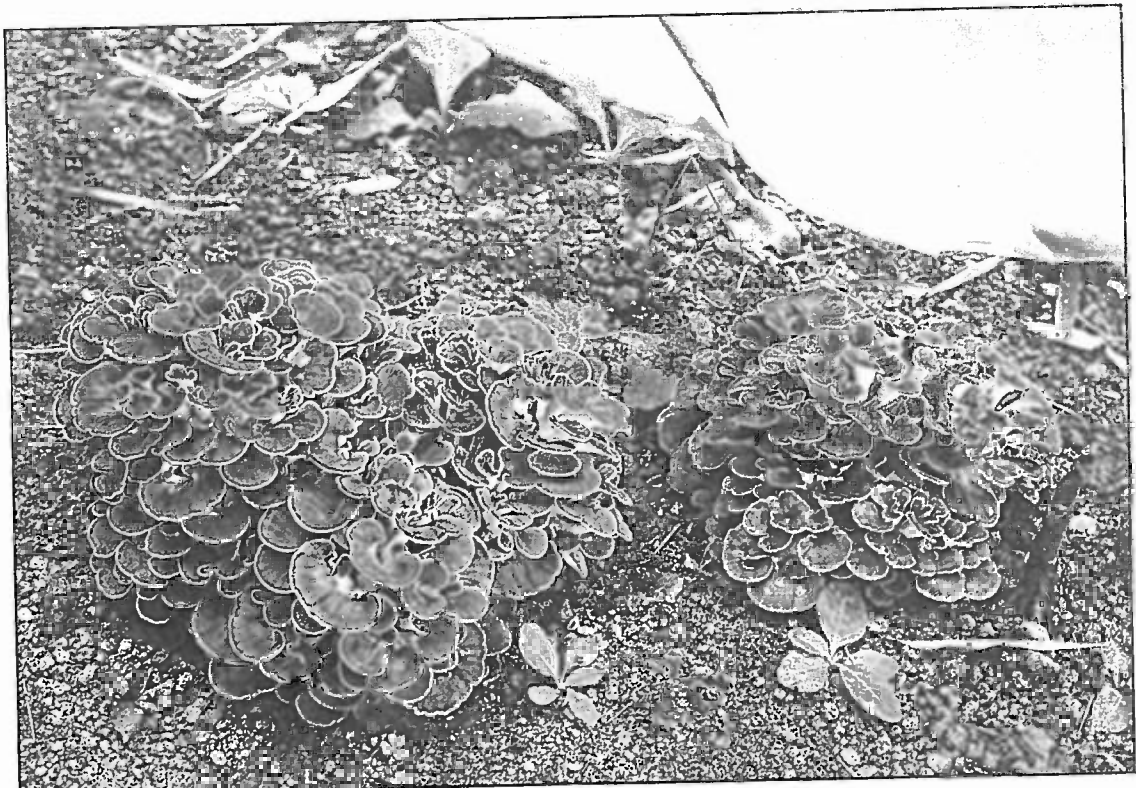

Plate 50. Outdoor fruitings of Maitake arising from blocks buried into soil.



Plate 51. Succulent bouquet of Maitake ready for consumption.

Plate 52. Mycologist Bill Chapman holding giant, wild Maitake.

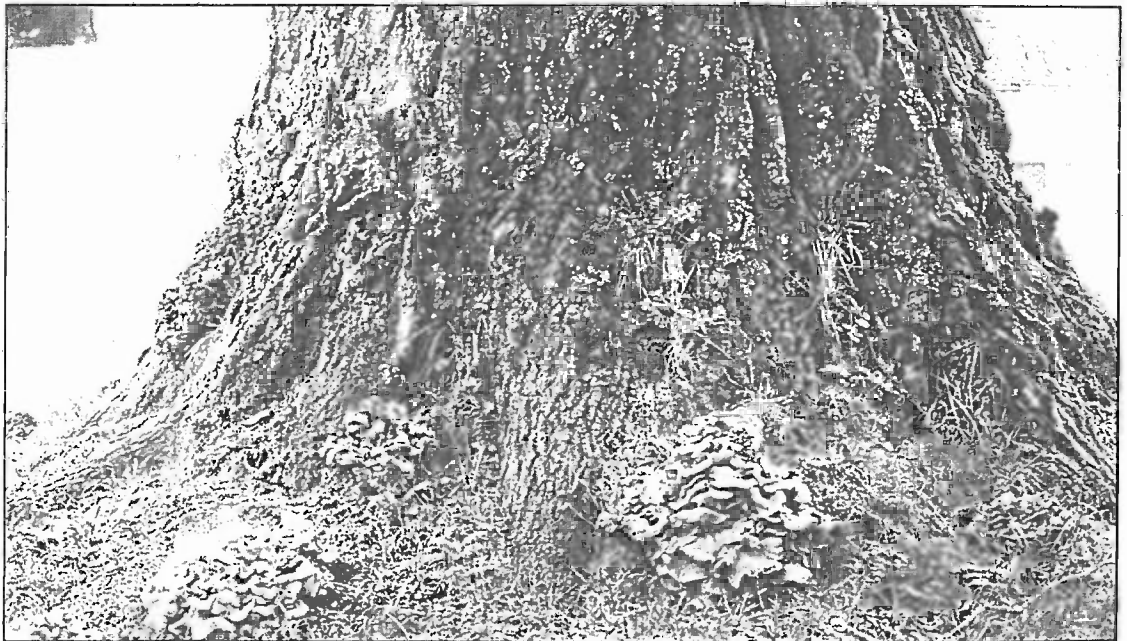
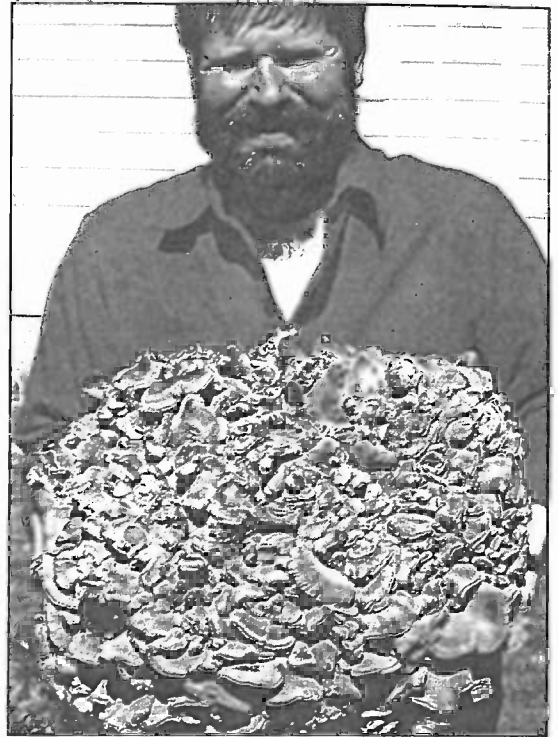
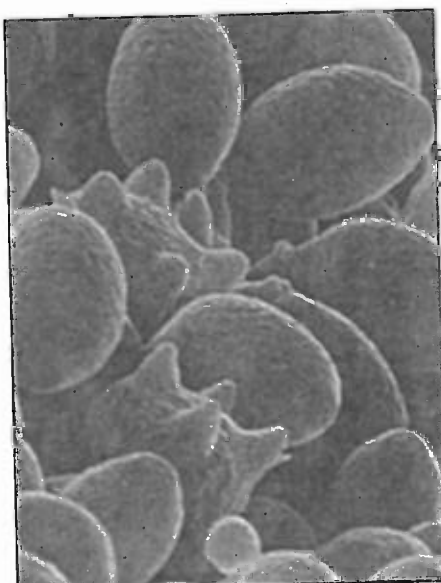
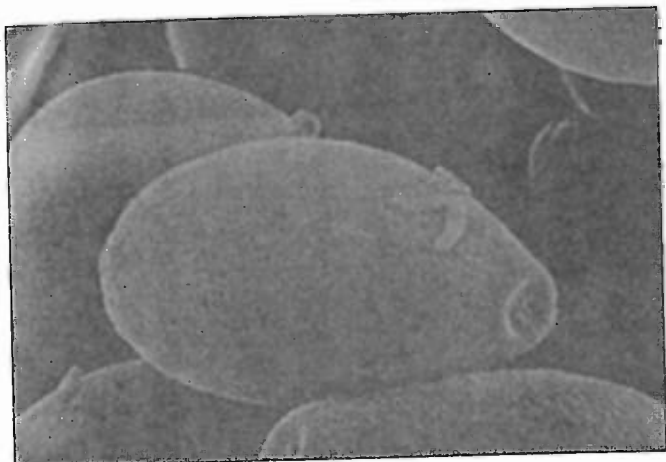

Plate 53. Wild fruitings of Maitake from a stately oak tree in a colonial graveyard in upstate New York.

---

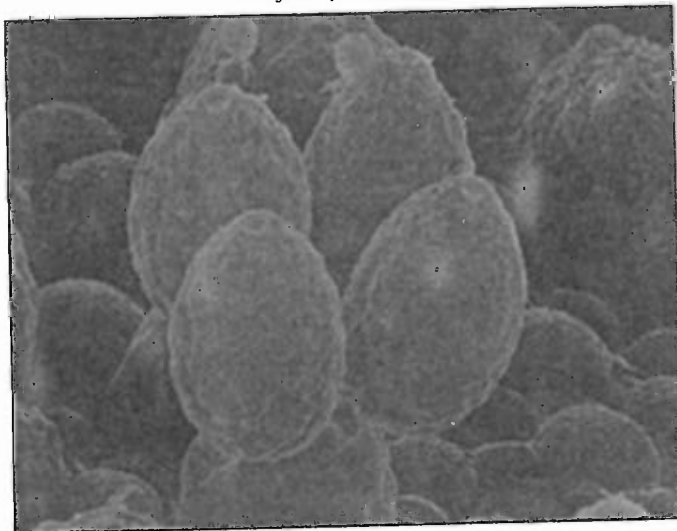
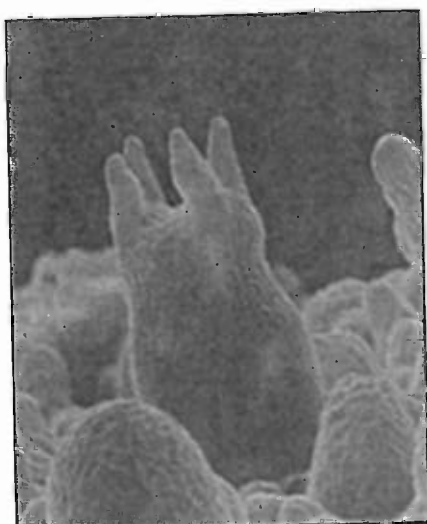
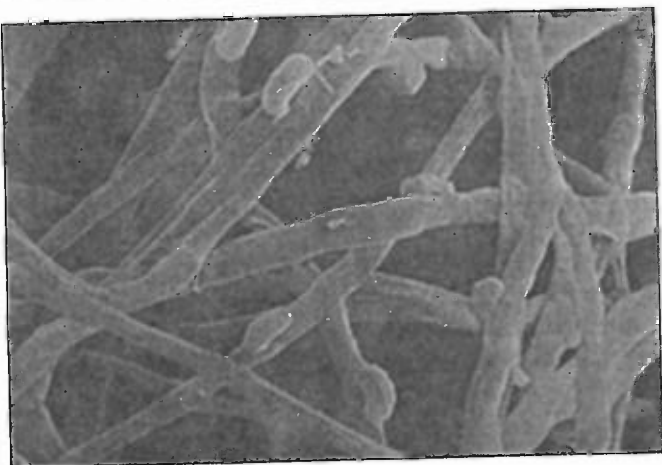

**Plate 54.** Scanning Electron Micrograph (S.E.M.) of mushroom spore contaminated with bacteria. (Top left.)

**Plate 55.** S.E.M. of mycelium with clamp connections. (Middle left.)

**Plates 56 & 57.** S.E.M. of emerging basidia. (Top right & lower left.)

**Plate 58.** S.E.M. of mature basidium about to eject spores. (Lower right.)





*Pleurotus pulmonarius* (Fries) Quelet

Figure 286. Culture of *P. pulmonarius* 3 and 5 days after inoculation onto sterilized malt extract agar media.

**Introduction:** According to studies recently published by Vilgalys et al. (1993), *Pleurotus pulmonarius* is virtually indistinguishable from *P. ostreatus*, and differs largely in its habitat preference for conifer woods. In the Western United States, *P. pulmonarius* is usually found at higher altitudes than *P. ostreatus* which prefers the lowland, river valleys. *P. pulmonarius* and *P. ostreatus* grow on a variety of hardwoods, with *P. pulmonarius* primarily a spring mushroom and *P. ostreatus* growing most prevalently in the summer to fall. The North American collections, show a wider range in color than the European collections. *P. pulmonarius* hosts a large complex of varieties, offering cultivators a rich resource for new strains. Most of these strains fruit in culture.

**Common Names:** The Indian Oyster  
The Phoenix Mushroom  
Dhingri (in northern India)  
“*Pleurotus sajor-caju*” (mis-applied by cultivators)

**Taxonomic Synonyms & Considerations:** This mushroom was first published as *Agaricus pulmonarius* Fr. in 1821. Similar to *P. ostreatus* (Jacq.:Fr.) Kummer and *P. populinus* Hilber & Miller, this species can be separated from them by a combination of habitat, macroscopic, and microscopic features. *P. pulmonarius* and *P. populinus* both share a preference for aspen and black poplar. *P.*

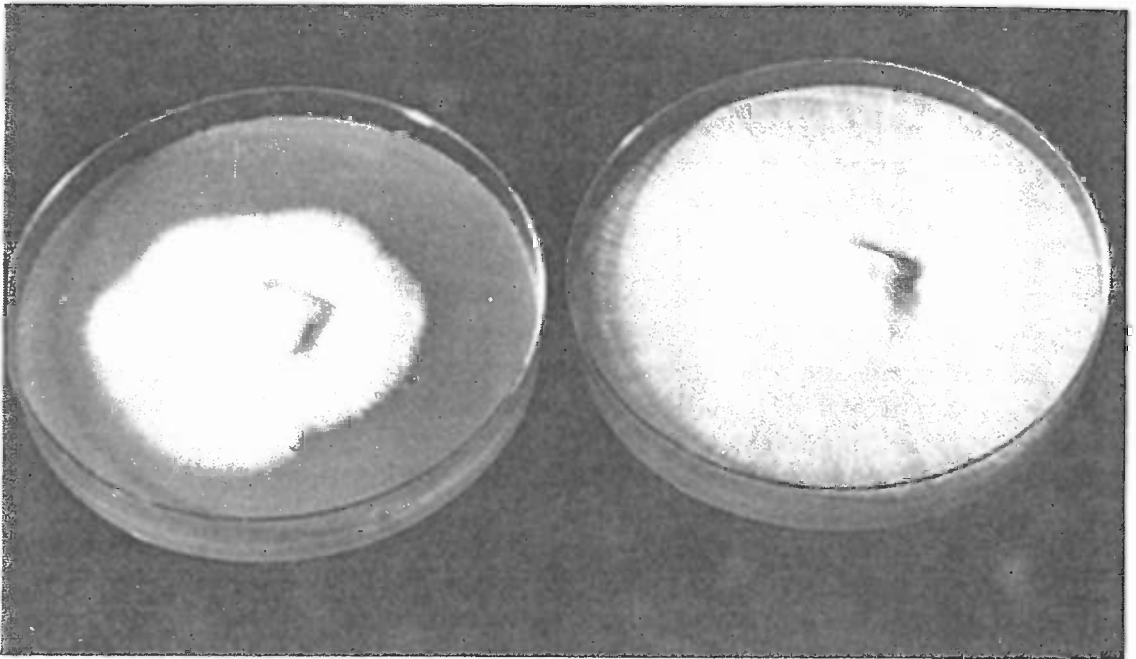
*pulmonarius* is usually more darkly pigmented and has spores generally not longer than  $10\mu$  long compared to the paler *P. populinus* whose spores often measure up to  $15\mu$  in length.

Cultivator-mycologists have mistakenly called a variety of this mushroom "*Pleurotus sajor-caju*". The true *Pleurotus sajor-caju* (Fr.) Singer has been returned to the Genus *Lentinus* by Pegler (1975), and is now called *Lentinus sajor-caju* (Fr.) Fries. *Pleurotus sajor-caju* (Fr.) Sing. has a distinct veil, a persistent ring on the stem, and trimitic or dimitic hyphae composing the flesh. (*P. pulmonarius* is monomitic.) In light of this new information, Singer's remark in *The Agaricales in Modern Taxonomy* (1986, p. 178) concerning the similarity of *P. sajor-caju* and the likelihood of its sharing synonymy with *Lentinus dactylophorus* and *Lentinus leucochrous* is now understandable. He was describing a mushroom completely different than the one cultivators grow in United States and Europe and have been calling "*P. sajor-caju*".

The name "*P. sajor-caju*" has been mis-applied so frequently that confusion will likely reign for a considerable time. Many of the scientific papers published on the extraordinary yields of "*P. sajor-caju*" on straw, cotton wastes, coffee residues (ad infinitum) are undoubtedly referring to a strain of *P. pulmonarius*. (See Hilber (1989), p. 246). Since the name has become so entrenched by cultivators, naming a new variety, i.e. *Pleurotus pulmonarius* var. *sajor-caju* seems like a good compromise. Until then, cultivators should refrain from calling this commercially cultivated Oyster mushroom "*Pleurotus sajor-caju*", as it is incorrect.

**Description:** Cap convex at first, expanding to broadly convex, eventually flat or upturned and often wavy in age. 5-20 cm (+) in diameter. Grayish white to beige to lilac grey to grey-brown, sometimes with pinkish or orangish tones. (At high temperatures, the cap is lighter in color. Under the same light conditions, under cold conditions, the cap becomes very dark gray to grayish black.) Cap margin smooth to undulating like an Oyster. Color varies according to the strain, lighting, and temperature conditions. Stems are typically eccentrically attached to the cap. Veil absent. Flesh generally thin. Strains of this mushroom rarely form clusters of more than 5 or 6 mushrooms.

**Distribution:** Widely reported from North America and Europe.

**Natural Habitat:** In the eastern United States, this mushroom primarily decomposes hardwoods while in the western regions, the species can be found at middle elevations (1200-3000 meters) on conifers (*Abies* and *Picea*). Common in the spring and summer.

**Microscopic Features:** Spores white to yellowish to lavender grey when dense, more or less cylindrical,  $7.5-11 \times 3-4\mu$ . Clamp connections present. Hyphal system monomitic.

**Available Strains:** Plentiful, available from most all culture libraries, and frequently mis-labelled as "*Pleurotus sajor-caju*". A nearly sporeless strain, known as "3300 INRA-Somycel", produces about 1/100th of the spore load of normal strains, but is less productive. (See Imbernon & Houdeau, 1991). The development for high yielding, low sporulating strains of *Pleurotus* is essential to limit the impact spores have on the health of workers.

**Mycelial Characteristics:** White, linear, becoming cottony, and eventually forming a thick, peelable, mycelial mat. If cultures on agar media or on grain are not transferred in a timely fashion (i.e.

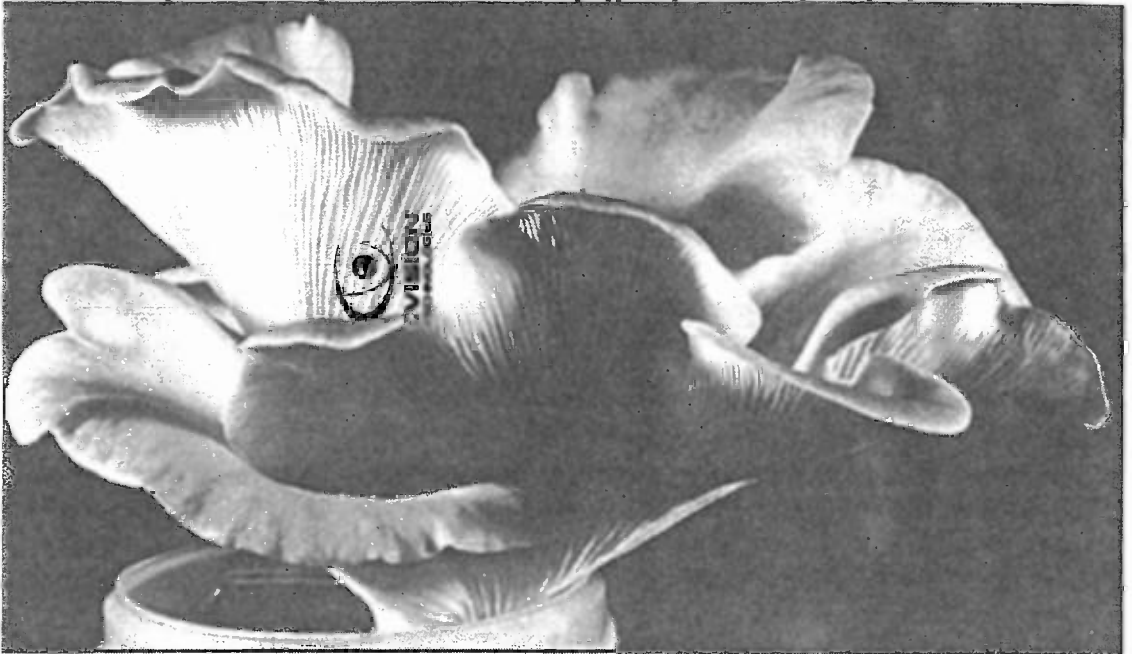

Figure 287. *P. pulmonarius* fruiting from jar of sterilized sawdust.

within two weeks), the mycelium becomes so dense as to make inoculations cumbersome and messy. Over-incubated cultures can not be cut, even with the sharpest, surgical grade scalpel, but are torn from the surface of the agar media.

**Fragrance Signature:** Grain spawn sweet, pleasant, and distinctly “Oyster-esque”.

**Natural Method of Cultivation:** When the first log with fruiting Oyster mushrooms was brought from the forest into the camp of humans, probably during the paleolithic epoch, Oyster mushroom cultivation began. This mushroom is *exceedingly easy* to cultivate and is especially aggressive on alder, cottonwood, poplar, oak, maple, elm, aspen and some conifers. Other materials used for natural culture include wheat, rice or cotton straw, corn cobs and sugar cane bagasse.

Since this mushroom grows wild on conifers (*Abies* (firs) & *Picea* (spruce)), cultivators would be wise to develop strains that could help recycle the millions of acres of stumps that characterize the western forests of North America, if not the world.

**Recommended Courses for Expansion of Mycelial Mass to Achieve Fruiting:** Liquid inoculated grain spawn sown directly into pasteurized straw or sterilized sawdust. This mushroom is more economically grown on pasteurized substrates, especially the cereal straws, than on wood-based substrates.

**Suggested Agar Culture Media:** MYPA, PDYA, OMYA and/or DFA.

**1st, 2nd & 3rd Generation Spawn Media:** Grain spawn throughout.

**Substrates for Fruiting:** Broadly adaptive, producing mushrooms on a great array of organic debris. The substrate materials proven to result in the greatest yields are the cereal (wheat, rice) straws, hardwood sawdusts, corn stalks, sugar cane bagasse, coffee waste (Martinez et al., 1985), pulp mill sludge (Mueller & Gawley, 1983), cotton waste and numerous other agricultural and forest waste by-products. Royse & Bahler (1988) found that the addition of 20% alfalfa hay to wheat straw increased yields substantially. In their studies, yields peaked when a combination of wheat straw, alfalfa, and delayed release nutrients were employed. (The effect of delayed release nutrients on Oyster mushroom yield is discussed in detail by Royse & Schisler, 1987a, 1987b.) Alfalfa hay, as any compost maker knows, is considered "hot" because of its elevated nitrogen component. Although yields can be boosted by adding these nitrogenous supplements, the cultivator must balance whether or not this advantage is offset by the likely increase in contamination rates. (As a rule, the likelihood of competitor molds increases directly as nitrogen levels are elevated.) For more information, consult Zadrazil (1980).

**Recommended Containers for Fruiting:** Perforated plastic bags, columns, bags, trays, vertical racks, and bottles.

**Yield Potentials:** Biological efficiency 100-200%, greatly affected by the size of the fruitbody at the time of harvest and whether or not a fourth or fifth flush is achieved.

**Harvest Hints:** Because this mushroom grows so quickly, the timing of harvest is critical to the quality of the overall crop. Mushrooms more often form individually, in twos or threes, but rarely more. New mushrooms often form where the old mushrooms have been cut, a trait not generally seen with other *Pleurotus* species. If the mushrooms are picked at full maturity, they are quick to rot, especially if kept within a container where gas exchange is limited. Under these conditions, bacteria proliferate, and hundreds of primordia form directly on the rotting fruitbodies. See Figure 380.

**Form of Product Sold to Market:** Mostly fresh. Some products, especially soup mixes, feature dried, powdered mushrooms.

**Nutritional Content:** Crude Protein (N x 4.38): 14-27%; fat:2%;

carbohydrates: 51% (on a dry weight basis). The variation in the reported protein composition of *P. pulmonarius* and its close relatives is discussed by Rai et al. (1988). For additional information on the



Figure 288. *P. pulmonarius* fruiting from 25 lb. bag of wheat straw.

---

## Growth Parameters

### Spawn Run:

Incubation Temperature: 75-85° F. (24-29° C.)

Relative Humidity: 90-100%

Duration: 8 -14 days

CO<sub>2</sub>: > 5000 ppm

Fresh Air Exchanges: 1 per hour.

Light Requirements: n/a.

### Primordia Formation:

Initiation Temperature: 50-75° (80°) F. (10-24° (27°) C.)

Relative Humidity: 95-100% rH

Duration: 3-5 days

CO<sub>2</sub>: 400-800 ppm.

Fresh Air Exchanges: 5-7 per hour

Light Requirements: 1000-1500 (2000) lux.

### Fruitbody Development:

Temperature: 60-80° F. (18-27° C.)

Relative Humidity: 85-90% (95%) F.

Duration: 3-5 days.

CO<sub>2</sub>: 400-800 ppm

Fresh Air Exchanges: 5-7 per hour.

Light Requirements: 1000-1500 (2000) lux.

### Cropping Cycle:

Every 7-10 days for 3 flushes.

---

nutritional aspects of this mushroom (identified as “*P. sajor-caju*”), see Bano & Rajarathnam (1982) and El-Kattan et al., (1991). At 25% protein, this mushroom has about 1/2 of the protein represented in a hen’s egg, and about 1/3 of most meats.

**Medicinal Properties:** Not known.

**Flavor, Preparation & Cooking:** *P. pulmonarius* enhances any meal featuring fish, lamb, and pork. Of course, it also is excellent with most vegetarian cuisines. Slicing and/or chopping the mushrooms and adding them into a stir fry is the most popular method of preparation. Young mushrooms are far superior to adult specimens, in texture and flavor.

**Comments:** This species complex hosts an enormous number of strains. The most popular are the warm weather varieties currently being marketed by spawn manufacturers, often under the name “*Pleurotus sajor-caju*.” This mushroom is more widely cultivated than any other Oyster mushroom in North America and Europe.

---

Tolerant of high temperatures, renowned for its speed to fruiting and yield efficiencies, many cultivators are initially attracted to this mushroom. However, compared to the other Oyster-like species mentioned in this book, I hesitate to call it a “gourmet” mushroom. Although high yielding, I do not hold it in high regard for numerous reasons, such as its

- continued growth after harvest.
- lack of cluster-bouquet formation.
- premature fruiting.
- quickness to spoil.
- production of high spore loads.
- attractiveness to fungus flies.

These may be merely the complaints of a critical connoisseur. Many people use and like this species. *P. pulmonarius* remains the favorite of many of the largest Oyster growers in the world, especially those located in warmer climatic zones.

Okwujiako (1990) found that the vitamin thiamine was critical for growth and fruitbody development in *P. pulmonarius*. By simply adding yeast extract to the base medium, vitamins essential for enhanced fruitbody production are provided. For more information on the cultivation of *P. pulmonarius* refer to Bano & Raharathnam (1991) and Azizi et alia (1990). (Please note that these authors describe *Pleurotus sajor-caju* when, in fact, they were probably cultivating a variety *P. pulmonarius*.)

For more information, consult Vilgalys et al. (1993), Hilber (1982), Kay & Vilgalys (1992), and Petersen & Hughes (1992).

---

## The Caramel Capped *Psilocybes* (Pacific Coast *Teonanacatls*: Mushrooms of the Gods)\* of the Genus *Psilocybe*

For millennia, *Psilocybes* have been used for spiritual and medicinal purposes. Curanderos—Meso-American shamans—relied upon them to diagnose illness and to prognosticate the future. Through the works of R. Gordon Wasson, Jonathan Ott, Andrew Weil, Terence McKenna and others, these mushrooms became well known to North Americans. In the mid 1970's, a group of dedicated mycophiles from the Pacific Northwest of North America pioneered the outdoor domestication of the temperate, wood-loving *Psilocybe* species. From these species, many imaginative cultivators learned techniques applicable to the cultivation of many other woodland gourmet and medicinal mushrooms. Since I have studied this group for many years and since this constellation of species has become the template for natural culture in North America, it seems fitting that this species complex be explored further.



Figure 289. *P. cyanescens* complex fruiting on alder wood chips overlaid with a thin layer of straw.

\* The Genus *Psilocybe* as monographed by Guzman (1983) has species which contain indole alkaloids (psilocybin, psilocin) that are known to be "psychoactive". Many species in the Genus *Psilocybe* do not possess these pharmacologically active compounds. However, in addition, a number of mushroom species unrelated to *Psilocybe* also contain these indoles. This section is offered for its academic value and does not encourage the violation of any ordinances restricting the possession or propagation of any illegal substance. Readers should further note that some individuals react negatively from the ingestion of psilocybian mushrooms. The author's research on this group was conducted under the provisions of a Drug Enforcement Administration license.

*Psilocybe cyanescens* Wakefield sensu lato

**Introduction:** First cultivated in Washington and Oregon in the late 1970's, this complex of species is primarily grown outdoors in wood chip beds. Indoor cultivation is possible but pales in comparison to natural culture methods. Species in the *P. cyanescens* complex are not as high yielding per lb. of substrate as some of the fleshier mushrooms in the genus and hence have little or no commercial appeal. However, these mushrooms enjoy a popular reputation and are sought by thousands of eager hunters every fall. Because they are infrequently encountered in the wild, many mycophiles create a mushroom patch in the privacy of their backyards.

**Common Names:** Cyans  
Caramel Caps  
Blue Angels  
Potent Psilocybe  
Fantasi-takes

**Taxonomic Synonyms & Considerations:**

The name *Psilocybe* is Greek and means "bald head" which refers to the smooth surface texture of the cap. The Genus *Psilocybe* has such close affinities to *Stropharia* and *Hypholoma* that separation of these genera continues to present unique taxonomic difficulties. These genera are clustered within the family Strophariaceae, which also includes the more distantly related Genus *Pholiota*. Alexander Smith (1979) proposed that the family might best be represented by only two genera: the Genus *Pholiota* and the Macro-genus *Psilocybe* which would also envelope species of *Stropharia* and *Hypholoma* (as *Naematoloma*).

Currently, the most thorough treatment of the genus can be found in Gaston Guzman's *The Genus Psilocybe: A World Monograph* (1983). This extensive monograph contains much original research and updates more than two decades of data accumulated by Roger Heim & R. Gordon Wasson and other researchers. Wasson & Heim's beautifully illustrated monograph *Les Champignons Hallucinogenes du Mexique* (1958) revealed new MesoAmerican species, many of which were pre-empted by the nearly simultaneous publication of Singer & Smith's update on *Psilocybe* (1958) which listed several novel species and sections.\* This event set the stage for a heated debate on

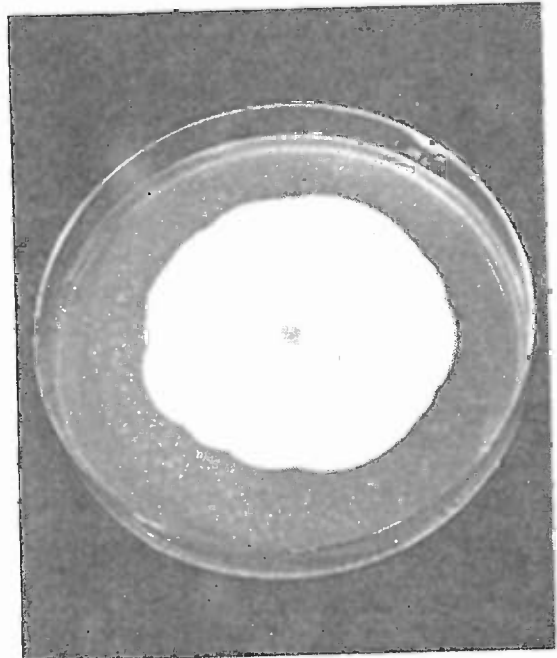

Figure 290. The satin-like mycelium of *Psilocybe azurescens* nom. prov., a sister species to *P. cyanescens*, growing on malt extract agar.

\* According to the International Rules of Nomenclature, names are prioritized according to the date of publication. The first author to publish a description in latin and deposit specimens into an *internationally recognized and accessible herbarium* is granted first right of use. All subsequently published names are considered synonyms.



---

*Psilocybe* which persisted for years. (Consult Smith (1977), Ott (1978) and Singer (1986, pp. 570-571, see footnotes.))

Our limited understanding of the temperate, wood-inhabiting *Psilocybe*, particularly the *Psilocybe cyanescens* group, derives from, or more accurately suffers from, our interpretations of Singer and Smith's publications of 1958. We now know that a large constellation of species, subspecies and races revolves around the species concept of *P. cyanescens*. (The taxonomy of this group is mired in a problem comparable to *Pleurotus sajor-caju* and *Pleurotus pulmonarius*. (See page 321.)) Mycologists in the past have improperly mis-applied species concepts from the European continent to North American candidates.

The type collection of *Psilocybe cyanescens* described by Wakefield from England lacks pleurocystidia, microscopic sterile cells on the surfaces of the gills. The photographs of a mushroom species from western North America identified in popular field guides as *Psilocybe cyanescens* (see Stamets (1978), Arora (1979), Lincoff (1981), Arora (1991) and numerous papers published since 1958) show a mushroom which, in fact, possesses abundant, capitate pleurocystidia. (See Figure 291.) Since this feature is consistent and obvious in water mounts under a microscope, and occurs in such high numbers, the mushroom in question can not be the true *P. cyanescens*. In fact, I believe no species concept has yet been published to accurately delimit this mushroom.

Another unnamed species, originating from the Columbia river basin near Astoria, Oregon is similar to the misnamed "*P. cyanescens*". This mushroom, distinguished by its comparatively great size and non-undulating cap margin, is a close cousin, possibly belonging to the European *Psilocybe serbica* Moser et Horak complex. Provisionally, I am giving this mushroom the name *Psilocybe azurescens* Stamets and Gartz nom. prov. The third species in this group from the Pacific Northwest is distinguished by its forking cheilocystidia, and is called *Psilocybe cyanofibrillosa* Stamets & Guzman. (See Stamets et al., 1980) I know of several more taxa yet to be published. Despite the unusual attention these mushrooms have received, the taxonomy of this group needs further exploration. This group of new *Psilocybes* falls within an expanded concept of Singer & Smith's *Stirps Cyanescens* as amended by Guzman.

This complex of species is fairly easy to identify. The mushrooms are generally cosmopolitan, and virtually absent from virgin forest ecosystems. They thrive in sawdust and chips from alder and Douglas firs. The mushrooms are collybioid—forming clusters that resemble the Genus *Collybia* in habit only. The caps are uniquely caramel to chestnut colored and strongly hygrophanous. The cap is featured with a separable gelatinous skin and brown gills which produce purple brown spores. The base of the stems radiate clusters of thick white rhizomorphs. Upon bruising, the flesh turns bluish to dark purple. These features separate this group of mushrooms from all others. This group can be further delimited into two sub-groups: those possessing or lacking pleurocystidia. Species having pleurocystida can be lageniform or fusoid-ventricose with a narrow or bulbous apex.

**Description:** Caps are hemispheric at first, soon convex, expanding to broadly convex and eventually plane in age, 2-10 cm. in diameter. Caps are strongly hygrophanous, sometimes chestnut especially when old or when the gills have fully matured. Cap margins are typically even at first, and straightening with age. Some varieties develop a pronounced, distinct and undulating margin. Other species in

---

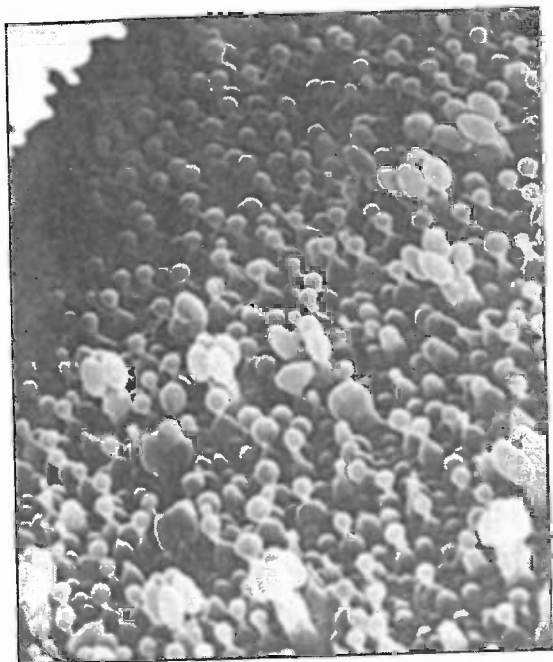

Figure 291. The abundance of capitate pleurocystidia precludes this species from being called "*P. cyanescens*". (Stamets Collection # 78-34).

this group have even margins. Gills are colored brown to dark brown, often mottled, and bluntly attached to the stem, typically with a thin whitish margin. The stem is centrally attached to the cap, silky white to dingy brown near the base, often covered with fine fibrils which may or may not bruise bluish. The stems are cartilaginous, even, straight to sinuous, usually swelling and curved towards the base. The base of the stem is usually fitted with a thick, radiating array of white rhizomorphs. Although mushrooms can be found individually, the majority grow in gregarious or collyboid clusters.

**Distribution:** The species represented in this group of mushrooms are found throughout the temperate forests of the world, including but not limited to the coastal Pacific Northwest of North America, northeastern North America, the British Isles, eastern Europe, southern Argentina, North Africa, New Zealand and temperate regions of Australia.

**Natural Habitat:** Heliotropic and primarily preferring deciduous woods, especially in riparian habitats, these mushrooms fruit in the fall. Possibly a saprophyte of fir seed cones, they show a particular fondness for the decorative mulch ("beauty bark") used in landscaping around newly constructed buildings. In fact, they are common in urban and suburban areas and are actually rare in natural settings. Ideal locations for collecting this mushroom are in the landscaped property of government facilities: courthouses, libraries, utility companies, and even police stations. Less obvious but productive locations are rhododendron, rose and azalea gardens. Frequently found along freeways, around soil mixing companies, and nurseries, these mushrooms are particularly fond of wood chip piles which are grown over with tall, broad-bladed grasses.

**Microscopic Features:** Spores are purple brown, 8-12 x 5-8  $\mu$ , ellipsoid, smooth, featuring a distinct germ pore at one end. Gill margins are banded with long throated, finger-like, non-forked or forked sterile cells. Some species have pleurocystidia while most do not. Clamp connections are present.

**Available Strains:** Strains are easy to obtain by joining a mycological society where mushrooms of this group are quietly exhibited during fall forays. In most countries (except Spain, Czechoslovakia, and others), it is illegal for companies to sell cultures except those licensed by the government.

**Mycelial Characteristics:** These Caramel Capped Psilocybes behave similarly in culture, produc-

## Growth Parameters

### Spawn Run:

Incubation Temperature: 65-75° F. (18-24° C.)

Relative Humidity: 95-100%

Duration: 45-60 days

CO<sub>2</sub>: >5000 ppm

Fresh Air Exchanges: 0-1

Light Requirements: n/a

### Primordia Formation:

Initiation Temperature: 45-55° F. (7-13° C.)

Relative Humidity: 95-100%

Duration: 10-14 days

CO<sub>2</sub>: 1000-2000 ppm

Fresh Air Exchanges: 2-4 or as needed.

Light Requirements: 400-800 lux.

### Fruitbody Development:

Temperature: 50-65° F. (10-18° C.)

Relative Humidity: 90-95%

Duration: 10-20 days.

CO<sub>2</sub>: 1000-2000 ppm

Fresh Air Exchanges: 2-4 or as needed

Light Requirements: 400-800 lux.

### Cropping Cycle:

2 crops, 3-4 weeks apart.

---

ing a luxuriantly satin-like mycelia on sterilized malt agar media. The mycelium is white, cottony at first, soon silky rhizomorphic, usually radiating outwards with diverging fans from the site of inoculation. Mycelium often, but does not necessarily, bruises bluish.

**Fragrance Signature:** Sour, unpleasant, nearly nauseating to some people, farinaceous, and reminiscent of spoiling corn.

**Natural Method of Cultivation:** This mushroom conforms to essentially the same strategy as *Stropharia rugoso-annulata*. (See growth parameters for that species.) Sawdust spawn is broadcasted into hardwood or conifer (Douglas fir) chips which have been laid down outdoors in a partially shaded environment. The wood chips should be variable in size, ranging from 1/8th inch in diameter to 4 inches in length.

**Recommended Courses for Expansion of Mycelial Mass to Achieve Fruiting:** Liquid inoculated grain spawn to 50:50 sawdust/wood chips used as spawn into outdoor beds.

**Suggested Agar Culture Media:** MYA, PDYA, OMYA or DFA.

---



Figure 292. *Psilocybe cyanofibrillosa* fruiting from Douglas fir sawdust.

**1st, 2nd & 3rd Generation Spawn Media:** Grain spawn throughout with the final stage of mycelial expansion being sawdust/chips.

**Substrates for Fruiting:** Hardwood sawdust and wood chips, especially alder, cottonwood, oak, birch, and beech. Douglas fir will also support fruitings.

**Recommended Containers for Fruiting:** Trays or framed beds outdoors.

**Yield Potentials:** Unavailable.

**Nutritional Content:** Not known to this author

**Medicinal Properties:** None authenticated. Shamans have used these mushrooms for centuries to diagnose illness. Anecdotal reports received by this author suggest a few venues for possible medical research. An elderly friend suffering from chronic hearing degeneration told me that small amounts of these mushrooms, too small to cause intoxication, had a remarkably positive effect on his hearing. Residual effects would carry over for several days. He urged me to tell others of his experiences.

These mushrooms enhance the mind's ability for complex visualization, and may possibly be a tool for controlling the autonomic nervous system. These mushrooms should be used only under the careful supervision and guidance of a physician or a shaman. Those unprepared for this experience often suffer from attacks of paranoia, fits of uncontrolled laughter, and other symptoms of psychological alteration.

Mushrooms of this group have been largely ignored by Western scientists for their potential me-



Figure 293. *Psilocybe azurescens* fruiting in the fall from a bed of alder chips implanted in the spring.

dicinal properties, instead focusing on their short-lived effects on the central nervous system. It is highly unlikely a mushroom would manufacture 1% of its biomass in a crystalline form for no evolutionary advantage. As drugs, the active compounds—psilocybin & psilocin—have virtually no apparent addictive potential for humans. These compounds act as short-lived anti-metabolites for serotonin, a primary neurotransmitter in the mammalian brain.

**Comments:** Mushrooms of this complex are rare in the wild. With the expansion of civilization, debris piles of chipped wood have accumulated around human dwellings. This rapidly emerging ecological niche has been quickly exploited by the Caramel Capped Psilocybes.

Yet, I am still mystified that in over twenty years of collecting, and in talking to dozens



Figure 294. A Sacred Psilocybe Patch.

other collectors, that the *P. cyanescens* group has not yet been found in purely natural settings in the Pacific Northwest of North America. Two possibilities: either these mushrooms are exceedingly rare in nature, evolving from micro-niches (such as a minor player in saprophytizing fir cones), and are now undergoing a population explosion; or these species were just recently introduced from Australia or Europe. The European *P. serbica* Moser & Horak and *Psilocybe bohemica* Sebek, and the Australian *P. australiana* Guzman & Watling (= ?*P. subaeruginosa* Clel.) fall into the Caramel Capped *Psilocybe* complex. In any case, the sudden availability of chipped wood for use in landscaping has brought these autumnal species to the forefront of all the mycoflora found in suburban and urban settings. They all thrive on paper products, especially cardboard, quickly projecting exquisitely formed, thick white rhizomorphs. (See Figure 96).

Many gardeners unsuspectingly grow these mushrooms in the course of cultivating ornamental plants, especially rhododendrons and roses. Since mushrooms in this group are some of the few that thrive well into November in Washington and Oregon, the mycological landscaper is blessed with mushrooms at a time when few others are in their prime.

---

## The King Stropharia of the Genus *Stropharia*

### *Stropharia rugoso-annulata* Farlow apud Murrill

**Introduction:** Majestic and massive, few mushrooms are as adaptive as *Stropharia rugoso-annulata* to outdoor cultivation. Popularly grown in Europe, this species is now the premier mushroom for outdoor bed culture by mycophiles in temperate climates. Known for its burgundy color when young, and its mammoth size, this mushroom is rapidly gaining popularity among mycologically astute recycling proponents.

Although *Stropharia rugoso-annulata* can be cultivated in growing rooms, commercial cultivation seems uneconomical when compared to the yields achieved from other mushrooms. The time from spawning to cropping is nearly 8-10 weeks, slow by any standard. The casing layer can not be fully heat treated without significant reduction in yields. And, unpasteurized casing soils, when kept for prolonged periods of time in humidified growing rooms, tend to contaminate with a plethora of green molds and other weed fungi. With peat moss based casing, low temperature pasteurization @ 130-140° F. (54-60° C.) for only 30 minutes—may be the best course for indoor cultivation. I also recommend experimentation with soaking a synthetic casing material composed of water crystals and vermiculite with a bacterially enriched water. This type of casing could stimulate fruiting by providing the essential microflora without encouraging competitor molds. Until the gestation period can be shortened for indoor cultivation, the most practical method, given time, effort, and money, is outdoors in shaded beds of wood chips and straw.

**Common Names:** King Stropharia  
Garden Giant or Gartenriese  
Burgundy Mushrooms  
The Wine Cap  
Wine Red Stropharia  
Godzilla Mushrooms

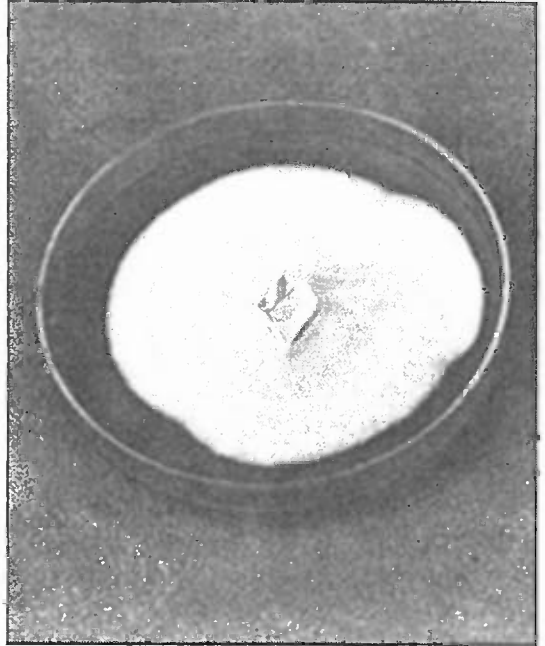

Figure 295. Typical *S. rugoso-annulata* mycelium 10 days after inoculation onto malt extract agar medium.

**Taxonomic Synonyms & Considerations:** At various times, called *Stropharia ferrii* Bres. or *Stropharia imaiana* Benedix.

**Description:** Cap 4-13 cm. reddish brown at first, fading in age, broadly convex to plane at maturity. Margin incurved at first, connected by a thick, membranous veil. Veil breaking with age to form a thick membranous ring radially split with gill-like ridges, usually darkened with spores. Teeth-like veil remnants often seen at the time the ring separates from the cap. Stem thick, equal, enlarging towards the base where thick, white radiating rhizomorphs extend.

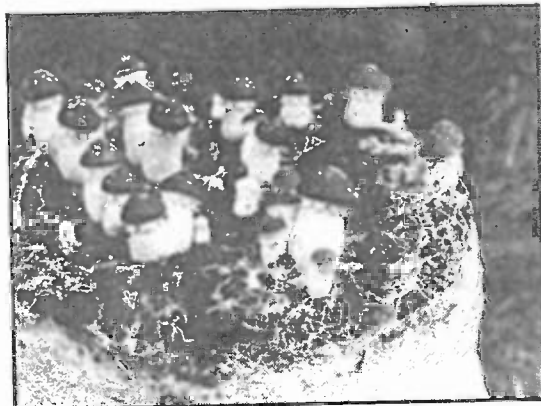

Figure 296. *S. rugoso-annulata* fruiting from wheat straw topped ("cased") with a layer of soil.

**Distribution:** This mushroom is especially common in the mid-Atlantic states like New York, New Jersey, and Massachusetts. Although first described from North America in 1922, this mushroom is now found in Europe, New Zealand and Japan. This mushroom probably became widely distributed through the export of ornamentals and wood chips. Yokoyama has deposited a strain in the culture library of the American Type Culture Collection (ATCC # 42263 = IFO 30225) isolated from rice straw.

**Natural Habitat:** In hardwood forests and/or amongst hardwood debris or in soils rich in undecomposed woody matter, especially common in the wood chip mulch used in outdoor urban/suburban plantings of ornamentals.

**Microscopic Features:** Spores purple brown, giving a purplish black spore print, measuring 11-13 x 7.5-8  $\mu$ , smooth, ellipsoid. Clamp connections present.

**Available Strains:** "Vinetou," a popular European strain and "Olympia", a widely distributed strain from the Pacific Northwest of North America

**Mycelial Characteristics:** Whitish, linear to longitudinally radial, not aerial, comparatively slow growing. Mycelium in culture lacks the pronounced rhizomorphs seen in nature. Under sterile conditions, the mycelium is cottony, not aerial, and often flattens with differentiated plateau-like formations. (If the culture dishes are taped with Parafilm®, the mycelium becomes aerial.) After prolonged incubation on grain, the mycelium secretes a clear, yellow, metabolic exudate. If not transferred to new media and allowed to over-incubate, this highly acidic exudate jeopardizes the vitality of the host mycelium. This fluid may have interesting pharmacological, antibiotic, and/or enzymatic properties and, to my knowledge, has not yet been analyzed.

**Fragrance Signature:** A unique, strong, phenolic-like fragrance is imparted by the mycelium after colonizing grain. Once on sawdust, the mycelium out-gasses a rich, pleasing, and forest-like scent.

**Natural Method of Outdoor Cultivation:** This mushroom can be easily transplanted, a technique





Figure 297. Azureus Stamets holding 4 lb. specimen of *S. rugoso-annulata*.

first used by wild collectors—whether they were aware of it or not. The trimmings from the base of the stem, resplendent with thick white rhizomorphs, quickly re-grows when placed in contact with moist wood debris. Collectors of wild mushrooms found this mushroom growing in their backyards, aggressively seeking compost piles, sawdust or straw mulched soils. With the advent of commercial spawn, debris mounds are now designed and constructed with *Stropharia rugoso-annulata* in mind.

Our family grows *Stropharia rugoso-annulata* in two ways. Our preferred method is to inoculate wood chips provided by our county utility company. (We live in a rural area with little automobile traffic.) The mixture of wood chips is mostly alder, with some Douglas fir and hemlock mixed in. Our only prerequisite is a minimum of leafy matter, which means we like to acquire our chips before mid-April, a perfect time for inoculation. Trucks dump sev-

eral loads of chips into a pyramidal pile. Using metal rakes (and a tractor), we spread the pile until it is a depth of about one foot. (Down-hill sides of the pile can get up to three feet in depth. The exposed surface face of the down-hill slope, provides adequate aeration and discourages activity from anaerobic organisms.) Upon this pile we use a 5 lb. bag of sawdust/chip spawn per 100 square feet as our minimum inoculation rate and up to 4 units of spawn for a concentrated inoculation rate. For the first four days, I heavily water using a standard yard sprinkler. Subsequently, I water for 1/2 hour in the morning and evening, unless of course, it's been raining.

In two to three weeks, rhizomorphs can be detected in their first stages of growth. In eight weeks, island colonies are distinct and abundant, usually separated by a few feet. The inoculated spawn creates island colonies which quickly become iceberg-like in formation, seeking the moist chips below and stimulated by the bacteria and nutrients near the wood/soil interface. These pyramidal colonies gradually expand to the surface. In twelve weeks, a large contiguous mycelial mat has formed. Provided that temperatures at ground level exceed 60° F. (15-16° C.), fruitings can be abundant beginning in late July to the end of September. *Stropharia rugoso-annulata*, like *Agaricus augustus*, the Prince, is a summer mushroom in the Pacific Northwest of North America. The mycelium is, however, tolerant of extreme temperature swings, thriving in a 40-90° F. (4-32° C.) window.

Breaks or flushes of mushrooms can first be seen as smooth, reddish “stones”, as if strewn into the wood chips by a playful child. As soon as they are touched, you realize that these “stones” are primordia. And for primordia, they are enormous, measuring an inch or two across. The cultivator is well advised to establish a standard walkway so that young mushrooms, unseen, are not crushed underfoot.



Figure 298. A happy mycophile holding a 3 lb. specimen of *S. rugoso-annulata*.



Figure 299. LaDena Stamets amongst 5 lb. specimens of *S. rugosa annulata*.

Hungarians have pioneered an interesting version of companion planting. King Stropharia mushrooms are grown in rows of baled wheat straw. The wheat straw is then wetted and inoculated with pasteurized, chopped wheat straw spawn. (This is called "substrate spawn".) Long rows of impregnated wheat straw are left to decompose in fields, adjacent to rows of other crops. Mushrooms usually arise from the straw/soil interface, and can be harvested during the late summer and early fall. After the growing season has ended, the straw and waste cornstalks are tilled under, enriching the soil for next year's crops.

**Recommended Courses for Expansion of Mycelial Mass to Achieve Fruiting:** This is a mushroom which greatly benefits from being disturbed or agitated. In the laboratory, the mycelial growth rate steadily declines unless it is frequently disrupted. To achieve the rapid colonization of mycelium on grain, liquid inoculation is recommended. Otherwise growth is painstakingly slow, thereby allowing more opportunity for contamination. Once grain spawn is grown out, a single half gallon of spawn can functionally inoculate 5-10 5 lb. bags of sterilized hardwood sawdust or finely chopped cereal straw. If liquid inoculation is chosen for transfer into sterilized sawdust, two to four colonies of mycelium grown out in 100 x 15 mm. petri dishes is recommended per 1000 ml. of sterile water. The inoculum is then transferred at a rate of 50 ml. per 5 lb. bag of bulk substrate. In either case, once inoculated, this species enjoys frequent shaking, at least weekly, until full colonization is seen. After the bag cultures have matured, they can be used for expansion into another generation of bags containing sterilized bulk (sawdust or straw) at a rate of 1:10. Again, thorough shaking on a weekly basis is critical for complete colonization.

---

## Growth Parameters

### Spawn Run:

Incubation Temperature: 70-80° F. (21-27° C.)

Relative Humidity: 95-100%

Duration: 25-45 days

CO<sub>2</sub>: > 20,000 ppm

Fresh Air Exchanges: 0-1 per hour

Light Requirements: n/a

### Primordia Formation:

Initiation Temperature: 50-60° F. (10-16° C.)

Relative Humidity: 95-98%

Duration: 14-21 days

CO<sub>2</sub>: <1500 ppm

Fresh Air Exchanges: 4-8 per hour or as needed to affect CO<sub>2</sub>

Light Requirements: 100-500 lux.

### Fruitbody Development:

Incubation Temperature: 60-70° F. (16-21° C.)

Relative Humidity: (85) 90-95%

Duration: 7-14 days

CO<sub>2</sub>: < 1500 ppm

Fresh Air Exchanges: 4-8 per hour

Light Requirements: 100-500 lux.

### Cropping Cycle:

2 crops, 3-4 weeks apart.

---

**Suggested Agar Media:** MYA, PDYA, OMYA or DFA.

**1st Generation Spawn Media:** Grain (rye, wheat, milo, sorghum, or corn) should be inoculated from 3-4 day fermented mycelium. (A high inoculation rate is required if not using liquid inoculation techniques.) Spawn jars should be shaken every 3-4 days after inoculation to ensure full colonization. On sterilized grain, after being disturbed, the mycelium of this species revitalizes, bursting into new growth.

**2nd & 3rd Generation Spawn Media:** A second generation of grain spawn can be inoculated from the 1st generation and then the grain spawn can be mixed into a moistened 50:50 sawdust/chips blend. A minimum of a 10% inoculation rate should be used, or preferably a rate of 15-20%.

**Fruiting Substrates:** For indoor cultivation, pasteurized straw or sterilized sawdust is inoculated with grain spawn and incubated under high carbon dioxide conditions. Once colonized, a microbially rich soil (a "casing layer") is placed upon it to promote fruiting. This soil can be heat treated to kill insects but should not be exposed to temperatures higher than 140° F. (60° C.) for more than one hour.

---



Figure 300. Representative fruiting of *S. rugoso-annulata*.

Otherwise, the mushroom-promoting bacteria are killed, hindering or preventing fruitings. Two to three weeks after casing, long, silky white, braided rhizomorphs appear, soon giving rise to dark red-brown primordia. (See Figure 296). Spent Shiitake or Oyster production blocks (sawdust/chips/bran) can be re-sterilized for further reduction by *Stropharia rugoso-annulata*.

**Recommended Cropping Containers:** Trays or 20+ gallon bags.

**Harvest Hints:** For best flavor, this mushroom must be picked before or at the time the veil is tearing along the cap margin. As soon as the gills become dark gray, signifying the production of spores, edibility precipitously declines. The bulbous stem is particularly succulent, the presence of maggots notwithstanding.

**Form of Product Sold to Market:** Fresh mushrooms are sold at farmer's markets, usually by small organic farms selling other types of produce. The price ranges from \$ 4-7 per lb. Americans are particularly attracted to this large mushroom. I have not seen this mushroom sold in dried form. It is too large to pickle.

**Nutritional Content:** Not known to this author.

**Medicinal Properties:** Not known to this author.

**Flavor, Preparation & Cooking:** Young buttons, sometimes weighing 1/2 to 1 lb. apiece, can be cut lengthwise to create King *Stropharia* steaks. Basted with soy sauce and herbal spices, this mushroom is superb on the barbecue during the summer, a time when it produces most prolifically. This mush-

room can also be used in stir fries. In either case, I prefer this mushroom well cooked.

King *Stropharia* should not be eaten for more than 2 or 3 days in a row. From European reports, some individuals who daily consumed this mushroom, fail to rebuild the enzymes necessary for digestion, an event possibly activated by alcohol, resulting in a bad case of indigestion and/or nausea. I know of one, formerly enthused King *Stropharia* grower, who grew several hundred pounds of this mushroom, featuring it at summer garden parties. Upon his third day of imbibing, he was the only one of twenty guests, to experience extreme gastrointestinal revolt. To this day, he now views King *Stropharia* (and me) with great suspicion.

**Comments:** *Stropharia rugoso-annulata* is a mushroom with complex biological requirements, and yet one of great utility for gardeners and recyclers. On sterilized malt agar media, the mycelium grows anemically. On sterilized grain and sawdust, the mycelium grows out from the site of inoculation for a few inches and then radically declines in its rate of growth. Unless the mycelium is disturbed, growth falters. If at this stage, the grain or sawdust is disturbed, the mycelium recoils from the concussion and bursts into a period of new growth. Often times, the mycelium must be disturbed several times to assure full colonization on sterilized substrates. When pasteurized sawdust is inoculated, the growth pattern is unhampered, unless green molds proliferate. The color of the sawdust changes from a dark brown to a light yellow brown just prior to the appearance of the white rhizomorphic mycelium.

Once the mycelium is implanted into wood chips outdoors, the mycelium undergoes a radical transformation in its pattern of growth. The mycelium is activated by microflora in soils, particularly bacteria. In response, thick cord-like and braided rhizomorphs form. This luxurious mycelium spreads from the sites of inoculation, and can travel substantial distances, generating satellite colonies, often hundreds of feet away from the mother colony. One mixed wood chip bed I inoculated had a depth of one to two feet, measuring approximately 20 by 30 feet in size. This patch yielded at least 200 lbs. of mushrooms over its two year lifespan. After 3 years, the wood chips were rendered into a rich soil-like humus. (See Figure 18).

Young specimens of this mushroom have an excellent flavor. The flavor quality steadily, nay, precipitously, declines as the mushroom matures, evidenced by the darkening of the gills, a sign of spores maturing. Once the thick veil ruptures and the gills throw spores, the mushroom rapidly loses any gourmet qualities. The mushrooms can weigh up to 5 lbs.



Figure 301. LaDena Stamets with King *Stropharia* at the ideal stage for harvest.

apiece. When these giants mature, with their huge surface areas of sporulating basidia, the spore cast is phenomenal. King Stropharia's flesh is far denser when young than when the caps are fully expanded. The stem is also edible although it is often permeated through with maggot holes, nearly invisible in young specimens. In older specimens the huge stems often become hollow carcasses in which so many fattened maggots have grown that the mushrooms spontaneously move from the rumblings of these inhabitants.

Another preferred method is to inoculate a mulched bed of moistened wheat straw in the garden and/or amongst shrubbery. I have found that specimens grown on wheat straw in open settings are relatively free of insect invasion compared to those grown on wood chips. For more information on the incorporation of this mushroom into an integrated farm model, please refer to Chapter 5: The Stametsian Model: Permaculture with a Mycological Twist on page 41.

See also Ingle (1988), Chilton (1986), Stamets & Chilton (1983) and Steineck (1973).



## The Paddy Straw Mushroom of the Genus *Volvariella*

Prodigiously fast growing and one of my favorite mushrooms for for the table, this mushroom thrives at warm temperatures (between 75-95° F. or 24-35° C.) and dies when temperatures drop below 45° F. (7° C.). This temperature range limits its cultivation in all but the warmest climates or months of the year. In subtropical and tropical Asia, many farmers rely on the cultivation of *V. volvacea* as a secondary source of income, making use of waste rice straw and cottonseed hulls. This mushroom has become an economic mainstay in the agricultural economies of Thailand, Cambodia, Vietnam, Taiwan and China.

Two methods have evolved for its cultivation. The first method is outdoors, simple, and low-tech, owing its success to the rapidity of *V. volvacea*'s life cycle. The second method has been developed for intensive, indoor commercial cultivation, more closely resembling the composting procedures practiced by the *Agaricus* industry in the promotion of Actinomyces colonies, except that manure is not employed.

### *Volvariella volvacea* (Bulliard: Fries) Singer

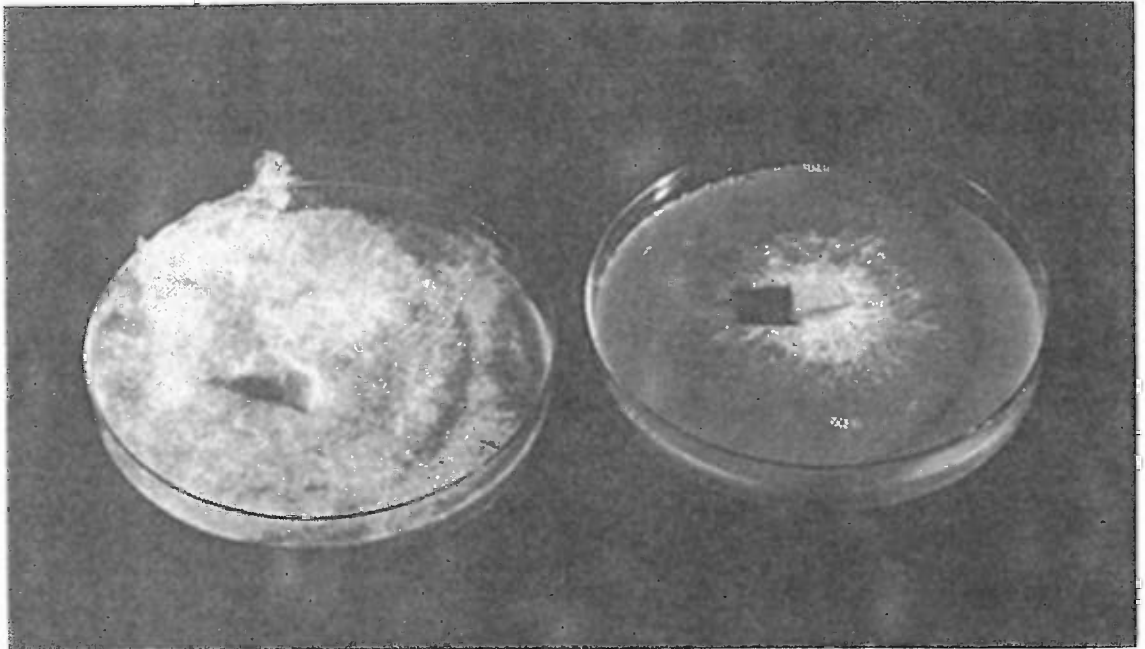

Figure 302. *V. volvacea* mycelia at 4 and 2 days after inoculation onto malt extract agar.

**Introduction:** Once you have tasted fresh Paddy Straw mushrooms, it is easy to understand the high esteem this mushroom has attained in Asia. I find fresh *V. volvacea* to be one of the best of all edible

\* Canned Paddy Straw mushrooms lack the richness of the fresh fruitbodies.

mushrooms. The duration from inoculation to fruiting is awesomely fast, giving competitors little opportunity to flourish. The Paddy Straw Mushroom is an ideal species for the low-tech cultivation by rural people in subtropical and tropical climates. After the rice harvest, farmers mulch their rice straw into mounds, and inoculate them with commercial spawn. This companion method of farming has given economic stability to many rural populations, providing a much needed supplementary income to rice farmers during the off-season.

**Common Names:** Paddy Straw Mushroom  
Straw Mushroom  
Chinese Mushroom  
Fukurotake (Japanese)

**Taxonomic Synonyms & Considerations:** *V. volvacea* and *V. bakeri* (Murr.) Shaffer are synonymous, according to Vela and Martinez-Carrera (1989).

**Description:** As the name implies, this mushroom's most distinctive feature is its volva, or cup, and resembles a classic *Amanita* except that an annulus is lacking and its spores are salmon-pink. The cap is 5-15 cm. broad, egg-shaped at first, soon expanding to campanulate or broadly convex with a slight umbo, smoky brown to cigar-brown to blackish brown, darker when young, fading in age and/or with exposure to light. Margin edge radially ridged. Gills free, white at first, soon pinkish, close to crowded. Stem 4-20 cm. long x 1.0-1.5 cm. thick, white to yellowish, solid, and smooth. The stem base is encased in a thick volva.

**Distribution:** Thriving throughout tropical and subtropical Asia, this mushroom grows singly or in groups. Also found in eastern North America in hot houses, composts, or soils, especially in the southeastern states. Discarded experiments from the University of British Columbia in Vancouver, Canada are suspected in creating a recurring patch of the Paddy Straw mushroom which persisted for nearly a decade. (Kroeger (1993)).

**Natural Habitat:** On composting rice straw, sugar cane residue, leaf piles, and compost heaps during periods of warm weather from the spring through autumn. Several reports of this species growing in northern temperate climates have been traced to "escapees" from mushroom cultivators.

**Microscopic Features:** Spores pink to salmon brown, (6) 7.5-9 x 4-6  $\mu$ . Cheilocystidia, pleurocystidia and chlamydospores are present.

**Available Strains:** Widely available, both from wild and developed stocks. Strains of *V. volvacea* die under cold storage. Many cultivators have found that cultures store best at ambient room temperature (i.e. above 45 ° F. ( 7.2° C.)). Cold weather strains have yet to be developed. For more information, consult Jinxia & Chang (1992) and Chang (1972).

**Mycelial Characteristics** Longitudinally linear soon aerial and disorganized, greyish white at first, soon, dingy yellowish brown, eventually becoming light gray brown to reddish brown, often with complex discolored zones.

**Fragrance Signature:** Mycelium musty, not pleasant to this author.

**Natural Method of Cultivation:** On rice straw using a simple composting technique. Straw and cot-

---





Figure 303. Soaked straw is thrown into a tapering, trapezoid-shaped form.



Figure 304. Soaked cottonseed hulls are thrown around the outer inside edge of the frame and then inoculated with grain spawn. Additional layers are built in the same fashion.

hulls are soaked for 2-7 days, allowed to ferment, and then layered onto the straw at the rate equivalent to 10-20% of the rice straw. For outdoor cultivation, spawn is added directly to the cottonseed hulls as each layer is built. The mass is covered with the goal of obtaining at least 90° F. (32° C.) for the next 5-7 days.



Figure 305. After 4-6 layers, the frame is lifted off, and the process begins anew.

tonseed hulls are separately submerged in water. Saturated straw is laid directly on the ground in approximately a 2 ft. x 2 ft. square; to a 2-3 inch depth. See Figures 303 through 305.

**Recommended Courses for Expansion of Mycelial Mass to Achieve Fruiting:** Traditional or liquid fermentation methods work well for spawn generation. Indoors, commercial cultivators use a single stage composting schedule that contrasts with the methods Button mushroom growers use.

Rice straw is chopped into 4-5 in. (10-12 cm.) pieces, soaked and stacked outside to tenderize the straw for no more than two days. A moisture content of 75% is desired. Cottonseed



Figures 306-307. Multiple square or rectangular mounds can be created and covered with plastic or a heavy layer of straw which is kept moist.



Figure 308. In as short as 7 days, mushrooms form. A hoop frame covered with plastic helps maintain humidity and warmth at night during the primordia formation period.



Figures 309. The outdoor harvest can be substantial.

For indoor cultivation, the mass is mixed together and bulked steamed at 120-140° F. (49-60° C.) for 2-4 days. The nitrogen-rich cottonseed hulls and other supplements contribute to the self-heating of the substrate. When the mass is cooled to 90-100° F. (32-38° C.), grain spawn is thoroughly mixed through. The bed temperature is usually 15-20° F. (8-12° C.) above room temperature during colonization. 4-5 days after spawning, a moist, shallow casing layer can be provided to stimulate even mushroom formation, which usually occurs 4-6 days later.

**Suggested Agar Culture Media:** MYA, OMYA and PDYA.

**1st, 2nd & 3rd Generation Spawn Media:** Rice, rye, wheat, sorghum, milo, corn, millet in liter or quart bottles. The final spawn is usually provided in convenient-to-use 5-10 liter plastic bags.

**Substrates for Fruiting:** Straw, preferably rice, hardwood sawdusts. Wheat straw also supports

---

## Growth Parameters

### Spawn Run:

Incubation Temperature: 75-95° F. (24-35° C.)  
Relative Humidity: 80-95% rH  
Duration: Day 5-10 days  
CO<sub>2</sub>: > 5000 ppm  
Fresh Air Exchanges: 1  
Light Requirements: No light

### Primordia Formation:

Initiation Temperature: 80-90° F. (27-32° C.)  
Relative Humidity: 90-100 %  
Duration: 4-6 days  
CO<sub>2</sub>: 1000-5000 ppm  
Fresh Air Exchanges: 4-5  
Light Requirements: 250-500 lux.

### Fruitbody Development:

Temperature: 80-90° F. (27-32° C.)  
Relative Humidity: 85-95%  
Duration: 6-10 days.  
CO<sub>2</sub>: 1000-5000 ppm  
Fresh Air Exchanges: 4-5  
Light Requirements: 500-750 lux.

### Cropping Cycle:

7-12 days.

---

fruitings, although not nearly as well as supplemented, composted rice straw. One study showed that the best supplement for wheat straw is wheat bran (5%) and/or cotton hulls (10%). (See Li et al., 1988). The pH optimum for fruiting falls between 7.5 - 8.0.

**Recommended Containers for Fruiting:** Trays, bags. Outdoor methods use no containers. The substrate is shaped into long rectangular mounds, narrowing at the top. The frames are covered with loose rice straw, cloth or plastic to retain humidity.

**Yield Potentials:** On average, *V. volvacea* produces two substantial flushes of mushrooms in quick succession, with the first giving 75% of the total yield and the second producing the remaining 25%.

**Harvest Hints:** For the best flavor as well as the best form for market, the mushrooms should be picked before the universal veil breaks, i.e. in the egg form. In the matter of hours, egg-shaped fruitbodies develop into annulate fruitbodies. Light has a governing influence on the color and overall quality of the harvestable crop.

---

**Form of Product Sold to Market:** Fresh to local markets and usually canned for export. Rarely sold in a dried form.

**Nutritional Content:** 26-30% protein, 45-50% carbohydrates, 9-12% fiber and 9-13% ash. According to Ying (1987), this mushroom is rich in vitamins C & B, minerals and assorted amino acids.

**Medicinal Properties:** None known to this author.

**Flavor, Preparation & Cooking:** Sliced thin and stir-fried or as a condiment for soups. Used in a wide array of Asian dishes. I like to inject onion soaked soy (or tamari) via syringe into each Paddy Straw egg, cover with foil, and bake in an oven at 375° F. (190° C.) for 30-45 minutes. This mushroom, when eaten whole, explodes in your mouth creating a flavor sensation *par excellence*. Canned Paddy Straw mushrooms fail to provide a flavor experience comparable to fresh *V. volvacea*.

**Comments:** This mushroom is widely cultivated by farmers in China, Thailand, Vietnam and Cambodia for supplemental income. The egg-form is self-preserving, limiting the loss of moisture and extending shelf life.



Figure 310. Paddy Straw mushrooms are best in their egg-form.

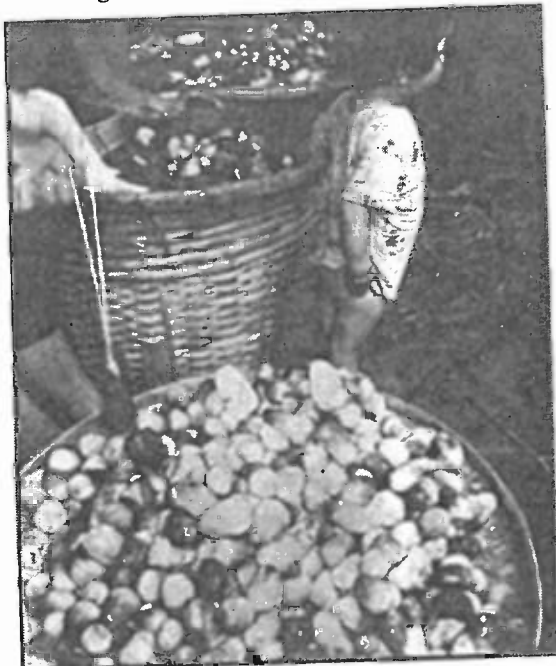

Figure 311. In China, Paddy Straw mushrooms are sold in great quantities in outdoor markets.

This mushroom can be grown on uncomposted straw-based substrates although yields are substantially improved if the substrate is "fermented" or short-cycle composted. If rice straw is composted with supplements for 4-5 days, pasteurized, and inoculated, yields can be maximized. "Green composting" is the simultaneous inoculation of the compost while it is being formulated. The heat generated within the composting straw/cottonseed hull mass accelerates the growth of the thermophilic and heat tolerant *Volvariella volvacea*.

Cultivating the Paddy Straw mushroom is difficult in most regions of North America. Louisiana, Georgia, Alabama, and certain coastal regions of Texas have climates suitable for outdoor cultivation as does regions of Mexico. Should temperatures fall below 70° F. (21° C.) for any period of time, fruitings will be limited and the critical increase in temperature

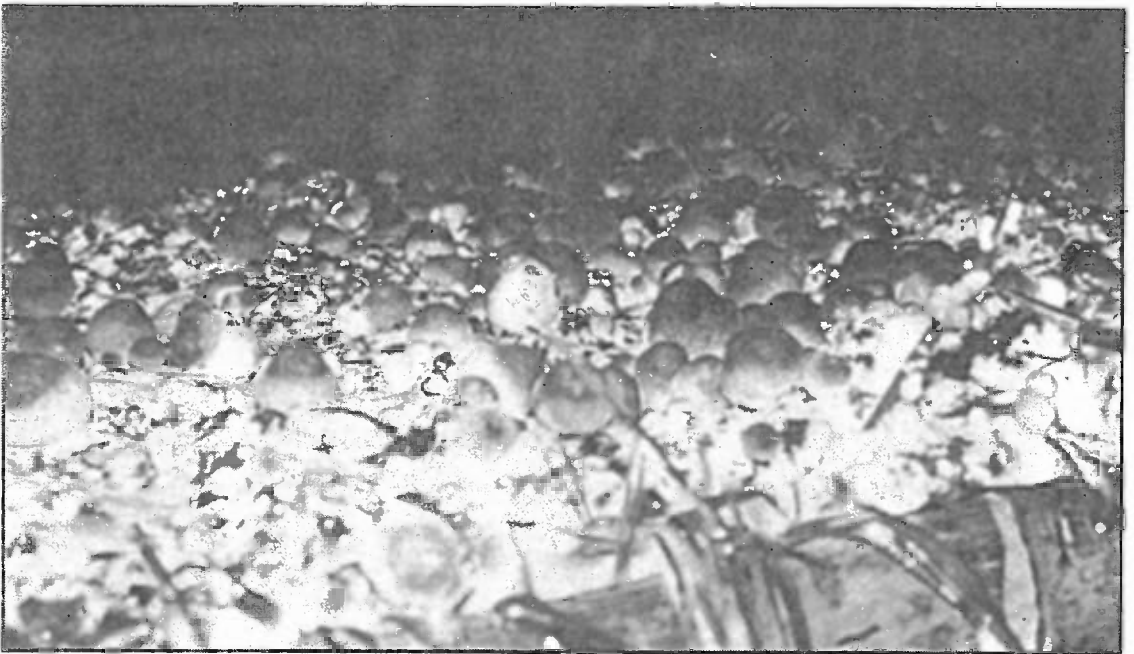
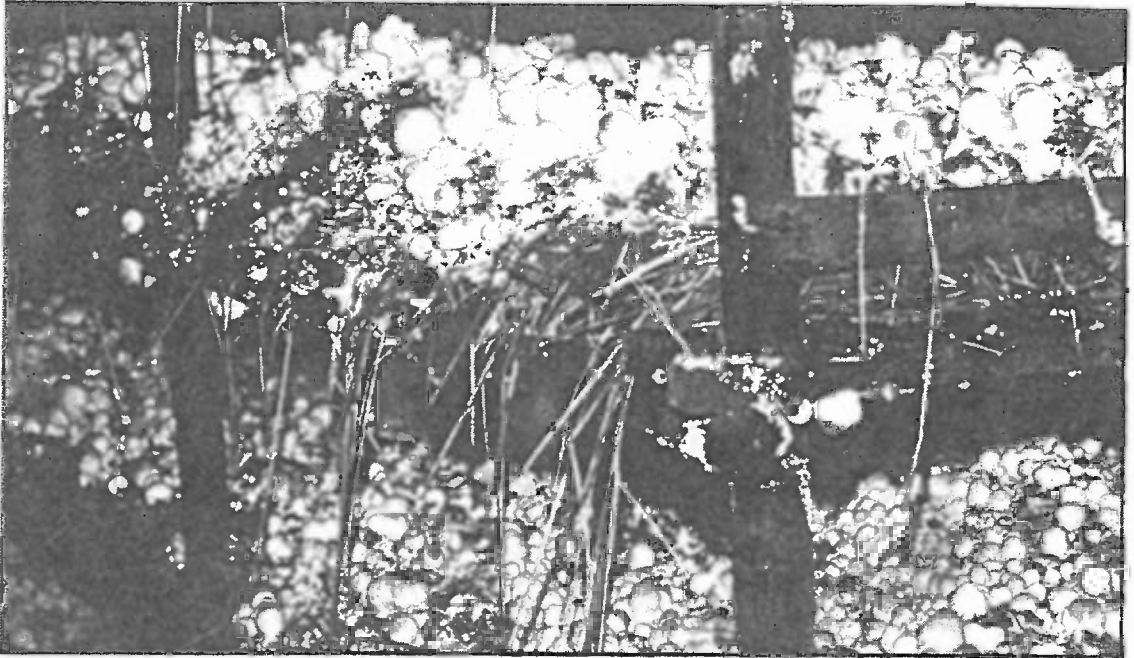

Figure 312-313. Paddy Straw mushrooms fruiting on pasteurized rice straw beds in Thailand.

caused by thermogenesis will be forestalled. Additionally, most cultures die when chilled below 45° F. (7.2° C.) unless they are flash-frozen in liquid nitrogen.

The most comprehensive, English language book, on the cultivation of this mushroom is by S.T. Chang, published in 1972 entitled *The Chinese Mushroom (Volvariella volvacea): Morphology, Cytology, Genetics, Nutrition and Cultivation*. This book is now out of print and is much sought after. It needs to be reprinted. See also Ho (1971).

---

---

I N D O O R   G R O W T H   P A R A M E T E R S

# The Polypore Mushrooms of the Genera *Ganoderma, Grifola* and *Polyporus*

**T**he use of Polypores spans millennia and, of all the medicinal mushrooms, they reign supreme. Polypores are more often incorporated into the pharmacopeia of native peoples than any other type of mushroom. Historically, cultures from tropical Amazonia to the extreme northern sub-polar zones of Eurasia have discovered the power of Polypores in preserving and improving human health. Polypores have also figured prominently in the cosmological view of native peoples, often being referred to as sources of eternal strength and wisdom.

The Agaria of Sarmatia, a pre-Scythian culture, used a Polypore at the time of Christ to combat illness. They bestowed this Polypore with the name of *agarikon*, undoubtedly to honor its value to their society. The Greek philosopher Dioscorides, recorded its name as *agaricum* circa 200 A.D. Its use persisted throughout the Middle Ages and tea made from this wood conk was prescribed as one of the herbal remedies for tuberculosis.

Researchers believe this mushroom was *Fomitopsis officinalis*, a canker parasite of conifer trees. This same Polypore species has been retrieved from the graves of Pacific Northwest Coast Indian shamans. Thirteen individual carvings of this wood conk were collected in the late 1800's and mistakenly thought to be wood carvings until Blanchette et alia (1992) studied them. Used as a poultice to relieve swellings, inflammations, and sweating, this conk was called "the bread of ghosts", and thought to impart supernatural powers. In Haida mythology this or another Polypore (such as *Ganoderma applanatum*) is directly connected the origin and protection of the female spirit.

Recently, in the winter of 1991, hikers in the Italian Alps came across the well preserved remains of man who died more than 5300 years ago. Dubbed the "Iceman" by the news media, he was well equipped with a knapsack, flint axe, and a string of dried Birch Polypores. (Birch Polypores, *Polyporus betulinus*, are now known as *Piptoporus betulinus*). These Polypores, like many others, can be used as tinder, for starting fires, and medicinally, in the treatment of wounds. Further, by boiling the mushrooms, a rich tea with anti-fatiguing, immunoenhancing, and soothing properties can be prepared. Of the essentials needed for travel into the wilderness, this intrepid adventurer had discovered the value of the noble Polypores. Ironically, as a group, the Polypores remain largely unexplored.

Throughout the past twenty years, I have been repeatedly told by travellers to Mexico, South America, and the Middle East of Christian churches who have for centuries paid homage to crosses in whose centers were glass spheres housing what appeared to be a species of wood conk. To this day, the identity of this revered conk remains shrouded in mystery. These are but a few examples. One naturally wonders how many species and uses have not yet come to the attention of Western science, perhaps forever obscured by the passage of time.

The most well known of the Polypores is, without question, Reishi or Ling Chi, known to mycologists as *Ganoderma lucidum*. So extensive are the medicinal claims for this fungus, this mushroom is also called the Panacea Polypore. Claimed to cure cancer, heart disease, diabetes, arthritis, high alti-



Figure 314. "Drawing of an argillite plate, carved by Charles Edenshaw in approximately 1890, depicting the Haida myth of the origin of women. Fungus Man is paddling the canoe with Raven in the bow in search of female genitalia. Of all the creatures that Raven placed in the stern of the canoe only Fungus Man had the supernatural powers to breach the spiritual barriers that protected the area where women's genital parts were located...." Redrawn from a photograph, courtesy of the Field Museum of Natural History, Chicago. (Blanchette et al., 1992, p. 122.)



tude sickness, sexual impotency, and even chronic fatigue syndrome, it is no wonder that this mushroom has been for centuries heralded as "The Mushroom of Immortality".

Two other Polypores enjoying reputations as medicinal fungi are Maitake, *Grifola frondosa*, and Zhu Ling, *Polyporus umbellatus*. Maitake has recently been found to be effective, *in vitro*, against the HIV virus by the National Cancer Institute of the National Institute of Health's anti-HIV drug screening program.\* During a visit to the Institute of Materia Medica in Beijing, *Polyporus umbellatus* was reported to Stamets & Weil (1983) as being exceptionally effective against lung cancer. Aqueous extracts (tea) were given to patients directly after radiation therapy, with promising results.

The Polypores covered in this book are Reishi (*Ganoderma lucidum*), Maitake (*Grifola frondosa* (= *Polyporus frondosus*)), and Zhu Ling (*Polyporus umbellatus* = *Grifola umbellata*). Many other Polypores, such as *Laetiporus sulphureus* (= *Polyporus sulphureus*), can be grown on stumps. Future editions of this book will expand on the number of Polypore species which I have successfully cultivated. A short list of these candidates includes, but is not limited to:

*Albatrellus* spp.  
*Daedalea quercina*  
*Fomes fomentarius*  
*Fomitopsis officinalis*  
*Ganoderma applanatum* (= *Elfvigia applanata*)  
*Ganoderma curtisii*  
*Ganoderma oregonense*  
*Ganoderma sinense*  
*Ganoderma tsugae*  
*Inonotus obliquus*  
*Oligoporus* spp.  
*Oxyporus nobilissimus* and allies  
*Phellinus* spp.  
*Piptoporus betulinus*  
*Polyporus indigenus*  
*Polyporus saporema*  
*Trametes cinnabarinum* (= ? *Pycnoporus cinnabarinus*)  
*Trametes* (= *Coriolus*) *versicolor* & allies

Polypores are premier wood decomposers, and can produce annual or perennial fruitbodies. None

\* De-replication and second tier screening studies are on-going at the time of this writing, as well as trials with AIDS-afflicted patients. The HIV virus *apparently* becomes encapsulated by a "carbohydrate condom" limiting reproduction. Hypothetically, I suspect two distinct modes of activity. First, the compounds in Maitake may stimulate the immune system by providing essential precursor-nutrients. Secondly, these compounds may also be a direct toxin to the virus. Until human studies can be funded, such hypotheses are purely speculative. However, if proven, this double-prong approach, combined with the fact that Maitake is an excellent edible and choice gourmet mushroom, brings Maitake to the forefront of the medicinal polypores. In my opinion, all polypores should be screened for their anti-cancer, anti-HIV and immuno-enhancing properties. There are probably more species with equal or greater potentials.

are known to be poisonous, although some people have allergic reactions to certain species. Some people taking MAO inhibitor anti-depressant medication can have allergic reactions to the edible polypores containing tyramine. Chicken of the Woods (*Laetiporus (Polyporus) sulphureus*) has been reported to contain alkaloids similar to those found in plants known to be psychoactive, like Kava Kava. (Lincoff & Mitchel (1977)).

The cultivation of these species can take several tracks. One track is to simply inoculate hardwood logs as with the cultivation of Shiitake. By burying the inoculated logs in sawdust or soil, moisture is better preserved, and fruitings extend over several years. Stumps can also be inoculated, although if other fungi have already captured that niche, production is inhibited. In outdoor environments, the first flushes of mushrooms are often delayed, not showing for several years after inoculation. However, since Polypores are naturally lower in moisture and require less water, outdoor patches require less maintenance than indoor methods.

By far the most dependable and rapid production system is the cultivation of Polypores indoors under controlled environmental conditions. Several techniques lead to success. One of the main differences between the cultivation of Polypores versus the fleshier, gilled mushrooms is that the Polypores do not enjoy, nor require, the heavy watering schedules and high humidities of the gilled mushrooms. Like most mushrooms, the Polypores are sensitive to carbon dioxide levels and light conditions. The development of the fruitbodies are extremely responsive to changes within the growing room environment. Many cultivators manipulate the environment to elicit substantial stem formation before cap development. Some Polypore species produce better fruitings if the substrate block is compressed after colonization. Other differences, unique to each species, are outlined in the forthcoming growth parameters.

---

## *Ganoderma lucidum* (Wm. Curtis: Fries) Karsten

**Introduction:** A mushroom of many names, *Ganoderma lucidum* has been used medicinally by diverse peoples for centuries. The Japanese call this mushroom *Reishi* or *Mannentake* (10,000 Year Mushroom) whereas the Chinese & Koreans know it as *Ling Chi*, *Ling Chih*, or *Ling Zhi* (Mushroom (Herb) of Immortality). Renowned for its health stimulating properties, this mushroom is more often depicted in ancient Chinese, Korean, & Japanese art than any other. Ling Chi is traditionally associated with royalty, health & recuperation, longevity, sexual prowess, wisdom, and happiness. Ling Chi has been depicted in royal tapestries, often portrayed with renowned sages of the era. For a time, the Chinese even believed this mushroom could bring the dead to life when a tincture specifically made from it was laid upon one's chest.

The use of *Ganoderma lucidum* spans more than two millennia. The earliest mention of Ling Chi was in the era of the first emperor of China, Shih-huang of the Ch'in Dynasty (221-207 B.C.). Henceforth, depictions of this fungus proliferated through Chinese literature and art. In the time of the Han Dynasty (B.C. 206 - A.D. 220) while the imperial palace of Kan-ch'uan was being constructed, Ling Chi was found growing on timbers of the inner palace, producing nine "paired leaves". So striking was this good omen, that henceforth emissaries were sent far and wide in search of more collections of this unique fungus. Word of Ling Chi thus spread to Korea and Japan whereupon it was elevated to a status of near-reverence.

This mushroom is known by many in North America and Europe as one of the "Artist's Conk" fungi. (The true Artist Conk is *Ganoderma applanatum*.) As the fruitbody



Figure 315. A Tibetan Ling Chi "Tree" statuette made of wood, from pre-1600 AD. revered and protected in the Lama Temple, Beijing.

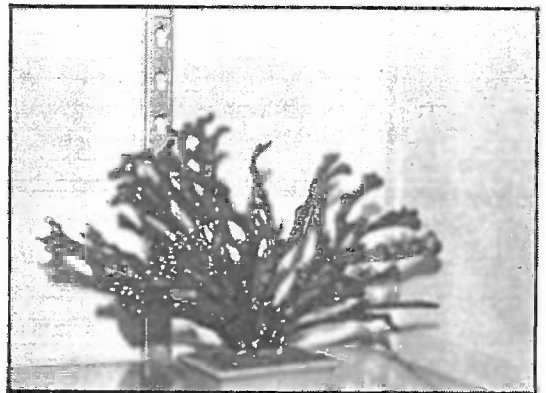

Figure 316. An exquisite antler specimen of Ling Chi featured in a Chinese mushroom museum.

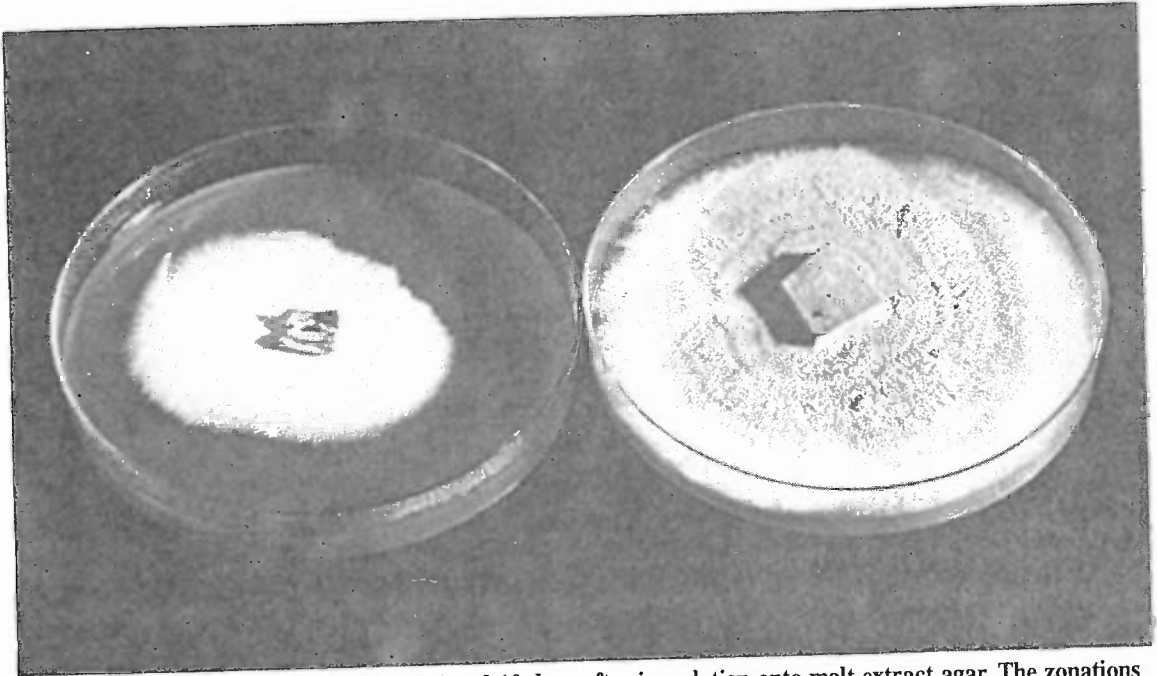

Figure 317. *G. lucidum* (ATCC #52412) 4 and 10 days after inoculation onto malt extract agar. The zonation patterns are a strain-specific feature.

develops, the spore producing underlayer—the hymenium—is white and can be drawn upon. As the pores are crushed, a browning reaction occurs, thus allowing the artist to sketch an image.

**Common Names:** Reishi (Japanese for Divine or Spiritual Mushroom)  
 Ling Chi, Ling Chih, Ling Zhi (Chinese for “Tree of Life” mushroom)  
 Mannentake (Japanese for “10,000 Year Mushroom”, “Mushroom of Immortality”)  
 Saiwai-take (Japanese for Good-fortune Mushroom)  
 Sarunouchitake (Japanese for “Monkey’s Seat”)  
 The Panacea Polypore

**Taxonomic Synonyms & Considerations:** *Ganoderma lucidum* is the type mushroom, the pivotal species around which the genus concept is centered. *Ganoderma lucidum* grows on oaks, and other hardwoods whereas two close relatives, *G. tsugae* and *G. oregonense*, grow primarily on conifers. *G. tsugae* grows on hemlocks, as its name implies, while in the southwest of North America, this species has been reported on white fir, *Abies concolor*. In culture, *G. lucidum* and *G. tsugae* develop long stems in response to manipulation of the environment. *G. oregonense* can be found on a variety of dead or dying conifers, including *Tsuga*. Knowing how mutable the formation of the stalk is under different cultural conditions, and that *Ganoderma lucidum* readily fruits on a variety of conifer and hardwood sawdust mixtures, delineation of these individuals based solely on habitat seems highly suspect.

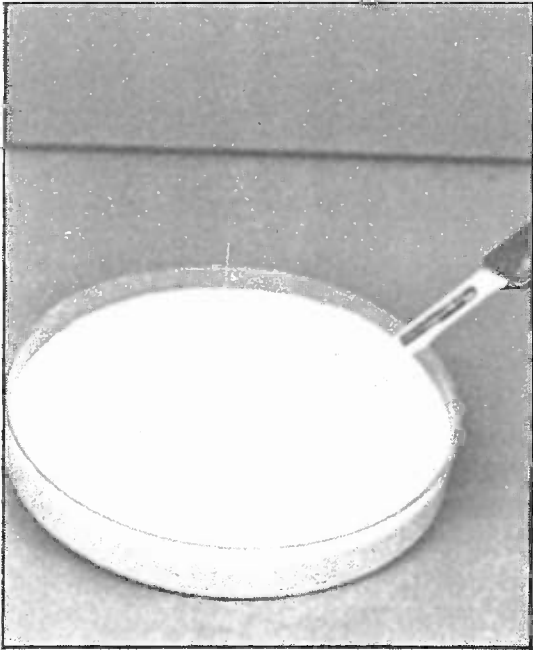

Figure 318. *G. lucidum* (Forintek's 34-D) 7 days after inoculation onto malt extract medium.

One historic and notable attempt to distinguish the North American from the Far Eastern taxa can be found in an article published by R. Imazeki (in Japanese) titled "Reishi and *Ganoderma lucidum* that grow in Europe and America: Their Differences", 1937.

Currently, the best treatises discussing the taxonomy of these polypores are Gilbertson & Ryvardeen's (1987) monograph, *North American Polypores: Vol. I & II* and Zhao's (1989) *The Ganodermataceae in China*. The spore size of *G. lucidum* is smaller than the inclusive range of 13-17  $\mu$  in length by 7.5-10  $\mu$  in width characteristic of *G. oregonense* and *G. tsugae*. Nevertheless, Gilbertson & Ryvardeen did not consider this feature to be more significant than habitat when delineating these three taxa in their Key to Species. Placing emphasis on habitat may also be a dubious distinction when considering these species produce fruitbodies on non-native woods when cultivated. Features

of higher taxonomic significance—such as interfertility studies and DNA fingerprinting—are needed to support accurate and defensible species delineation. For instance, interfertility studies with some collections reveal that *G. curtisii* (Berk.) Murr. may merely be a yellow form of *G. lucidum* common to the southeastern United States. (See Adaskaveg & Gilbertson (1986 & 1987) and Hseu & Wang (1991)).

From a collector's point of view, *G. oregonense* is a much more massive mushroom than *G. lucidum* and is characterized by a thick pithy flesh in the cap. Also *G. oregonense* favors colder climates whereas *G. lucidum* is found in warmer regions. (*G. lucidum* has not been reported from the Rocky Mountain and Pacific Northwest regions.) *Ganoderma curtisii*, a species not recognized by Gilbertson & Ryvardeen, but acknowledged by Zhao (1989) and Weber (1985) grows in eastern North America, and is distinguished from others by the predominantly yellowish colored cap as it emerges. These North American "Reishis"—*Ganoderma lucidum*, *G. curtisii*, *G. oregonense*, and *G. tsugae* represent a constellation of closely related individuals, probably stemming from a common ancestry. The argument for retaining them as separate species may be primarily ecological and host specific and not biological. One of the few cultural distinctions described by Adaskaveg & Gilbertson (1986) is that *G. lucidum* produces chlamydospores in culture whereas *G. tsugae* does not.

In Asia, *Ganoderma lucidum* has a number of unique allies. Most notably, a black stalked *Ganoderma* species, also considered to be a Reishi, is called *Ganoderma japonicum* Teng (= *Ganoderma sinense* Zhao, Xu et Zhang colloquially known as Zi zhi.)

**Description:** Conk-like or kidney-like in shape, this woody textured mushroom, 5-20 cm. in diameter, has a shiny surface that appears lacquered when moist. The cap can be a dull red to reddish brown, and sometimes nearly black in color. Featuring pores on its underside, whitish, browning when touched. Areas of new growth whitish, darkening to yellow brown and eventually reddish brown at maturity, often with zonation of concentric growth patterns. Spores dispersed from the underside, collect on the surface of the cap giving the a powdery brown appearance when dry. Stem white to yellow, eventually darkening to brown or black, eccentrically or laterally attached to the cap, usually sinuous, and up to 10 cm. in length x .5-5.0 cm. thick.

**Distribution:** This mushroom is widely distributed throughout the world, from the Amazon through the southern regions of North America and across much of Asia. This mushroom is less frequently found in temperate than in the sub-tropical regions.



Figure 319. Buried log cultivation of Ling Chi in China.



Figure 320. Shaded log cultivation of Reishi in Japan.

**Natural Habitat:** An annual mushroom, growing on a wide variety of woods, typically on dead or dying trees, primarily on deciduous woods, especially oak, maple, elm, willow, sweetgum, magnolia, locust, and in the Orient, on plums. Found on stumps, especially near the soil interface, and occasionally on soils arising from buried roots. Occurring from May through November, and more common in warm temperate regions. In the southeastern and southwestern United States, *Ganoderma lucidum* is frequently found in oak forests. In the northeastern states, this species is most common in maples groves. This mushroom often rots the roots of aging or diseased trees, causing them to fall. (This is one of the “white rot” fungi foresters know well.) From the darkened cavity of the upturned root wad, where carbon dioxide levels are naturally higher and light levels are low, long stalked mushrooms arise. These rare, multi-headed, antler-like forms are highly valued in Asia. (See Figure 316.)

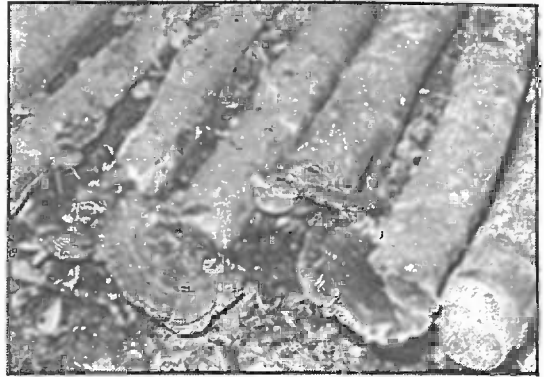

Figure 321. Shaded log cultivation of Reishi in the United States (Louisiana).

**Microscopic Features:** Spores reddish brown, ellipsoid with a blunted end, roughened as in warty, 9-12 x 5.5-8  $\mu$ , two walled, with spaced, internal “inter-wall pillars”. Cystidia absent. Clamp connections present, otherwise hyphae aseptate. Hyphal system dimitic. Chlamydospores forming in cultured mycelium.

**Available Strains:** Yellow, red, purple, and black strains are widely available from most culture libraries. New strains are easily cloned from the wild, best taken from young fruitbodies from the central flesh leading to the disc or alternatively from the edge of the developing cap margin. Because of their woody texture, a sturdy and razor-sharp surgical scalpel is recommended. Recovery or “leap-off” may take two weeks. Once in culture, many strains grow rapidly and fruit on sawdust substrates. Each tissue culturist should note that those strains isolated from conifers may actually be *Ganoderma oregonense* or *Ganoderma tsugae*. Forintek’s 34-D produces a reddish brown fruitbody and is popular amongst North American cultivators. American Type Culture Collection’s #52412, which was used as the isotype for a taxonomic discussion by Wright & Bazzalo (*Mycotaxon* 16: 293-295, 1982) produces a multitude of rapidly grown antlers. (See Figure 323).

Each strain is unique in its pattern of growth from agar media-to-grain-to-wood based substrates. A notable difference between strains is that one group, when over-incubated, makes grain spawn nearly impossible to loosen into individual kernels upon shaking. The other, smaller group of strains allows easy separation, even when over-incubated.

**Mycelial Characteristics:** Longitudinally radial, non-aerial, initially white, rapid growing, becoming densely matted & appressed, yellow to golden brown, and often zonate with age. Some strains produce a brown hymenophore on MEA. A 1 cm. square inoculum colonizes a 100 x 15 mm. petri plate in 7-10 days at 75° F. (24° C.). Soon after a petri plate is colonized (2 weeks from inoculation),



Figure 322. *G. lucidum* fruiting from pots containing inoculated oak logs topped with soil.

the mycelium becomes difficult to cut and typically tears during transfer. Culture slants can be stored for periods of 5 years at 35° F. (1-2° C.).

**Fragrance Signature:** Musty, mealy, not sweet, not pleasant.

**Natural Method of Cultivation:** *G. lucidum* can be grown via a wide variety of methods. In China and Japan, the traditional method is to inoculate logs and lay them on the ground or shallowly bury them. (See Figures 319–321). The logs are placed in a shady, naturally moist location. By covering hoop-frames with shade cloth, light exposure and evaporation is reduced, creating an ambient environment conducive for fruitbody development. Typically six months to two years pass before substantial harvests begin, and continue for four to five years. (For more information, see Hengshan et al. (1991.)) This method gives rise to natural-looking mushrooms.

Using Nature as an example, this mushroom grows prolifically on stumps. Hardwood stumps can be inoculated using any of the various methods described in this book. Cultivators living in high humidity climates with prolonged growing seasons (such as Louisiana and elsewhere in the humid southeastern United States) have success growing *Ganoderma lucidum* on hardwood logs laid directly onto the ground. Individual preferences vary amongst cultivators who, by nature, tend to be a secretive or reluctant-to-communicate breed.

A quasi-natural method is to inoculate short hardwood logs and place them into nursery style pots. (See Figure 322.) The pots are then filled with hardwood sawdust and topped with soil. Large greenhouses, covered with dense shade-cloth, can house thousands of these individual containers that are simply laid out as a single layer over a gravel rock floor.



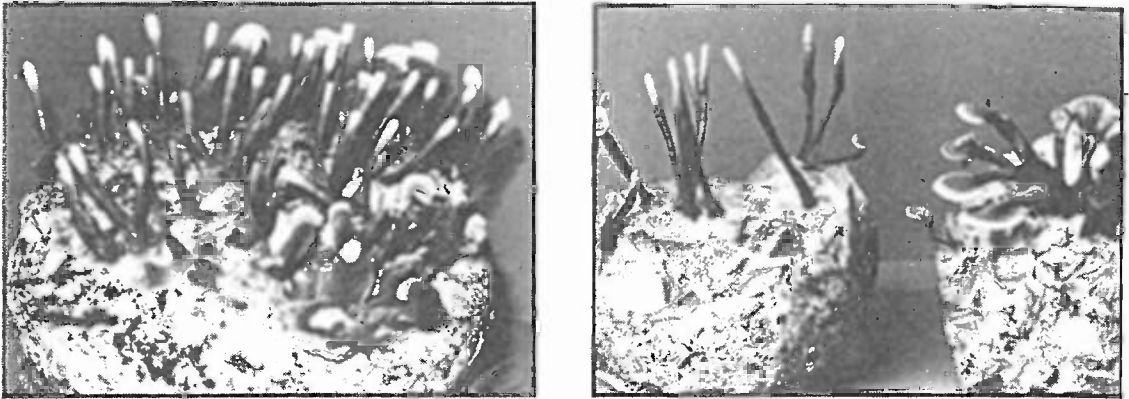

Figure 323-324. Antler formation of *Ganoderma lucidum* is controlled by the carbon dioxide of the prevailing environment. (ATCC# 52412)

**Rapid Cycle System for Indoor Cultivation:** A unique combination of variables can be orchestrated to effect fruitbody formation. The indoor method I have developed calls for spawn inoculation onto a 50:50 (by volume) hardwood sawdust/wood chip mixture incubated in polyethylene space bags. For 3-4 days, the hardwood (alder/oak) wood chips are soaked/fermented in molasses enriched water (50 ml. molasses/5 gallons water). After soaking, the 17.50 x 8.25 x 4.75 in. bags are filled to 3 lbs. wet weight. The bags are then sterilized for 2 hours at 15 psi. Upon cooling the bags are opened within a clean room. Grain or sawdust spawn is distributed equally into each bag. The bags are exposed to the airstream from a laminar flow bench, causing partial inflation. Directly thereafter, the bags are heat sealed. The bags appear domed or inflated. In effect, an idealized, positive pressurized, humidified environment is created. Slow gas exchange occurs through the semipermeable microporous filter media patch.

Colonization is usually complete in 14-21 days at 75° F. (24° C.). Thirty to forty days after inoculation, the first mushrooms begin to emerge from the rough micro-topography of the sawdust/chip media. The emerging fruiting bodies are whitish to golden yellow in color and apically triangular in shape. Growth is slow, yet noticeable from day to day. The tongue-like formations yellow with age, and becoming progressively more reddish brown towards the base. By day 50 they have often achieved 4 inches in length, are branched, having arisen from multiple sites on the surface plane of the wood chip media. Frequently, these antler-stalks seek out the filter patch and become attached to it. Once the desired height of stalk formation has been achieved, the environment must be altered so as to proceed to the final stage. If the cultivator does not expose these emerging antlers to near-natural atmospheric conditions, the opportunity for conk development will soon be lost.

For the previous two months, the entire growth cycle has occurred within the environment of the sealed plastic bag, wherein carbon dioxide and other gases exist in relatively high concentrations. Although the filter patch allows the slow diffusion of gases, it acts as a barrier to free air exchange. Often the interior plenum has carbon dioxide levels exceeding 20,000 ppm or 2%. Once the bag is opened, and a free rate of gas exchange prevails, carbon dioxide levels drop to near normal levels of 350 ppm or .035%. This sudden change in carbon dioxide levels is a clear signal to *Ganoderma lucidum* that



Figure 325. Some strains will not form stems if carbon dioxide is maintained at atmospheric levels. White margin denotes new growth.

prevail, massive evaporation will halt any fruitbody development. If the exposed block is maintained in a fog-like environment within the growing room, vertical stalk growth slows or abates entirely and the characteristic horizontal kidney-shaped cap begins to differentiate. Like the stalk, the margins of new growth are whitish while the aged areas take on a shiny burgundy brown appearance.

Cultivators in Asia inoculate 1-2 liter cylindrical bags or bottles, narrowly closed at one end and stopped with a cotton plug. Once inoculated, the bags or bottles are stacked horizontally in a wall-like fashion. After 30-60 days, depending upon the strain, inoculation rate, and growing conditions, the cotton filters are removed. The small opening channels  $\text{CO}_2$  stimulating stem elongation. This same opening is also the only conduit for moisture loss. From this portal, finger-like primordial shoots

cap development can begin.

In its natural habitat, this change is analogous to the stalk emerging from the rich carbon dioxide environment below ground level. Once the  $\text{CO}_2$  sensitive stalk emerges into the open air, the photosensitive, spore producing lateral cap develops. The caps form above the plateau of the ground and orient towards directional light. An indication of new growth is the depth and prominent appearance of a white band around the cap's edge. Under these conditions, cap formation is rapid and the time of harvest is usually indicated by the lack of new margin growth and the production of rusty brown spores. The spores, although released from below, tend to accumulate on the upper plane of the cap.

The cultivator has two alternatives for eliciting conk development once antlers have begun to form. The plastic bag can be left on or stripped away from the mass of mycelium/wood chips/sawdust. If the protective plastic is removed and a fog-like environment does not

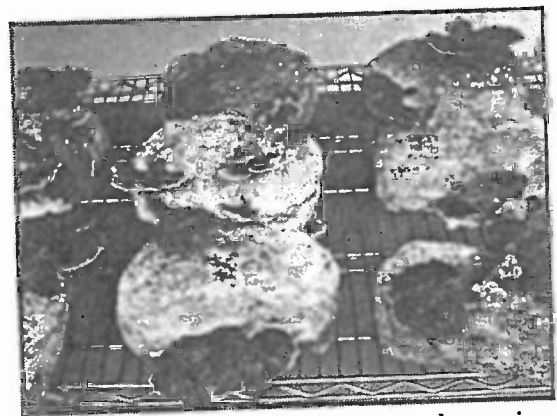
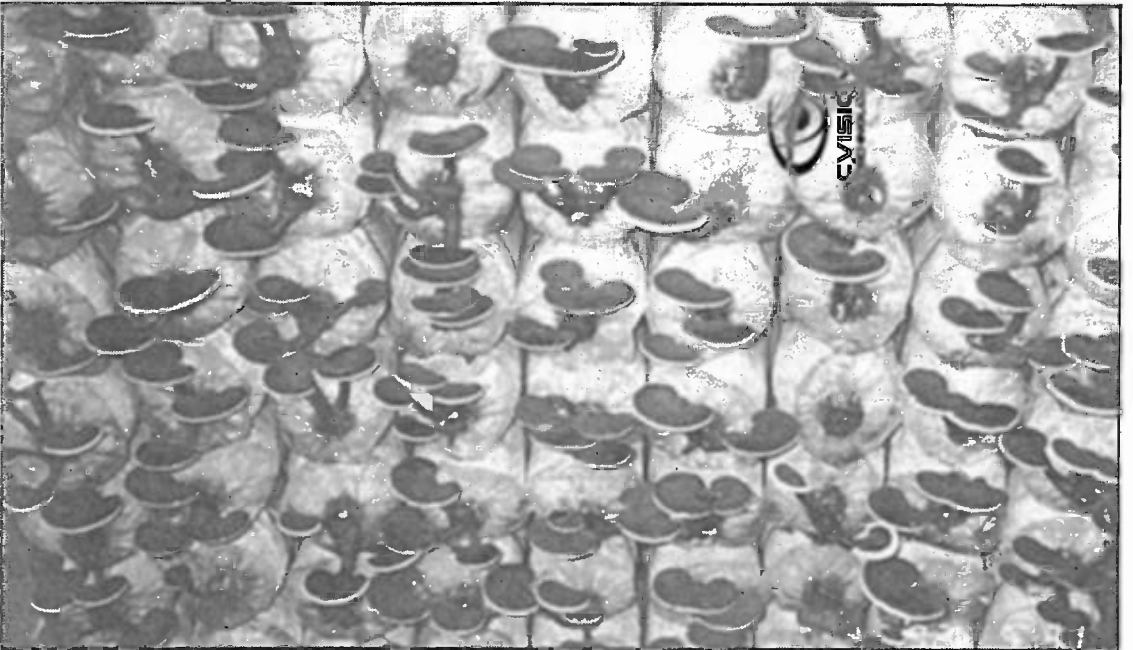
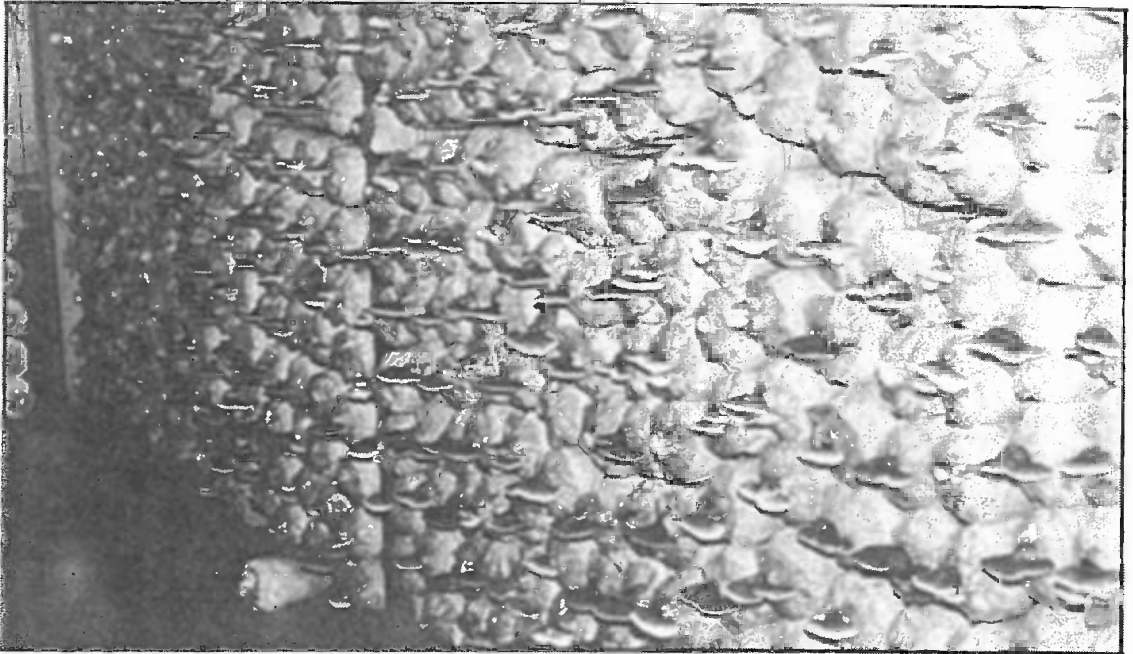
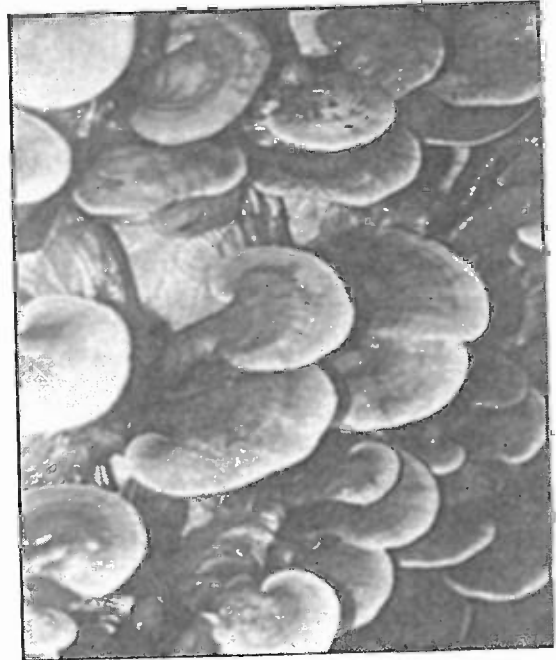
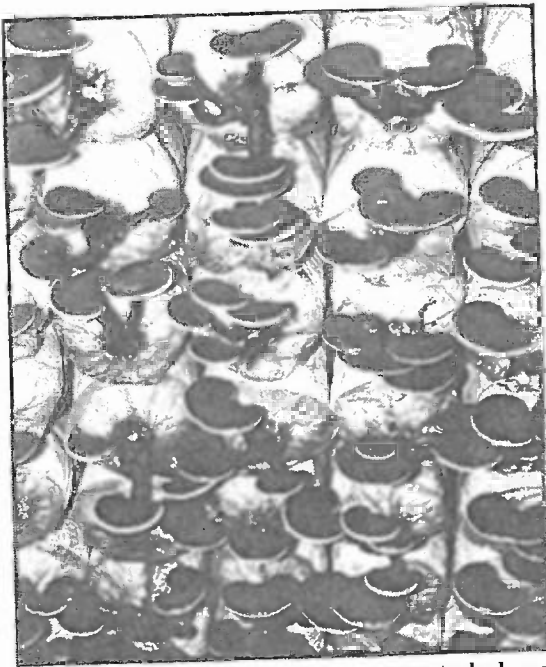

Figure 326. When the plastic is removed, exposing the mycelium, *G. lucidum* will only form when a condensing fog environment is maintained for a prolonged period.



Figures 327–328. In Asia, many cultivators fruit *G. lucidum* through the narrow opening of bags that once hosted the cotton filter plug. The plastic is left intact to help retain resident moisture.



Figures 329 & 330. Cylindrical bags are stacked upon one another to form a Reishi wall.

emerge into the high humidity environment of the growing room. With this method of cultivation, moisture is conserved and channeled to the developing mushrooms. Under low light conditions, stem elongation slows as the mycelium enters into the conk formation period. Cultivators of this method believe that the substantial substrate mass, protected from evaporation, produces better flushes than from a substrate exposed to the open atmosphere. With this second strategy, a condensing fog environment is not as critical as when the substrate is fully exposed to the air. Furthermore, contamination is less likely. Hence growers in Thailand are successful in growing *G. lucidum* in growing rooms featuring gravel floors and equipped with a minimum of environmental controls.

With either rapid cycle method, the cultivator can grow the archetypal form of *Ganoderma lucidum*, one long favored by the Chinese, Japanese, Koreans and Thai peoples. From time of inoculation to time of harvest is less than 3 months. If only antler-shaped fruitbodies form, yields are approximately 1/4 of the yield seen if caps are encouraged to form and mature. Should the cultivator's goals be solely that of yield and the development of the stalk is not desired, then yet another approach is recommended.

Five pounds of moistened hardwood sawdust/chips (60-70% moisture) are filled into the autoclavable, spawn plastic bags. The bags with their tops folded over are loaded into the autoclave and sterilized. After sterilization, approximately 100-150 grams of rye grain spawn is inoculated into the bags subsequent to autoclaving. Each is heat sealed. Colonization is characteristically rapid and complete in 10-20 days. After 30 days, the blocks are removed to the growing room whereupon the plastic is perforated. I use four bladed stainless steel arrowheads mounted on a board. The bags are

## Growth Parameters

### Spawn Run:

Incubation Temperature : 70-80° F. (21-27° C.)  
 Relative Humidity: 95-100%  
 Duration: 10-20 days  
 CO<sub>2</sub>: tolerated up to 50,000 ppm or 5%  
 Fresh Air Exchanges: 0-1  
 Light Requirements: n/a

### Primordia (“Antler”) Formation:

Initiation Temperature: 65-75° F. (18-24° C.)  
 Relative Humidity: 95-100%  
 Duration: 14-28 days  
 CO<sub>2</sub>: 20,000-40,000 ppm  
 Fresh Air Exchanges: 0-1  
 Light Requirements: 4-8 hours at 200-500 lux.

### Primordia (“Young Conk”) Formation:

Temperature: 70-80° F. (21-27° C.)  
 Relative Humidity: 95-100%  
 Duration: 14-28 days  
 CO<sub>2</sub>: 5000-2000 ppm  
 Fresh Air Exchanges: As required for maintaining  
 desired CO<sub>2</sub>  
 Light Requirements: 12 hours on/off at 500-1000 lux.

### Fruitbody Development

Temperature: 70-80° F. (21-27° C.)  
 Relative Humidity: 90-95%  
 Duration: 60 days  
 CO<sub>2</sub>: < 2000 ppm  
 Fresh Air Exchanges: As required  
 Light Requirements: 12 hours on/off 750-1500 lux.

### Cropping Cycle:

Two crops in 90-120 days.

---

never opened. Each one is forcibly slammed downwards into the arrowheads. These “+” shaped slits become the sites for fruitbody formation. The bags are placed in the growing room and harvests of stem-less conks usually begin within a month. See Figure 325.

**Recommended Courses for the Exponential Expansion of Mycelial Mass to Achieve Fruiting:**  
 There are several courses for expanding the mycelium to the fruiting stage. Each step results in an

---



Figure 331. Brown spores, although released from the underside, tend to collect on the upper cap surfaces of *G. lucidum*.

exponential expansion of mycelial mass. The simplest method for most cultivators to follow is similar to the classic spawn expansion schedule employed by most laboratories. The first stage is to grow the mycelium on nutrified agar media in petri dishes. The next is transferring pure cultures onto sterilized grain, typically in jars (quart, half gallons, gallons). At 75° F. (24° C.), two to three weeks pass before colonization is complete. Each of these "Grain Masters" can inoculate 10 gallon jars each containing 1000-1200 grams of sterilized rye grain. Once grown out, each gallon jar of spawn can readily inoculate 10 5 lb. bags of hardwood sawdust (wet weight, 65-70% moisture). The resulting sawdust spawn is the last step before inoculating a substrate capable of supporting fruitbodies.

At this juncture, the cultivator has several options. Four are: to grow fruitbodies on sawdust/chips; to grow fruitbodies on buried logs; to inoculate stumps; or to fruit *Ganoderma lucidum* on vertically arranged columns of heat treated sawdust. (This last method is currently under development by the author.) These four strategies all follow the same expansion schedule from agar-to-grain-to-sawdust-to the production block.

**Suggested Agar Culture Media:** MEA, OMYA, PDYA and/or DFA. Uninhibited by gentamycin sulfate (1/15th gram/liter.)

**1st Generation Spawn Media:** Rye grain, wheat grain, other cereal grains. Fruitbodies do not form on most grains except milo (a type of sorghum), whereupon fans of growth climb the inside surfaces of the spawn containers and fruit within. If mature grain spawn is not used directly after colonization, over-incubation results, making it difficult to disperse the grain kernels upon shaking. In this case, a transfer tool such as a sterilized spoon, knife, or similar tool is needed to break apart the spawn within the jar.

I prefer the liquid inoculation method of generating spawn similar to that described in *The Mushroom Cultivator* by Stamets & Chilton (1983). Further, the mycelium of this species readily adapts to submerged fermentation. Submerged fermentation (liquid culture) of *Ganoderma lucidum* mycelium is considered "traditional" in China.

**2nd & 3rd Generation Spawn Media:** Each unit of primary spawn can be expanded (3 cups grain in 1/2 gallon jar) into 10 (5-20) units of 5 lbs. sterilized, moist sawdust. Once inoculated, and incubated at 75° F. (24° C.) colonization is complete in 8-12 days. The 10 sawdust spawn blocks can be expanded into 100-200 3-5 lbs. sawdust/chip bags, which in turn, are colonized in a similar period of time.

**Natural Method of Cultivation:** Outdoors on buried logs or stumps. Logs or stumps are inoculated via plug or sawdust spawn as described on page 34.

**Fruiting Substrates:** Indoors on hardwood sawdust/chips. 5% supplementation of the sawdust with rice bran or sorghum enhances yields. From my experiences, I have found that over-supplementation with rice bran, beyond 15% of the dry mass of the substrate, inhibits fruitbody development.

**Recommended Containers for Fruiting:** Polypropylene bottles, bags and/or similar containers.

**Yields:** From my experiments, yields on first flush average between 125-200 grams wet mass from 2200-2300 grams wet mass in 30-60 (90) days via the rapid cycle system. (Fruitbodies are 80% water, 10% less in moisture content than fleshier fungi.) Second flushes 25-50% of first. Yields from log/stump culture are approximately 1-2 lbs. per year.

**Harvest Hints:** If polypropylene bags are punctured, a stem-less conk is produced under well lighted, low carbon dioxide conditions. With this strategy, a broad conk snaps off cleanly from a 1/4 inch hole. If stems are encouraged to form by raising carbon dioxide or lowering ambient lighting, the mushrooms can be harvested by first twisting the stem base from the substrate and then trimming debris from the stem base. At 50% rH, mushrooms dry quickly in the open air at room temperature. After the mushrooms have dried, some cultivators short-cycle sterilize their mushrooms by placing them into the autoclave. This heat treatment retards or prevents the birth of any insect larvae from eggs which may have been deposited during mushroom development.

**Form of Product Sold to Market:** Dried, whole mushrooms have been traditionally used in Oriental medicine. However, many other forms are marketed, including in pill, tea, and tincture forms. Ginseng and Ling Chi are often extracted and combined in liquid form by a number of Chinese pharmaceutical collectives. I have also seen cultured mycelium extracted for use in syrups. Antler forms are often preserved as works of art, portrayed in museums or temples, handed down through generations as family heirlooms, and even sold to tourists. (See Figures 315 and 316). Ling Chi is used in beers and wines as a medicinal/flavor additive is also popular in Japan and China.

**Nutritional Content:** Not known.

**Medicinal Properties:** For centuries, the Chinese and Japanese literature has heralded this mushroom for its health invigorating effects, especially attributing it with increasing longevity, treatment of cancer, resistance and recovery from diseases. Himalayan guides have used this mushroom to combat high altitude sickness. Mayan Indians have traditionally employed this mushroom (or a closely related species) in teas to fight a variety of communicable diseases. Reishi has become the natural medicine of choice by North Americans, and has become especially popular amongst immunocompromised groups in recent years.

A complex group of polysaccharides have been isolated from this mushroom which reportedly stimulate the immune system. One theory is that these polysaccharides stimulate helper "T" cell production which attack infected cells. Ganoderic acids have also been isolated from Ling Chi and purportedly have anti-coagulating effects on the blood and lower cholesterol levels. (See Morigawa et al., 1986). Most recently, studies have been published showing its modulating effects on blood

---

pressure and lipid levels (Kabir et al., (1989)), influence on blood glucose levels (Kimura et al., (1989)), and presence of immuno-modulating proteins (Kino et al., (1989)). T. Mizuno summarized the historical development of compounds extracted from this mushroom in *Chemical Times*, (3): 50-60, 1989. (For more information, see Nishitoba et al. (1984), Jifeng et al. (1985), Hirotsani et al. (1985), Sato et al. (1986), Tanaka (1989), and Jong (1991).)

Studies by Stavinoha (1990) on mice at the Texas Health Science Center in San Antonio showed that unextracted "gill powder" (sic) or ether extracts of the mushrooms showed significant anti-inflammatory activity, comparable to hydrocortisone. Weil (1993) noted that it is difficult to reconcile that a mushroom could both be an immune stimulator and an anti-inflammatory agent. His point is that anti-inflammatory agents generally suppress immune function, not enhance it. However, many forms of arthritis are viewed as auto-immune disorders. If the mode of activity of *G. lucidum* is to act as an immuno-modulator, not an immuno-stimulator, then this contradiction in viewpoints is reconcilable.

At the Fifth International Mycological Congress convened in Vancouver, British Columbia, Dr. B.K. Kim et al. (1994) reported that a low molecular weight polysaccharide fraction, isolated from *Ganoderma lucidum*, prolonged the survival of human lymphocytes after exposure to HIV, comparing favorably with healthy cells in terms of longevity. Lymphocytes not treated with this polysaccharide died shortly after exposure to the virus. Clinical studies on are going in Korea. Patents are planned. To my knowledge, no juried reports have been published to date.

According to Willard (1990) who compiled a review of Reishi's properties, this mushroom can cure cancer, chronic fatigue syndrome, liver degeneration, blood disorders and practically every other modern malady to affect human kind. (No wonder Reishi is also known as the "Panacea Polypore"!)

However, to date, no definitive, long-term, double-blind studies with human patients suffering from cancer (or other diseases) have been reported in the English literature. Studies with human patients at the Institute of Materia Medica (Beijing, China) in 1983, showed that Ling Chi had no significant effect against lung cancer after radiation therapy whereas Zhu Ling (*Polyporus umbellatus*) was effective. (Stamets & Weil, 1983).

I have been told by native Chinese that Ling Chi is traditionally given to men by women (or an intermediary messenger) to express sexual interest as Ling Chi purportedly stimulates sexual virility, especially in older men. The antler form is preferred. No medical evidence has been published to support this claim.

**Flavor, Preparation & Cooking:** Typically extracted in hot water for teas, tinctures, syrups, & soups. My family enjoys making a tea from fresh, living specimens, breaking them into pieces, boiling in water for 5 minutes and then steeping for 30 minutes. The tea is reheated to a desired temperature, strained and served, without sweeteners. If a daily regimen of Ling Chi tea is followed, as little as 3-5 grams per person has been traditionally prescribed. The antler forms, with a reduced hymenial package, have a rich, mildly sweet, and soothing flavor reaction. The well developed conk forms reveal a more bitter after-taste. Yellow strains are more often bitter than the red and black strains.



**Comments:** A satisfying mushroom to grow and consume, *Ganoderma lucidum* is a mushroom whose transformations are mesmerizing. Responsive to the slightest changes in the environment, its unique growth habits have undoubtedly enchanted humans for centuries. The formation and development of the fruitbody is greatly affected by the surrounding gaseous environment. Stem growth is elongated under prolonged, elevated carbon dioxide levels (>20,000 ppm) whereas cell formation leading to cap development and hymenial development is activated when carbon dioxide levels fall below 2000 ppm. *Ganoderma lucidum* can be easily grown in a variety of ways, indoors and outdoors. Yield may not be the only measure of this mushroom's value. Although more biomass is generated with a strategy promoting short stalks and large caps, the antler and capitate-antler form appeals to many as art.

As *Ganoderma lucidum* gains popularity with North Americans, feasibility studies on the wide scale cultivation of Reishi on stumps are warranted. If markets could support the resulting yields, a whole new industry might emerge on lands currently providing little or no immediate economic return.

For more information on the taxonomy of this group see Zhao (1989) and Gilbertson & Ryvarden (1987). For general information on the historical and medicinal uses of this fungus, consult Wasson (1972), Jong (1991), Willard (1990), Jones (1992) and Hobbs (1995). For information on the cultivation of *G. lucidum*, see Stamets (1990) and Thaithatgoon et al. (1993).

---

*Grifola frondosa* (Dicks: Fr.) S.F.Gray

Figure 332. *G. frondosa* 4 and 10 days after inoculation onto malt extract agar.

**Common Names:** Maitake ("Dancing Mushroom")\*  
 Kumotake ("Cloud Mushroom")  
 Hen-of-the-Woods  
 The Dancing Butterfly Mushroom

**Taxonomic Synonyms & Considerations:** Synonymous with *Polyporus frondosus* Dicks.: Fr. Closely allied to *Polyporus umbellatus* Fr. (also known as *Grifola umbellata* Pers.: Fr.) which has multiple caps arising from a common stem, a lighter color and a more fragile texture. The primordia of *G. frondosa* are rich, dark gray brown to gray black in color whereas the fruitbody initials of *G. umbellata* are light gray. Macroscopically, these two mushrooms are easily distinguished by their

\*The validity of the common name of Maitake or "Dancing Mushroom" naturally comes into question. According to fable, the ingestion of Maitake caused a group of lost nuns to fall into uncontrolled frenzied dance with a band of woodcutters. The reaction attributed to the Nuns finding this mushroom, their chance encounter with the male woodcutters, and the party-like atmosphere that ensued, seems incongruous with the effects of this mushroom compared to, for instance, the effects of the well known consciousness-raising psilocybian mushroom species like *Gymnopilus spectabilis*, a far more likely candidate. (*G. spectabilis* is known as the Big Laughing Mushroom, or O'warai-take.) The first report of Maitake was recorded in a tale from the 11th century Japanese text Konjaku Monogatari. Imazeki (1973) & Wasson (1973) first cast doubt about the authenticity of "Maitake" being *Grifola frondosa*. Whatever species induced frenzied dance with the nuns and woodcutters, Maitake is today synonymous with *G. frondosa*.

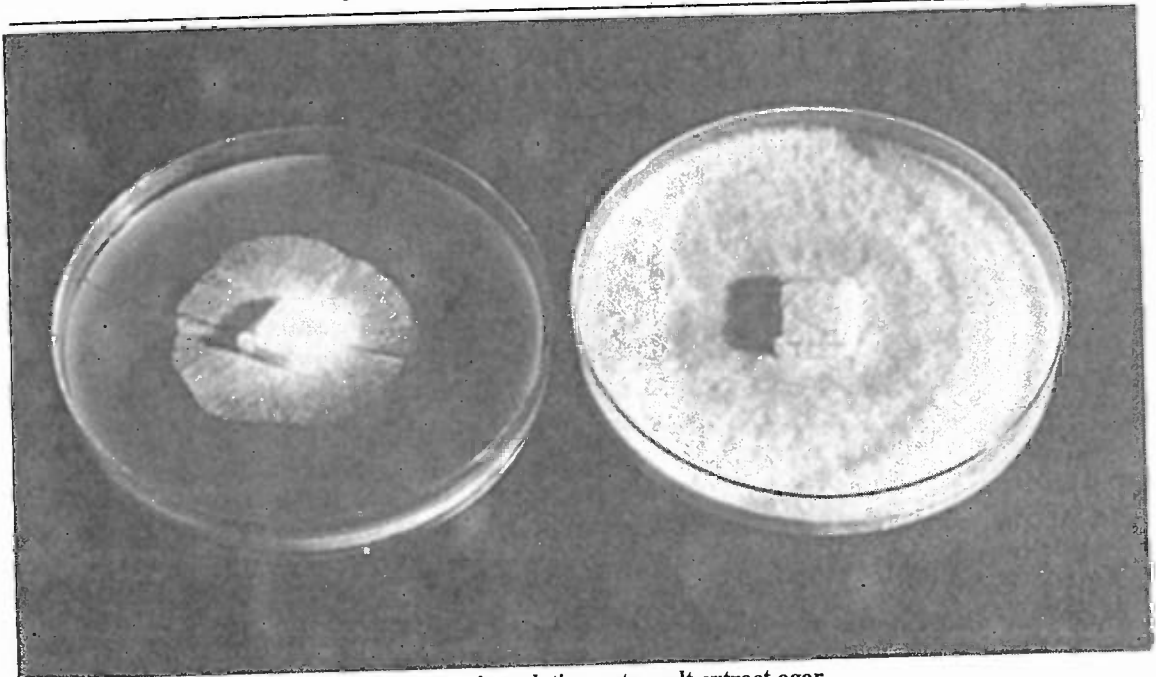

Figure 333. Wild fruiting of Maitake, *G. frondosa*, at base of oak tree.

form. Microscopically, the spores of *G. umbellata* are substantially larger and more cylindrically shaped than the spores of *G. frondosa*.

**Description:** A large, fleshy polypore, dark gray brown when young, becoming lighter gray in age. (Some varieties fade to a light yellow at maturity.) Fruitbody is composed of multiple, overlapping caps, 2-10 cm. in diameter, arising from branching stems, eccentrically attached, and sharing a common base. Young fruitbodies are adorned with fine gray fibrils. The pores on the underside of the caps are white.

**Distribution:** Growing in northern temperate, deciduous forests. In North America, primarily found in Eastern Canada and throughout the Northeastern and Mid-Atlantic states. Rarely found in the northwestern and in the southeastern United States. Also indigenous to the Northeastern regions of Japan, the temperate hardwood regions of China, and Europe where it was first discovered.

**Natural Habitat:** Found on stumps or at the base of dead or dying deciduous hardwoods, especially oaks, elms, maples, blackgum, beech, and occasionally on larch. According to Gilbertson & Ryvarden (1986), this mushroom has also been collected on pines (Douglas fir), although rarely so. *G. frondosa* is a "white rot" fungus. Although found at the bases of dying trees, most mycologists view this mushroom as a saprophyte, exploiting tree tissue dying from other causes.

**Microscopic Features:** Spores white, slightly elliptical (egg-shaped), smooth, hyaline,  $6-7 \times 3.5-5 \mu$ . Hyphal system dimitic, clamp connections present in the generative hyphae, infrequently branching with skeletal, non-septate hyphae.

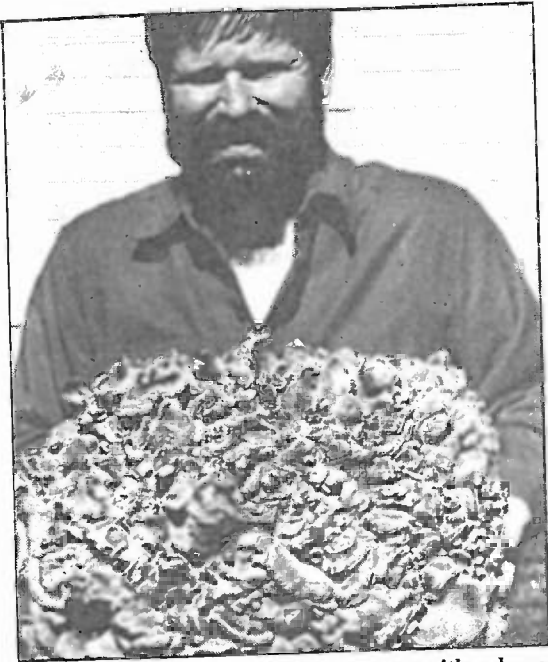

Figure 334. Mycologist Bill Chapman with a huge *Grifola frondosa*, known to Americans as Hen-of-the-Woods and to Japanese as Maitake. This specimen was 5 feet in circumference and estimated to weigh more than 40 lbs. Growing from a stately oak tree in a colonial graveyard in upstate New York, the location of this mushroom patch is a closely guarded secret. This patch consistently produces specimens of such magnitude and occasionally generates 100 lb. clusters.

orangish brown mottled zones, exuding a yellowish orange metabolite. Sawdust spawn, when young, is white. As the spawn matures, rust colors prevail.

**Fragrance Signature:** Richly fungoid and uniquely farinaceous, sometimes sweet. To me, rye grain spawn has a fragrance reminiscent of day-old fried corn tortillas. When mushrooms begin to rot, a strong fish-like odor develops.

**Natural Method of Cultivation:** The inoculation of hardwood stumps or buried logs is recommended. Given the size of the fruitbody, its gourmet and medicinal properties, this mushroom may well become the premier species for recycling stumps in hardwood forests. The occurrence of this mushroom on pines, Douglas fir, and larch is curious, confirming that some strains exist in nature that could help recycle the millions of stumps dotting the timberlands of North America. As forests decline from acid rain, future-oriented foresters would be wise to explore strategies whereby the dead trees could be inoculated and saprophytized by Maitake and similar immuno-poten-

**Available Strains:** Strains from the wild, unlike those of *Pleurotus*, rarely produce under artificial conditions. Of the strains I have tested which have been obtained from culture libraries, deposited there by taxonomically schooled, non-cultivator mycologists, 90% of them do not fruit well on sterilized wood-based substrates. Therefore, screening and development of strains is necessary before commercial cultivation is feasible. Strains which produce fruitbody initials in 30 days are considered very fast. Most strains require 60-120 days of incubation before primordia formation begins.

**Mycelial Characteristics:** White, longitudinally linear, eventually thickly cottony on enriched agar media, non-rhizomorphic. The mycelium grows out unevenly, not forming the circular colonies typical of most mushrooms. Regions of the mycelium surge while other regions abate in their rate of growth. This pattern of growth seems characteristic of the species, as I have seen it in the majority of the 20 strains of *G. frondosa* that I have in my culture library. Often times, the mycelium develops light tawny brown tones along the outside peripheral edges in aging. At maturity, the dense mycelial mat can be peeled directly off the agar media. Once on sawdust, many strains have mycelia which develop strong yellowish to



Figure 335. Maitake usually fruits at the base of dead or dying trees. This is the same tree that yielded the 40 lb. cluster in Figure 328. Some clusters have weighed in at 100 lbs. apiece.

tiating fungi in the 21st century.

Those experimenting with stump culture should allow one to three years before fruitings can be expected. High inoculation rates are recommended. Stumps do not necessarily have to be “virgin”. Maitake is well known for attacking trees already being parasitized by other fungi, as does Zhu Ling (*Polyporus umbellatus*). However, it is not yet known under what conditions, Maitake will dominate over other fungi in this situation. Therefore, for best results, the inoculation of recently made stumps is recommended.

As the anti-HIV and immuno-potentiating properties of Maitake become better understood, I envision the establishment of *Sacred Medicinal Mushroom Forests & Gardens* in the near future. Permaculturally oriented farms could inoculate hardwood stumps interspersed amongst multi-canopied shade trees. (See Chapter 5.) Clear economic, ecological, medicinal and moral incentives are in place for such Maitake models. Those with compromised immune systems would be wise to establish their

own medicinal mushroom patches utilizing Maitake and other mushrooms.

**Recommended Courses for Expansion of Mycelial Mass to Achieve Fruiting:** Agar to cereal grain (rye, wheat, sorghum, milo) for the generation of Spawn Masters. These can be expanded by a factor of 10 to create 2nd Generation grain spawn. This spawn can, in turn, be used to inoculate sawdust. The resulting sawdust spawn can either inoculate stumps outdoors, or for indoor cultivation on sterilized sawdust/chips/bran.

Most fruiting strains begin producing 6-8 weeks from inoculation onto sterilized, supplemented sawdust. Chung and Joo (1989) found that a mixture 15:5:2 of oak sawdust:poplar sawdust:corn waste generated the greatest yields. The Mori Mushroom Institute of Japan has successfully used larch sawdust, supplemented with rice bran, to grow this mushroom. As a starting formula, I recommend using the standard sawdust:chips:bran combination described for the cultivation of Shiitake and then amending this formula to optimize yields. If blocks of this substrate formula are mixed to a make-up weight of 5lbs. and then inoculated with 1/2 lb. of grain spawn, 1/2-1 lb. clusters of Maitake can be expected. However, by increasing the makeup weight to 7 lbs., Maitake clusters greater than 1 lb. are generated. The only draw-back is that through-spawning is made more difficult using the standard bags available to the mushroom industry. With an increase in substrate mass, elevated

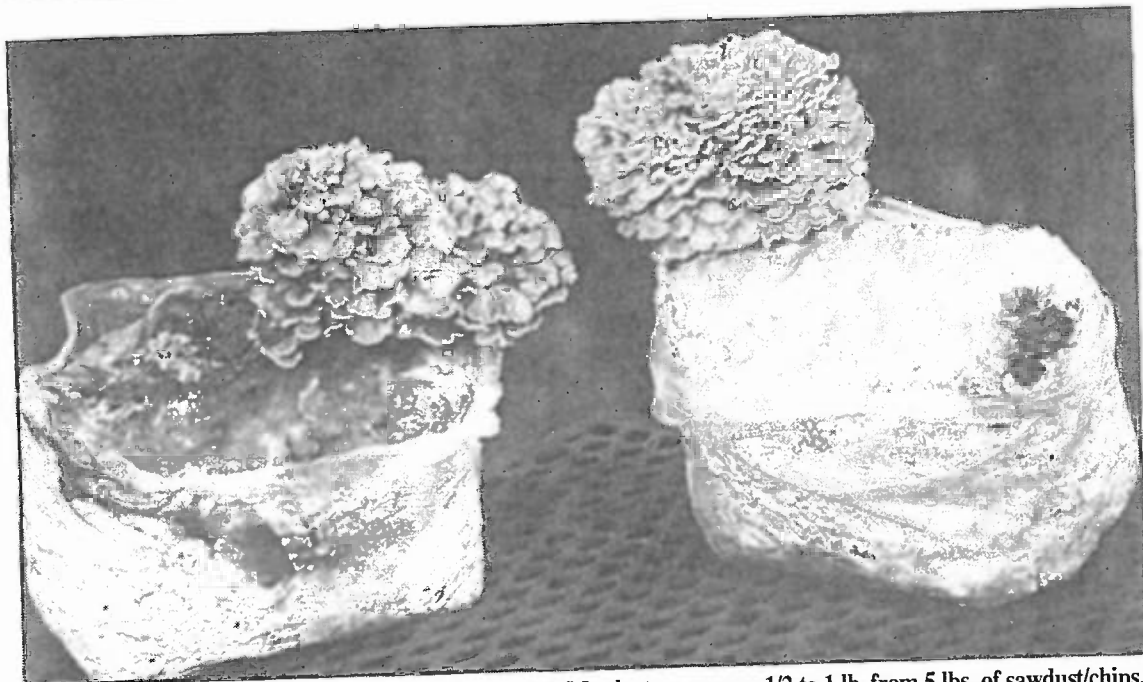

Figure 336. Fully developed Maitake ready for harvest. My clusters average 1/2 to 1 lb. from 5 lbs. of sawdust/chips.

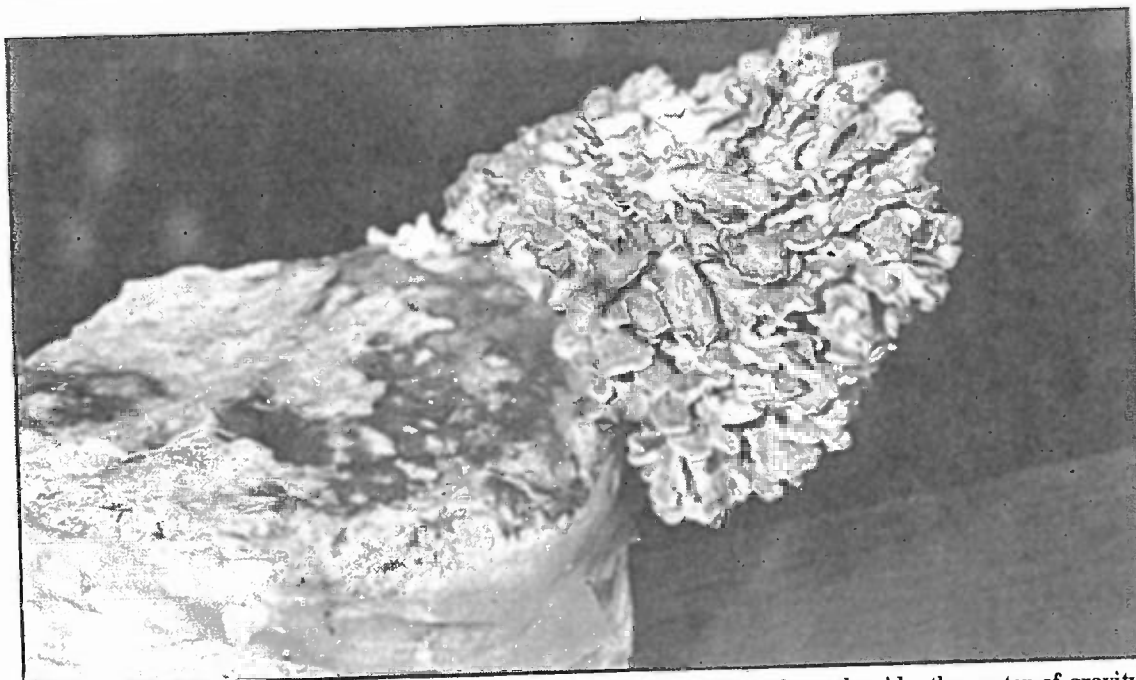

Figure 337. 1 lb. cluster at ideal stage for picking. When Maitake grows from the side, the center of gravity moves as the mushroom matures, sometimes causing the block to fall over.

## Growth Parameters

### Spawn Run:

Incubation Temperature: 70-75° F. (21-24° C.).  
Relative Humidity: 95-100%  
Duration: 14-30 days, then dormant for 30 days.  
CO<sub>2</sub>: 20,000-40,000 ppm  
Fresh Air Exchanges: 0-1  
Light Requirements: n/a

### Primordia Formation:

Initiation Temperature: 50-60° F. (10-15.6° C.)  
Relative Humidity: 95%  
Duration: 5-10 days  
CO<sub>2</sub>: 2000 - 5000 ppm  
Fresh Air Exchanges: 4-8  
Light Requirements: 100-500 lux.

### Antler or "Stem" Development:

Temperature: 50-60° F. (10-15.6° C.)  
Relative Humidity: 95%  
Duration: 10-14 days  
CO<sub>2</sub>: 2000 - 5000 ppm  
Fresh Air Exchanges: 4-8  
Light Requirements: 100-500 lux.

### Fruitbody Development:

Temperature: 55-60° (65°) F. (13-16° (18°) C.)  
Relative Humidity: 85-90%  
Duration: 14 - 21 days  
CO<sub>2</sub>: < 1000 ppm  
Fresh Air Exchanges: 4-8  
Light Requirements: 500-1000 lux

### Cropping Cycle:

Every 3-4 weeks for a maximum of two flushes.

---

thermogenesis is to be expected. Therefore, using sawdust spawn to inoculate bags of greater mass is recommended for more thorough colonization with less evolution of heat in contrast to using grain spawn. Variation between strains' performances on various woods is considerable. Cultivators must fine tune their substrate formulas to each strain.

---

**Suggested Agar Culture Media:** MYA, MYPA, PDYA or DFA.

**1st, 2nd & 3rd Generation Spawn Media:**

Grain-to-grain expansions. The final spawn medium can be another generation of grain spawn, or alternatively sawdust. The sawdust spawn can be used to inoculate supplemented sawdust (i.e. sawdust/chips/bran) or plugs for outdoor cultivation on stumps or partially buried, vertically positioned, large diameter hardwood logs. Considering the long incubation period, cultivators are well advised to weigh the advantages of creating another generation of sawdust spawn. The advantage of the grain spawn-inoculated bags is that they produce several weeks earlier than do the sawdust-inoculated blocks. However, the quality of colonization is better provided by spawn made of sawdust than from grain.

**Substrates for Fruiting:** Supplemented hardwood sawdust, particularly oak, poplar, cottonwood, elm, willow and alder. Alder and poplar stumps are less likely to support outdoor fruitings, given the hold competitors like *Pleurotus ostreatus* and allies have on that niche. For indoor cultivation, yields vary substantially between various wood types. Oak is generally preferred, although strains growing on conifers are being developed.

**Recommended Containers for Fruiting:** Polypropylene bags with filter patches for air exchange. Polypropylene bottles and buckets have also been used.

**Yield Potentials:** 1/2 to 2lbs. mushroom per 5-7 lbs. of sterilized, enriched hardwood sawdust.

**Harvest Hints:** Relative humidity should be carefully lowered as the fruitbody develops to prevent bacterial blotch. Over-watering can quickly cause the fruitbodies to abort. The thick base should be cut to remove substrate debris. Mushrooms wrapped in rice paper, and then refrigerated, have an extended shelf life up to two weeks at 35° F. (1-2.° C.)

**Form of Product Sold to Market:** Fresh and dried mushrooms for the gourmet market. High quality tablets are being marketed in the United States by Maitake, Inc. Fungi Perfecti is currently selling a tea ("Stamets Olympic Rainforest Mushroom Tea") containing dried fruitbodies of this mushroom. (For the addresses of these two companies, please refer to the Resource section on page 495.) Fresh Maitake has been inexpensive and commonly available throughout the food markets of Japan. In

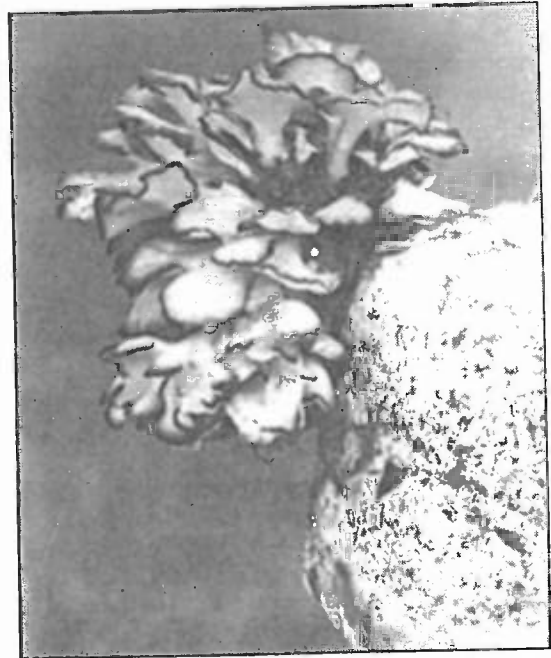

**Figure 338.** Maitake at the perfect stage for harvest—when the leaflets fully extend. When Maitake spoils, the tissue from which these leaflets arise becomes soft to the touch and emits a foul odor from the proliferation of bacteria.



1992, dried Maitake from Japan was fetching between \$600 - \$ 1200 per dry pound when sold to the medicinal mushroom market. Availability of this mushroom is expected to fluctuate wildly as demand surges in response to its rapidly increasing medicinal reputation.

**Nutritional Content:** Approximately 27% protein (dry weight). Producing assorted vitamins - Vitamin B1: 1.5 mg%; Vitamin B2: 1.6 mg%; Niacin: 54 mg%; Vitamin C: 63 mg%; and Vitamin D: 410 IU. Saccharide content is nearly 50%. Assorted minerals/metals include: Magnesium at 67 mg%; Iron at 0.5 mg%; Calcium at 11.0 mg%; and Phosphorus at 425 mg%. Moisture content of fresh specimens are approximately 80%, in contrast to more fleshy mushrooms which average 90% water.

**Medicinal Properties:** Recent, *in vitro* studies at the National Cancer Institute of the powdered fruitbodies (sulfated fraction) of *Grifola frondosa* show significant activity against the HIV (AIDS) virus when tested through its Anti-HIV Drug Testing System under the Developmental Therapeutics Program. The National Institute of Health of Japan announced similar results in January of 1991. (The mycelium is not active.) Maitake extracts compared favorably with AZT but with no negative side effects. This is the first mushroom confirmed to have anti-HIV activity, *in vitro*, by both US and Japanese researchers. U.S. scientists, using similar screening techniques, have not been able to confirm the anti-HIV effects of Shiitake and Reishi. Studies with human subjects are currently ongoing in United States, Sweden and England. *As promising as these preliminary studies are, optimism must be held in check until human studies confirm activity.*

One of the polysaccharide fractions responsible for the immunostimulatory activity is three branched  $\beta$ 1.6 Glucan, known as grifolan. This polysaccharide was first characterized by Ohno et al.



Figure 339. Maitake fruiting in Japan from blocks that were buried outside in soil months before.

(1985), whose team found it in both the mycelium and the mushrooms. Their work showed strong anti-tumor activity in mice against murine solid tumor, Sarcoma-180 in only 35 days, causing complete tumor regression in 1/3 to 1/2 of the trials. Alkali extracts were found to be more effective than cold or hot water infusions.

According to Chinese and Japanese reports, water extracts of this mushroom, when given to mice implanted with tumors, inhibited tumor growth by more than 86%. (Nanba (1992); Ying et al., (1987)). The dosage level was 1.0-10 milligrams of Maitake extract per kilogram of body weight over ten days. No studies have yet been published in ascertaining the extrapolation of this dosage level from a mouse to a human. Dr. Fukumi Morishige suggests that vitamin C be taken with Maitake (as well as with *Ganoderma lucidum*) as it helps reduce the polysaccharides into smaller, more usable chains of sugars, increasing their bio-availability.

A protein-bound polysaccharide (D-fraction) is particularly effective via oral administration. How these polysaccharides activate the mammalian immune system is unknown. However, an increase in helper "T" cells has been seen with some AIDS patients. With other AIDS patients, the decline in helper "T" cells is interrupted. Much more research will be published in the next few years.

Other medicinal claims for this mushroom include: reduction of blood pressure, diabetes, cholesterol, chronic fatigue syndrome (CFS), and a wide variety of cancers.

For further information concerning the medicinal properties of this mushroom, refer to Adachi et al. (1987); Kabir & Yamaguchi (1987); Adachi et al., (1988), Hishida (1988); Yamada et al. (1990), Nanba (1992), and Kubo et al. (1994). Also see *Chemical Pharmacological Bulletin* 35(1) 1987 and *Japan Economic Journal* (May, 1992). Articles in the popular press include *Asahi Evening News*, (March 12, 1993), and *Natural Health* (May, 1993).

**Flavor, Preparation & Cooking:** Towards the stem base, the flesh of this mushroom is thick and dense, and is better sliced. The upper petal-like caps are better chopped. This mushroom can be prepared in many ways, delighting the connoisseur mycophagist. Simply slicing and sautéing *a la Shiitake* is simple and straight-forward. This mushroom can also be baked and stuffed with shrimp, sliced almonds, spices, and topped with melted cheese. The late Jim Roberts of Lambert Spawn once fed me this dish featuring a 1 lb. specimen which I devoured at one sitting, making for a very satisfying meal and a sleepful night. Dried specimens can be powdered and used to make a refreshing tea. Refer to the recipes in Chapter 24 which describes several methods for preparing Maitake.

**Comments** This species is delicious and much sought-after. Specimens weighing up to 100 lbs. have been collected at the base of trees, snags, or stumps. Although primarily a saprophyte, *G. frondosa* behaves facultatively as a parasite, attacking trees dying from other causes, especially elms and oaks.

From my experiences, only a few strains isolated from the wild perform under artificial conditions. Those which do fruit, mature best if the environment is held constant between 55-60° F. (13-16 C). Substantial fluctuation beyond this temperature range arrests fruitbody development. The best fruitings are those which form slowly and are localized from one or two sites of primordia formation. When Maitake is incubated outside the ideal temperature range, the fruitbody initials fail to further differentiate. Should the entire surface of the block be encouraged to form primordia, an aborted plateau of short folds results.

*Fruitbody development passes through four distinct phases.* During initiation, the mycelium first undergoes a rapid discoloration from white undifferentiated mycelium to a dark gray amorphous mass on the exposed surface of the fully colonized block. During the second phase, the surface topography soon becomes contoured with dark gray black mounds which differentiate into ball-like structures. The third phase begins when portions of this primordia ball shoot out multiple stems topped with globular structures. Each globular structure further differentiates with vertically oriented ridges or folds. The fourth and final phase begins when, from this primordial mass, a portion of the folds elongate into the petal-like sporulating fronds or "leaflets". With some strains and under some conditions, the third phase is skipped.

The strategy for the successful cultivation of Maitake is in diametric opposition to the cultivation of Oyster mushrooms. If Maitake is exposed to substantial and prolonged light during the primordia formation period, the spore-producing hymenophore is triggered into production. This results in dome shaped primordial masses, devoid of stems. If, however, minimal light is given, and carbon dioxide levels remain above 5000 ppm, stem formation is encouraged. (Elongated stem formation with Oyster cultivation is generally considered undesirable.) Once the stems have branched and elongated to two or more inches, carbon dioxide levels are lowered, light levels are increased, signalling Maitake to produce the sporulating, petal-shaped caps. Humidity must be fluctuated between 80-95%. Maitake, being a polypore, enjoys less humid environments than the fleshier, gilled mushrooms.

If growing in polypropylene bags, the bags should be opened narrowly at the top so that a forking bouquet is elicited. Stripping off all the plastic increases evaporation from the exposed surfaces of the block, jeopardizing the moisture bank needed for successful fruitbody development. In my growing rooms, I follow a compromise strategy. Given good environmental controls and management, I am successful at growing Maitake by fully exposing the upper surface of the mycelium once the gray primordial mounds have formed 45-60 days after inoculation I leave the remainder of the plastic around the block to ameliorate the loss of water. Holes are punched in the bottom of the bags for drainage.

As the mushrooms develop, less watering is needed in comparison to that needed by, for instance, Oyster mushrooms. Furthermore, cultivators should note that if too much base nutrition of the substrate is allocated to stem formation, the caps often abort. And, if the sawdust is over-supplemented, bacteria blotch is triggered by the slightest exposure to excessive watering or humidity. Every strain behaves differently in this regard. Maitake cultivation requires greater attention to detail than most other mushrooms. Because of its unique environmental requirements, this mushroom can not share the same growing room as many of the fleshier gourmet and medicinal mushrooms.

Once the production blocks cease producing, they can be buried outside in hardwood sawdust and/or soil. In outdoor environments, the subterranean block becomes a platform for more fruitings, maximizing yield. Blocks planted in the spring often give rise to fruitings in the fall. (See Figure 339). The autoclavable, plastic should be removed—unless made of cellulose or other biodegradable material. By scratching the outer surfaces of the blocks, the internal mycelium comes into direct contact with the sawdust bedding, stimulating leap-off.

*Polyporus umbellatus* Fries

Figure 340. *P. umbellatus* mycelia 4 and 10 days after inoculation onto malt extract agar media.

**Introduction:** This fleshy polypore has long been a favorite edible. Of all the species represented in the Genus *Polyporus*, *P. umbellatus* is the most fragile and delicate. This mushroom forms an underground tuber-like structure, a sclerotium, which has figured prominently in Chinese pharmacopeia, especially in the treatment of lung cancer.

**Common Names:** Zhu Ling (Chinese for "Hog Tuber")  
 Chorei-maitake (Japanese for "Wild Boar's  
 Dung Maitake")  
 Tsuchi-maitake (Japanese for "Earth Maitake")  
 Umbrella Polypore  
 Chinese Sclerotium

**Taxonomic Synonyms & Considerations:** Gilbertson and Ryvardeen (1987) follow tradition by keeping this mushroom within the Genus *Polyporus*, i.e. *Polyporus umbellatus* Fr. This mushroom is commonly referred to as *Grifola umbellata* (Persoon: Fries) Donk and more infrequently called *Dendropolyporus umbellatus* (Pers.:Fr.) Julich.

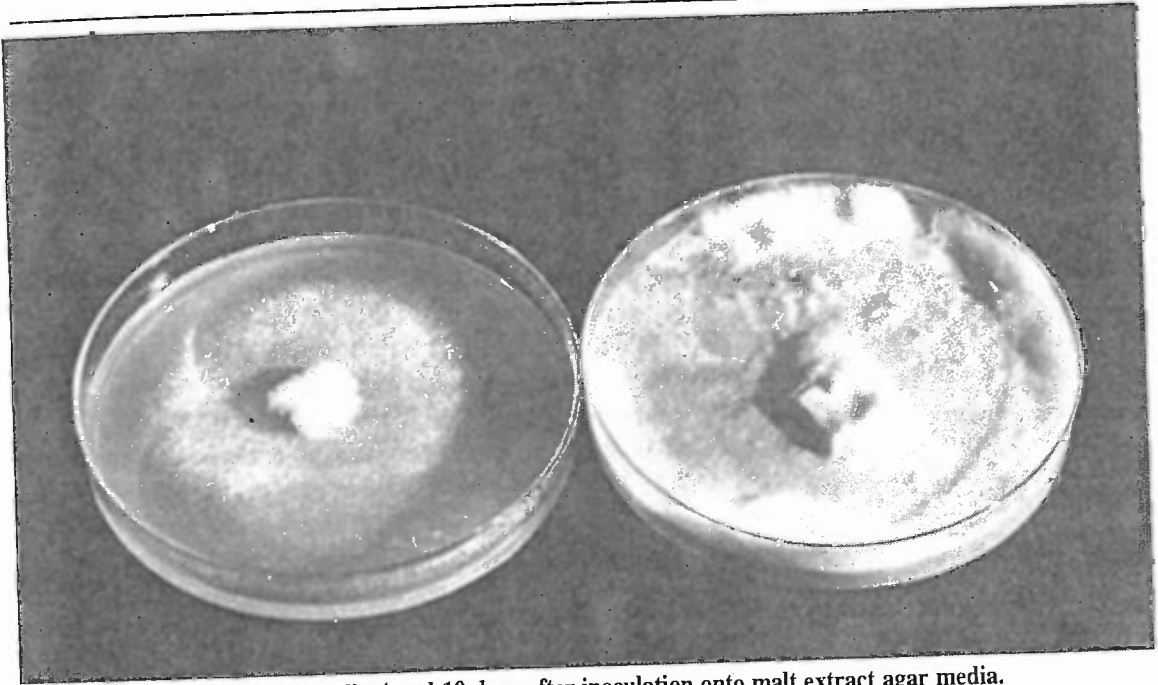
Macroscopically *Grifola frondosa*, Maitake, appears to be a close relative, but biologically the two have uniquely different life cycles. The close appearance of *P. umbellatus* and *G. frondosa* easily con-

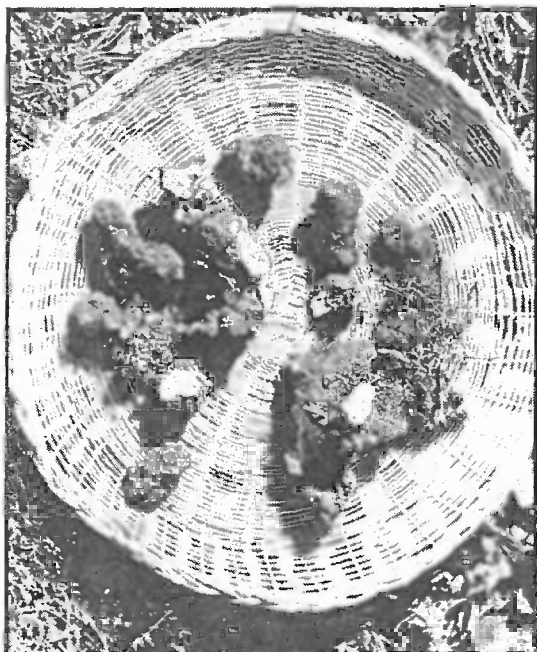

Figure 341. Sclerotia of North American *P. umbellatus*.

fuses amateur collectors. (Lincoff (1993)). *G. frondosa* has smaller, non-cylindrical spores, lacks the sclerotial stage in its life cycle, and arises from a multiple forking base.

**Description:** The mushrooms arise from underground sclerotia. The near black sclerotium, resembling pig's dung in form, but woody in texture, swells with water and generates a multi-branched, circular shaped mushrooms with umbellicate caps. These bouquets of mushrooms arise from a common stem base. The fruitbodies are whitish at first, becoming dingy brown with age, with an underside featuring circular to angular pores.

**Distribution:** Infrequently occurring throughout the deciduous woodlands of north-central and northeastern North America, in the temperate regions of China, and in Europe where it was first described. Gilbertson & Ryvardeen (1987) reported this mushroom from the states of Montana and Washington. If this mushroom in-

deed grows in the Pacific Northwest, it is exceedingly rare, as I have never found it, and know no one who has.

**Natural Habitat:** Found on the ground, arising from dead roots or buried wood, on stumps, or in soils rich in lignicolous matter, preferring birches, maples, willows, and beeches. Predominantly growing in deciduous woodlands, this mushroom has been reported from coniferous forests, although rare. Weir (1917) reported this mushroom from Montana growing on spruce (*Picea* sp.).

**Microscopic Features:** Spores 7-10 x 3-4  $\mu$ , white in deposit, smooth, cylindrical. Hyphal system dimitic, non-septate, clamp connections present on the generative hyphae.

**Available Strains:** Strains are available from most culture libraries. However, most of the strains that I have tested are non-fruiting in culture. Hence, strains which can produce under indoor, controlled conditions are needed.

**Mycelial Characteristics:** White, longitudinally linear, soon densely cottony, forming a thick, peelable mycelial mat on agar, grain, and in sawdust media. On sterilized sawdust, the mycelium, as it ages, forms outer layers of yellowish, gelatinous exudate. This mushroom causes a white rot.

**Fragrance Signature:** Musty, sour, slightly bitter, not pleasant.

**Natural Method of Cultivation:** The roots of stumps are inoculated by digging trenches into the root zones which have been already parasitized by, for instance, the Honey Mushroom, *Armillaria mellea*.



Figure 342. A soft, delicate, fleshy fruitbody arises from a sclerotium.

can be grown via two methods: from a sclerotium or directly from the mycelial mat by-passing the sclerotial stage. Sclerotial production is stimulated by the microflora in soils, and by the absence of light. Therefore formation of sclerotia under laboratory conditions is difficult. However, there is an alternative strategy.

Zhu Ling behaves as a secondary saprophyte, depending upon the degradative abilities of other fungi to render a wood substrate into usable platform for fruiting. In my experiments, fruitings did not result when the same formula was prepared from fresh starting material (i.e. sawdust/chips/bran). I have had limited success at fruiting this species on the remains of sterilized, recycled Shiitake and Reishi blocks. Nevertheless 45-60 days of incubation preceded any mushroom formation. This method has only resulted in short, lateral, hardened plateaus with pored surfaces, which achieved only a few centimeters in height. The pores contained sporulating basidia. This abbreviated fruitbody formation may be a function of an insufficiently developed sclerotial stage. Sclerotia store nutrition prior to fruitbody initiation. More research is required before indoor cultivation yields fruitings comparable to other Polypores like Reishi or Maitake.

**Suggested Agar Culture Media:** MYPA, PDYA, OMYA or DFA.

**1st, 2nd & 3rd Generation Spawn Media:** Two expansions of grain spawn with the final spawn stage being sawdust.

**Substrates for Fruiting:** Outdoor plantings require the placement of either spawn or sclerotia into

Logs of beech, birch, willow, maples and/or oaks are given multiple cuts into which sawdust spawn or slices of fresh sclerotia are packed. The logs are re-buried underneath a layer of sandy soil and covered with rich humus and deciduous leaves. After three years, the trenched logs are unburied and new sclerotia can be harvested. For sclerotia harvest, late spring is best. Fruitbodies are generated from the sclerotia in the late summer to early fall, when the ground temperature hovers between 50-60° F. (10-15° C.). For more information, consult *Fungi Sinica*, 1980. (See Figure 343.)

**Recommended Courses for Expansion of Mycelial Mass to Achieve Fruiting:** Liquid culture to grain to sawdust to supplemented sawdust/chips. The cultivation of this mushroom initially parallels that of Maitake, *Grifola frondosa*, another fleshy polypore, according to Jong (1992). My own successes with this mushroom have been limited. *G. umbellata*

## Growth Parameters

### Spawn Run:

Incubation Temperature: 60-75° F. (15-24° C.)  
 Relative Humidity: 90-100%  
 Duration: 21-30 days to 2 years  
 CO<sub>2</sub>: > 5000 ppm.  
 Fresh Air Exchanges: 1-4  
 Light Requirements: n/a

### Sclerotia Formation:

Incubation Temperature: 50-60° F. (10-16° C.)  
 Relative Humidity: 90-100%  
 Duration: 60 - 90 days  
 CO<sub>2</sub>: > 5000 ppm.  
 Fresh Air Exchanges: 1-4  
 Light Requirements: darkness required

### Primordia Formation:

Initiation Temperature: 40-50° F. (4-10° C.)  
 Relative Humidity: 90-100%  
 Duration: 30-60 days  
 CO<sub>2</sub>: < 5000 ppm  
 Fresh Air Exchanges: 8 or more  
 Light Requirements: modest to low light, no greater 200 lux.

### Fruitbody Development:

Temperature: 50-60° F. (10-16° C.)  
 Relative Humidity: 85-95%  
 Duration: 30-90 days.  
 CO<sub>2</sub>: < 500 ppm or ambient natural  
 Fresh Air Exchanges: 4-8+ per hour  
 Light Requirements: 500-1000 lux.

### Cropping Cycle:

Seasonal, typically occurring in the late summer and early fall.

---

logs buried into beds of hardwood sawdust, around the root zones of beeches, birches, willows or oaks. For indoor cultivation, I have had limited success using hardwood sawdust substrates rendered by other primary saprophytes. Expired Shiitake, Maitake and Reishi blocks seem to work the best. I recommend cultivators experiment growing sclerotia on recycled substrates in darkness, removing the sclerotia when mature, and implanting them in lignicolous soils to stimulate fruitings. Currently the modified natural model is the main method of cultivation in China.

---

**Recommended Containers for Fruiting:** Polypropylene bags for indoor cultivation. Trench culture outdoors can be framed with non-chemically treated boards around the root zones of candidate trees and protected with shade clothed, covered hoop-frames.

**Yield Potentials:** Not known. The natural model developed by the Chinese first yields sclerotia as the primary product, and secondarily mushrooms which are more often used for food than for medicinal purposes. In liquid culture, I have achieved a 6% yield (d.w./d.w.) of dry mycelium from a malt yeast slurry. Yield efficiencies of sclerotia and mushrooms from Chinese Zhu Ling tree nurseries (a.k.a. "Hog Tuber Farms") are not known to this author.

**Form of Product Sold to Market:** Sclerotia are exported from China, either whole or sliced, and in dried form. (Packages of Zhu Ling often have a picture of Reishi on the label!) The fresh fruitbodies are sold in markets in China. Currently, there are no producers of this mushroom in North America.

**Nutritional Content:** Protein: 8%; coarse fiber: 47%; carbohydrate: .5%; and ash: 7%. The sclerotia, with its woody texture, is likely to have substantially more polysaccharides and less protein than the fleshy fruitbody.

**Medicinal Properties:** This mushroom has been heralded to possess potent anti-cancer, immunopotentiating properties. However, few scientific studies have been conducted, and none by Western researchers. During a visit to the Beijing Institute of Materia Medica in October of 1983, Dr. Andrew Weil, Dr. Emanuel Salzman, Gary Lincoff and myself were informed by excited researchers that water extracts (tea) of this mushroom, when given to lung cancer patients after radiation therapy, resulted in complete recovery in the majority of the patients after several years. The quality of life of the patients dramatically improved, characterized by increased appetites, absence of malaise, etc. The majority of those patients not given Zhu Ling died. I do not know if this study was ever published.

In a separate study, Chang Jung-lieh (1983) presented results on the strong inhibitory effects Zhu Ling had on sarcoma 180 tumors implanted in mice. Taken orally or intravenously, Zhu Ling has been widely used as a traditional drug for preventing the spread of lung cancer. Modern day treatments using Zhu Ling often accompany radiation therapy. A juried paper, presented by Han (1988) in the *Journal of Ethnopharmacology*, reported that mice, when implanted with sarcoma 180 were given a dose of 1 mg. of Zhu Ling per kilogram of body weight, tumors were reduced by 50% compared to the controls. Ying (1987) reported 70% reduction of tumor weight in mice. Miyaski (1983) also noted the anti-sarcoma properties of this fungus. Dr. Andrew Weil (1992) strongly believes this species deserves greater attention by Western medical practitioners. I have sent specimens (sclerotia) to the U.S. National Cancer Institute for testing in their AIDS and cancer screening programs and, at the time of this writing, am awaiting results. They have expressed extreme interest in all higher fungi which undergo a sclerotial stage.

According to Bo & Yun-sun (1980, pp.195), Chinese physicians are using extracts of the Zhu Ling sclerotia in the treatment of "lung cancer, cervix cancer, esophagus cancer, gastric cancer, liver cancer, intestine cancer, leukemia, mammary gland cancer and lymphosarcoma."

**Flavor, Preparation & Cooking:** The fleshy, above-ground mushroom is easily broken or chopped,

---



placed into a frying pan or wok, and sauteed as one would do with Shiitake.

The sclerotia are usually made into a tea by placing 20-25 grams in a liter of water and boiling for 20 minutes. Additional water is added to offset that lost to evaporation. Since the sclerotia are extremely tough, and are difficult to extract, I leave the sclerotia chips in the water for several more soakings before discarding. It should be noted that I have made tea of Zhu Ling & Reishi for more than 1000 people at various mushroom conferences over the past 7 years without a single report of a negative reaction.

**Comments** Zhu Ling sclerotia remain some of the least expensive of the imported medicinal fungi. Grown quasi-naturally in the temperate, mountainous Shansi Guu County of China, the sclerotia sell for about 1/2 the price of Reishi. Once the anti-cancer properties of this fungus become better understood, and if proven, the value of Zhu Ling sclerotia is likely to increase.

The sclerotia are used medicinally whereas the fleshy and fragile fruitbodies, known as “Hog Tuber Flowers” are eaten as a gourmet mushroom. This is one of the softest Polypores I have encountered. Its excellent flavor, unique life cycle, medicinal properties and scarcity are all factors that should encourage the development of indoor, controlled environment fruitings by cultivator entrepreneurs.

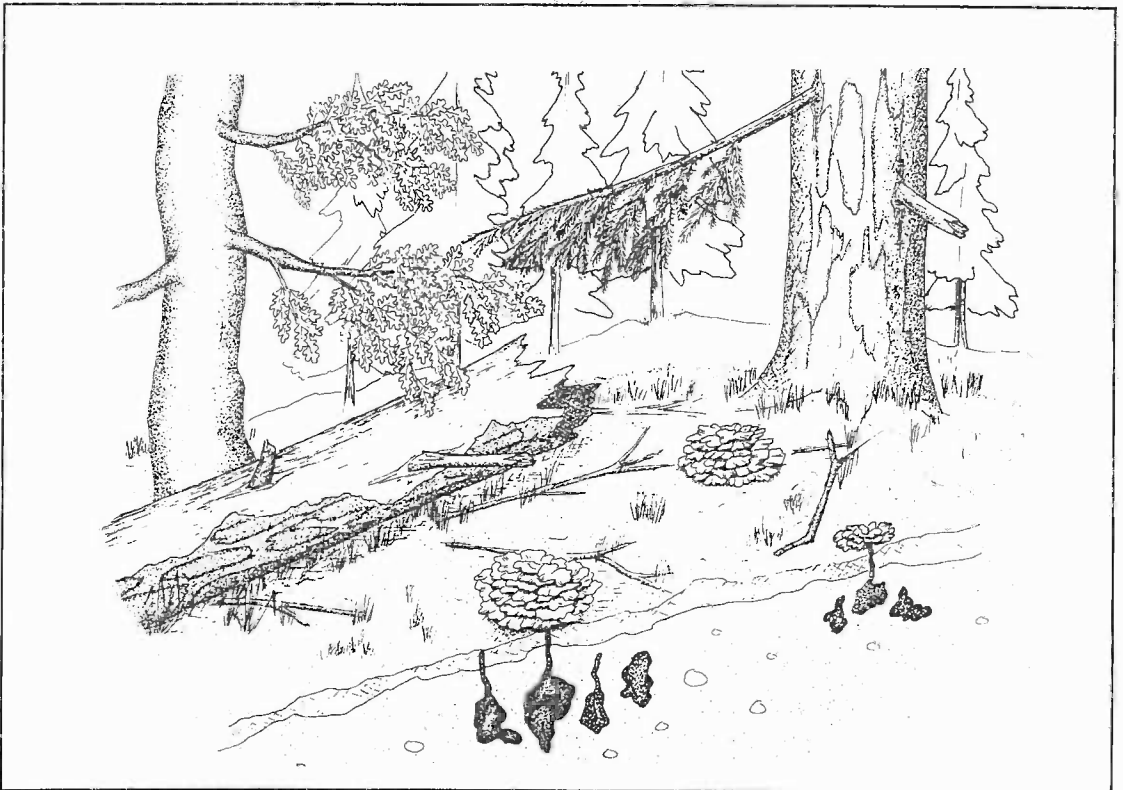

Figure 343. Zhu Ling, known to North Americans as the Umbrella Polypore (*Polyporus umbellatus*) growing from underground sclerotia.



I N D O O R   G R O W T H   P A R A M E T E R S

## The Lion's Mane of the Genus *Hericiium*

**T**he teathed fungi have many representatives, some of which are exquisitely edible. Species belonging to the Genus *Hericiium* are most notable. *Hericiium erinaceus* and *H. coralloides* produce prodigiously in culture and are the best flavored. *Hericiium abietis*, a lover of conifers, is more difficult to cultivate. This group of mushrooms, with their snow-white, distinctive appearance have long been a favorite of woodspeople. Like Shiitake, the cultivation of this mushroom probably evolved from the astute observations of those who collected them from the wild.

*Hericium erinaceus* (Bulliard: Fries) Persoon

Figure 344. *H. erinaceus* mycelia 4, 7 and 14 days after inoculation onto malt extract agar media.

**Introduction:** *Hericium erinaceus* is one of the few mushrooms imparting the flavor of lobster when cooked. Producing a mane of cascading white spines, this mushroom can be grown on sterilized sawdust/bran or via the traditional log method first established for Shiitake.

**Common Names:** Lion's Mane  
 Monkey's Head  
 Bear's Head  
 Old Man's Beard  
 Hedgehog Mushroom  
 Satyr's Beard  
 Pom Pom  
 Yamabushi-take (Japanese for "Mountain-priest mushroom")

**Taxonomic Synonyms & Considerations:** Formerly known as *Hydnum erinaceum* Fr. and sometimes improperly cited as *Hericium erinaceum* (Fr.) Pers.. *Hericium coralloides* and *Hericium abietis* are similar species, distinct in both their habitat preference and form. *H. coralloides* can also be cultivated on sawdust and differs from *H. erinaceus* in that its spines fork rather than emerging individually.

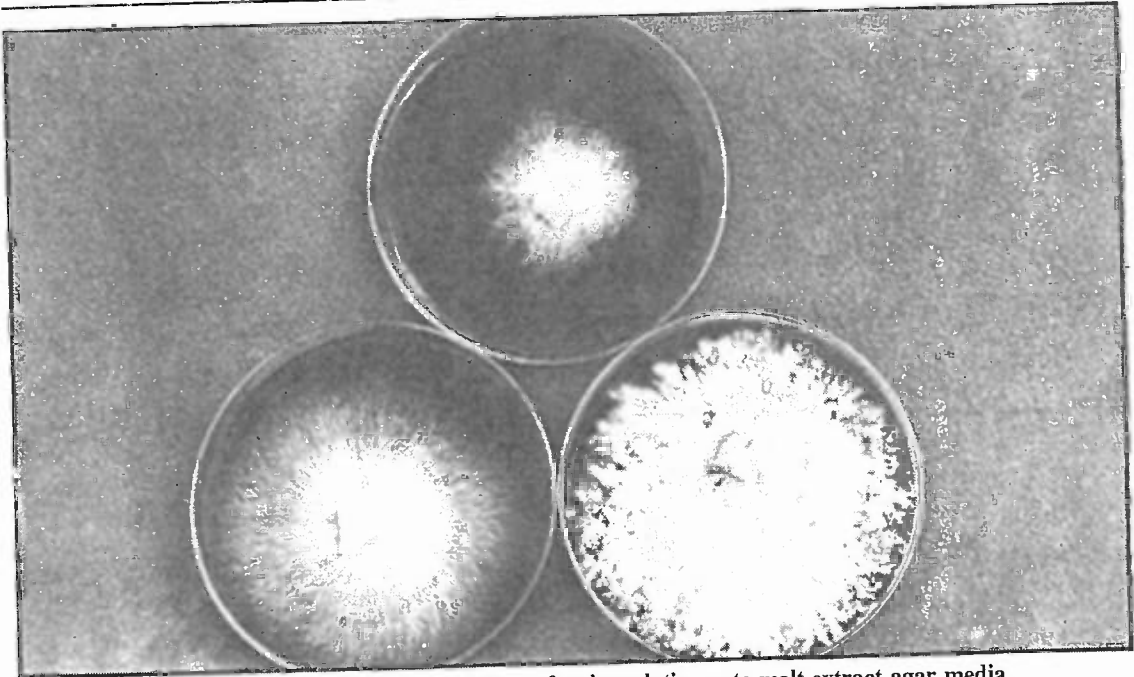
**Description:** Composed of downward, cascading, non-forking spines, up to 40 cm. in diameter in the wild. Typically white until aged and then discoloring to brown or yellow brown, especially from the top.

**Distribution:** Reported from North America, Europe, China and Japan. Of the *Hericium* species, this species is most abundant in the southern regions of United States.

**Natural Habitat:** On dying or dead oak, walnut, beech, maple, sycamore and other broad-leaf trees. Found most frequently on logs or stumps.

**Microscopic Features:** Spores white, 5.5-7.0 x 4.5-5.5 $\mu$ . Ellipsoid, smooth to slightly roughened. Clamp connections present, but infrequent.

**Available Strains:** ATCC # 62771 is an excellent, high yielding strain. Tissue cultures of wild collections vary significantly in the size of the fruitbody at maturity. I prefer to clone from the mid-section of the stem or pseudo-stem of very young specimens.

**Mycelial Characteristics:** Whitish, forming triangular zones of collected rhizomorphs, radiating from the dense center section. (The mycelium can resemble the structure of a glaciated mountain (i. e. Mt. Rainier) as seen from high overhead from an airplane.). If the top and bottom of the culture dishes are taped together, evaporation is lessened with an associated pooling of carbon dioxide. This stimulates the mycelium into aerial growth. As cultures age, the mycelia become yellow to distinctly pinkish. Islands of young fruitbodies form in petri dish cultures incubated at 75° F. (24° C.) in two to three weeks. Such fruitbodies are characterized by elongated, aerial spines ("spider-like"), which in age, change from whitish to yellowish.

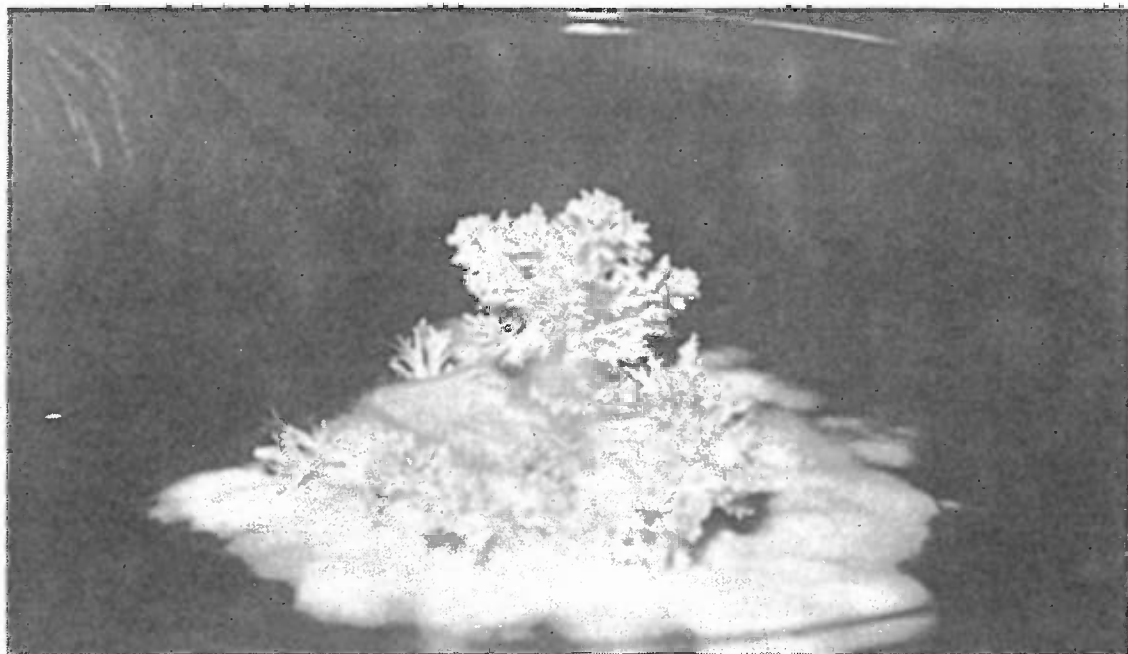

Figure 345. Miniature *H. erinaceus* fruitbody forming on malt extract agar medium.

**Fragrance Signature:** Rich, sweet and farinaceous.

**Natural Method of Outdoor Cultivation:** Inoculation of logs or stumps outdoors using sawdust or plug spawn *a la* the methods traditionally used for Shiitake. This is one of the few mushrooms which produces well on walnut logs. Oaks, beech, elm and similar hardwoods. (The "paper" barked hardwoods such as alder and birch are not recommended.) Once inoculated, the 3-4 foot long logs should be buried 1/3 of their length into the ground, in a naturally shady location. Walnut is comparatively slow to decompose due to its density, providing the outdoor cultivator with many years of fruitings. A heavy inoculation rate shortens the gestation period.

**Recommended Courses for Expansion of Mycelial Mass to Achieve Fruiting:** This mushroom, in my experience, requires greater attention to the details of mycelial development for the creation of spawn than most other species.

The mycelium grows relatively slowly on nutrified agar media, with fruitbodies often forming before the mycelium has grown to a mere 25 mm. in radius. Furthermore, the transferring of mycelium from agar to grain media using the traditional scalpel and wedge technique, results in comparatively slow growth, taking weeks to colonize unless a regimen of diligent and frequent shaking of the spawn jars is followed.

*Hericium erinaceus* is a classic example of a species which is stimulated by agitation in liquid culture. I wait until primordial colonies form upon the mycelial mat on agar media. At that time, cultures are cut into sections and placed into an Eberbach-like stirrer. Once blended, the myceliated fluid, now rich in the growth hormones associated with primordia formation, is expanded by transferring to sterilized grain filled spawn jars. The result is an explosion of cellular activity.

Two colonies of mycelium grown out on standard 100 x 15 mm. petri dishes are recommended for use with every 1000 ml. of sterile water. Once stirred, 20-50 ml. of liquid inoculum is poured into every liter to 1/2 gallon jar. The jars are then thoroughly shaken to evenly distribute the liquid inoculum, placed on the spawn incubation rack, and left undisturbed. Soon thereafter evidence of mycelial recovery can be seen, often with numerous white dense spots. These dense white spots are sites of rapidly forming primordia, now numbering many times over than that which had formed in the original petri dishes. The spawn jars must be used immediately for further expansion either into more sterilized grain or sterilized wood, lest the primordia develop into sizeable fruitbodies. Should the latter occur, further use of these spawn jars is not recommended since the developing mushrooms will be

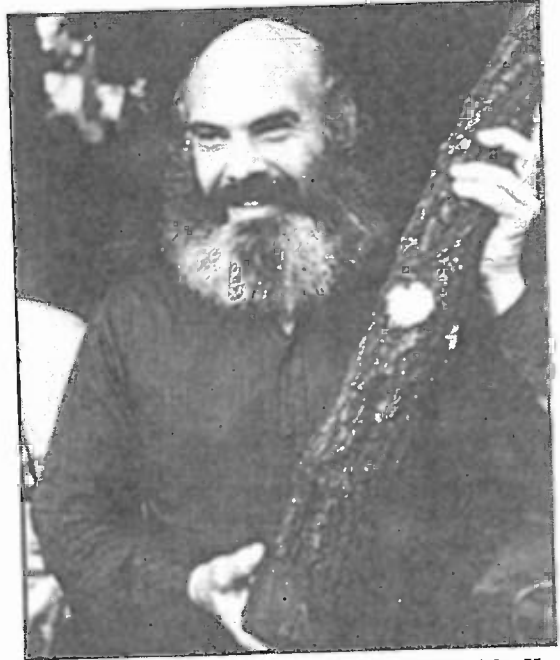

Figure 346. Dr. Andrew Weil in China with *H. erinaceus* forming on oak log.

## Growth Parameters

### Spawn Run:

Incubation Temperature: 70-75° F. (21-24° C.)

Relative Humidity: 95-100%

Duration: 10-14 days.

CO<sub>2</sub>: > 5000 - 40,000 ppm.

Fresh Air Exchanges: 0-1 per hour.

Light Requirements: n/a

### Primordia Formation:

Initiation Temperature: 50-60° F. (10-15.6° C.)

Relative Humidity: 95-100%

Duration: 3-5 days

CO<sub>2</sub>: 500-700 ppm

Fresh Air Exchanges: 5-8 per hour

Light Requirements: 500-1000 lux.

### Fruitbody Development:

Temperature: 65-75° F. (18-24° C.)

Relative Humidity: (85) 90-95%

Duration: 4-5 days

CO<sub>2</sub>: 500-1000 ppm

Fresh Air Exchanges: 5-8 hours per hour.

Light Requirements: 500-1000 lux.

### Cropping Cycle:

14 days apart.

---

damaged in the course of shaking. The subsequent transfer of these smashed fruitbodies is often followed by a massive bacterial outbreak. If the spawn remains pure, then each 1/2 gallon (liter) of grain spawn can be transferred into four 5 lb. bags of sterilized, sawdust/bran. Since this species adapts well to submerged fermentation, commercial cultivators might find the direct inoculation of sterilized grain with liquid mycelium is the most efficient path of spawn generation. (See Figure 119).

**Suggested Agar Culture Media:** MYPA, PDYA or DFA media.

**1st & 2nd Generation Spawn Media:** Grain: rye, wheat, milo, wheat, barley, corn or millet.

**3rd Generation Spawn Media:** Grain, sterilized sawdust or plugs.

**Substrates for Fruiting:** Sterilized sawdust supplemented with rice bran for indoors. Hardwood and Douglas fir logs & stumps are recommended for outdoors. The pH range for fruiting falls between 5.0 - 6.5.

---

**Yields:** 550 grams fresh weight from 5 lbs. hardwood (alder) sawdust, unenriched. 1 lb. clusters are common using the above technique. With multiple sites forming exterior to the bag, maximum yield efficiency approaches 2 lbs.

**Harvest Hints:** If inducing mushrooms to form through minute holes in plastic, the fruitbody snaps off with no need for further cleaning. Picking mushrooms in this fashion makes for some of the fastest harvesting I have seen.

**Form of Product Sold to Market:** 1/4 to 1/2 lbs. clusters carefully packaged in damage proof containers are ideal. (The size of the clusters can be controlled by limiting the number of mushrooms that form on each flush.) The relative humidity in the growing room should be lowered to 80% for 4-8 hours prior to harvest to reduce surface moisture and prolong storageability. The mushroom must be picked with great care so not to create a site for bacteria infestation which can quickly spread. Gourmet Mushrooms, a specialty mushroom company in California, sells *Hericium* and markets the mushrooms under the clever name "Pom Poms".

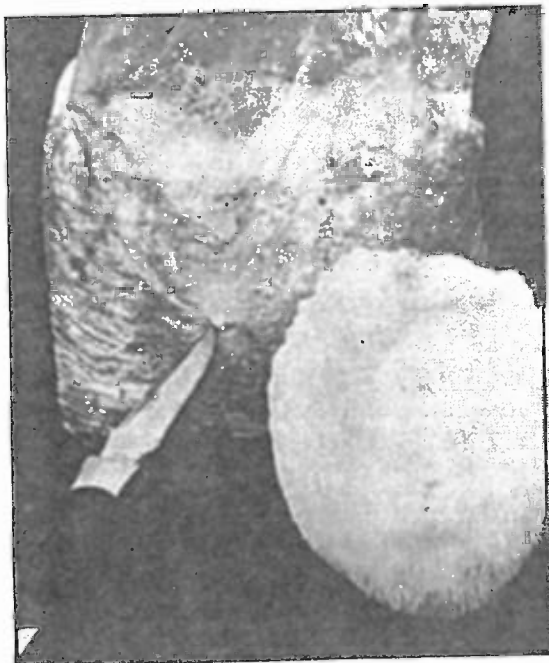

Figure 348. The 3/4 lb. Lion's Mane pictured here arose from the minute hole in the plastic seen at the tip of the knife. With this method, mushrooms can be harvested and sold with no need for cleaning.

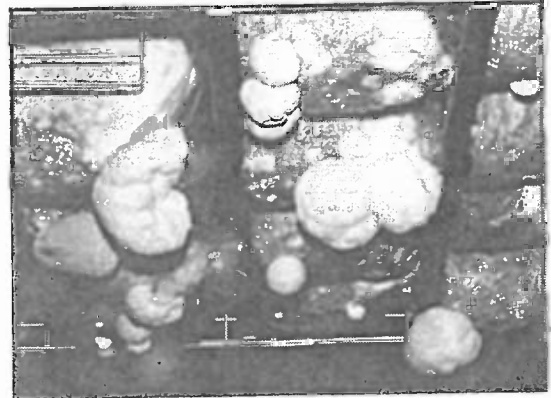

Figure 347. *H. erinaceus* fruiting from punctured bags within the growing room.

**Nutritional Content:** Not known to this author.

**Medicinal Properties:** Chen (1992) reported that studies on subjects in the Third People's Hospital of Shanghai that *H. erinaceus*, in tablet form, proved to be effective on "ulcers, inflammations, and tumors of the alimentary canal." Ingestion of this mushroom is said to have a remarkable effect in extending the life of cancer ridden patients. Ying (1987) reports that pills of this mushroom are used in the treatment of gastric and esophageal carcinoma. Fruitbodies are dried, powdered, and presented in tablet form for oral ingestion. A patent recently awarded in Japan showed that this mushroom produces Eninacines (sic) which are strong stimulators to nerve growth factor synthesis. (Kawagishi et al. 1994.)

**Flavor, Preparation & Cooking:** This is one of my family's favorite, gourmet mushrooms.



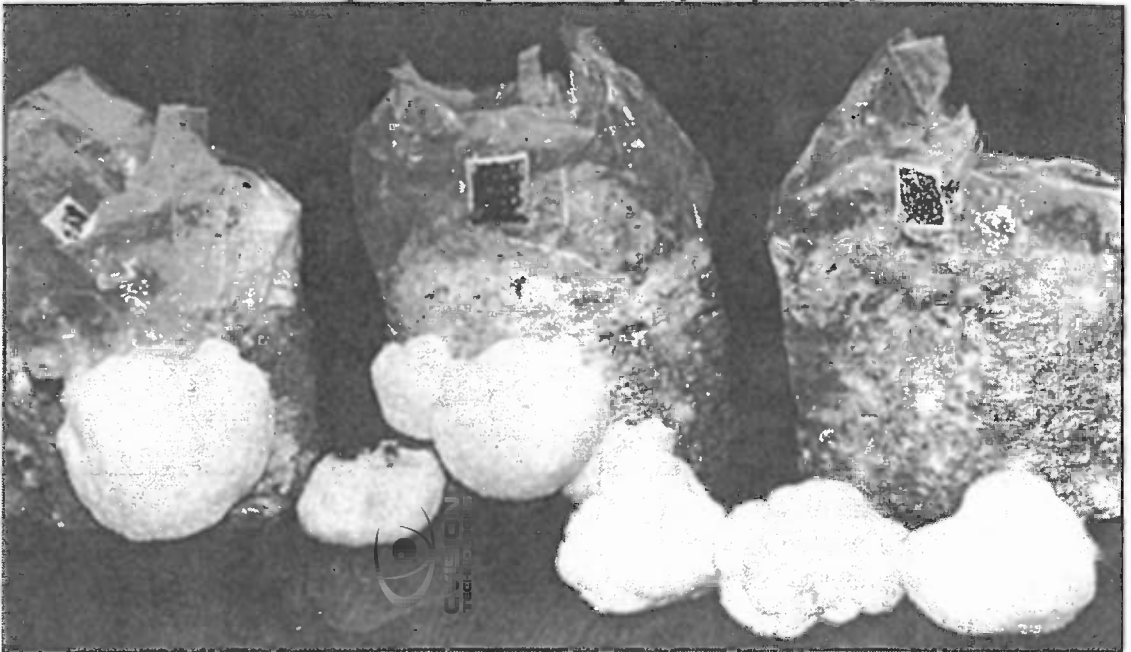

**Figure 349.** When properly initiated, mushrooms form and mature through the holes in the plastic. Once mushroom balls begin growing exterior to the bag, internal fruitings within the plenum of the bag are arrested or prevented.

Its flavor is greatly affected by the maturity of the harvested mushrooms, their moisture content, the method of cooking, and particularly the other foods that are cooked with this mushroom. To some, this mushroom has a flavor similar to lobster; to others the flavor is reminiscent of egg-plant.

We cut the mushrooms transverse to the spines, into dials and cook them at high heat in canola (rape seed) oil until the moisture has been reduced and the dials are light golden brown. (Garlic, onions, and almonds also go well with this mushroom.) The addition of a small amount of butter near the end of the cooking cycle brings out the lobster flavor. A combination of Shiitake and Lion's Mane, sauteed in this fashion, with a touch of soy or tamari, and added to white rice results in an extraordinarily culinary experience with complex, rich fungal tones.

**Comments:** This mushroom grows quickly and is acclaimed by most mycophagists. From a marketing point of view, *H. erinaceus* has distinct advantages and few disadvantages. The snow-ball like forms are appealing. Picked individually and wrapped in rice paper or presented in a see-through container, this mushroom is best sold individually, regardless of weight. A major disadvantage is its high water content and white background which makes bruising quite apparent, although the mushroom may be, as a whole, in fine shape. Once the brown bruises occur, the damaged tissue becomes a site for bacterial blotch, quickly spreading to the other mature parts of the mushroom. In short, this mushroom must be handled ever so carefully by the harvesters. By reducing humidity several hours before harvest to the 60-70% range, the mushroom loses sufficient water and tends not to bruise so readily.

*Heridium erinaceus* grows aggressively on hardwood sawdust enriched with bran. Incubation proceeds for two weeks, after which primordia occur spontaneously. Since fruitings off vertical faces of the plastic bags are more desirable than top fruitings, it is essential that holes be punched into the sides of the bags directly after colonization. Should primordia form unabated within the confines of the sealed bag, the number and quality of spines are adversely affected. Under these conditions, the spines elongate, are loosely arranged, and when they fully develop the mass of the harvested mushroom is only a fraction of what it would have otherwise been.

Few studies on the cultivation of this mushroom have been published. Most are in Japanese or Chinese. For further information, please consult Huguang (1992).

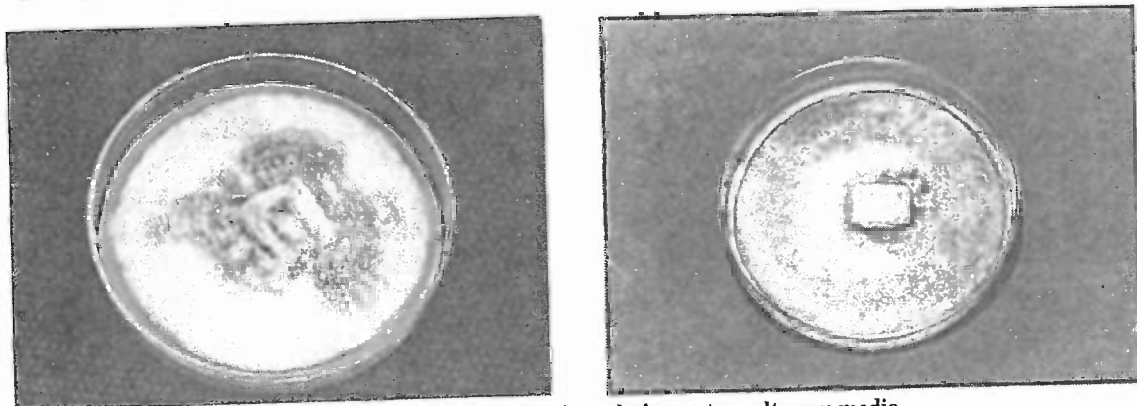

Figure 350. A one pound specimen often develops when only one primordial site is allowed per 5 pound bag of supplemented sawdust/chips/bran.

INDOOR GROWTH PARAMETERS

## The Wood Ears of the Genus *Auricularia*

**T**he Wood Ears are peculiar mushrooms which have captured the palate of Asian mycophagists for centuries. Extensive trading of Wood Ears persisted in the late 1800's from New Zealand to China and Hong Kong. Although not remarkably flavorful, these mushrooms rehydrate readily from a dried state, embellishing soups and sauces. Imparting a unique and pleasing texture to most meals, these mushrooms are a centerpiece of Asian cooking, and highly valued. In general, the cultivation methods for these mushrooms parallel that of Shiitake on logs or on sterilized sawdust.

*Auricularia polytricha* (Montagne) Saccardo

Figures 351 & 352. *A. polytricha* 6 and 12 days after inoculation onto malt agar media.

**Introduction:** According to records from China circa 600 AD., this mushroom is heralded as the first species to be cultivated, (Chang & Miles, 1987 & 1989). This mushroom has an unusual, appealing texture when eaten but, by itself, is not remarkably flavorful. Nevertheless, *A. polytricha* is highly prized in Asia and is commonly used in soups. Upon drying, Wood Ears shrivel to a fraction of their original size, and upon contact with water, rehydrate and enlarge true to form.

**Common Names:** Wood Ear or Ear Fungus  
 Tree Ear or Maomuer (Chinese)  
 Yung Ngo or Muk Ngo (Chinese)  
 Mu-er, Mo-er (Chinese, often also used for *A. auricula*)  
 Kikurage (Japanese for "Tree Jelly Fish")  
 Mokurage (Japanese)  
 Aragekikurage (Japanese)

**Taxonomic Synonyms & Considerations:** At least three very similar Wood Ear taxa occur in the Americas. *Auricularia polytricha* (Montagne) Saccardo has been reported in Louisiana, but is also common from the Americas through Mexico and south to Argentina. It is brownish and coarsely hairy on its outer surface with the hairs measuring up to  $450 \times 6 \mu$ . The common northern temperate species of Wood Ear bearing strong resemblance to *A. polytricha* is *Auricularia auricula* (Hooker) Underwood which is brownish and finely hairy on its outer surface. The hairs of this latter species is much shorter, measuring  $100 \times 6 \mu$ . (See Lowy (1971)). As a cultivator, I find that humidity has a great affect on this character. Hence, the delineation of these two taxa is often difficult, underscoring their close alliance. One other feature proposed for delineation is the presence or absence of clamp connections. *A. polytricha* has them; *A. auricula* does not. In the Orient, *Auricularia auricula* is generally collected from the wild and not as widely cultivated. The Japanese call *A. auricula*—"Senji" whereas

*A. polytricha* is mostly referred by the name “Kikurage”. Most cultivators not trained in the skills of taxonomy are likely to pass on the mistaken identifications of those before them. With the many “varieties” of Wood Ears circulating, the need for interfertility studies and DNA comparisons is evident.

According to Wong & Wells (1987), the proper name for the cultivated *A. polytricha* should be *Auricularia cornea* (Ehr. :Fr.) Ehr. ex Endl. Until I can further study these taxa and their arguments, I am retaining the name *A. polytricha* for this mushroom. Another closely related species is *Auricularia fuscossuccinea* (Montagne) Farlow, the most common Wood Ear in the southeastern United States. This mushroom is rosy to reddish brown and minutely hairy on its outer surface (with hairs measuring  $80 \times 5 \mu$ ). This species is distributed as far south as Argentina.

**Description:** A gelatinous cup fungus, ear-shaped, generally purplish grayish brown to dingy brown, 2-15 cm. broad, sessile. Covered by a medulla of fine hairs. Surface smooth, wrinkled towards the center and upturned towards the outer edges. Firmly gelatinous in texture. Readily rehydrating true to form.

**Distribution:** Varieties of Wood Ears grow throughout the temperate hardwood forests of the world.

**Natural Habitat:** On conifer or hardwood logs or stumps, especially oaks, willows, locust, mulberry, acacia and other broad-leaf trees. Commonly occurring in soils rich in wood debris during the cool wet seasons throughout the temperate forests of the world. This mushroom generally favors cool weather and grows from sea-level to tree-line.

**Microscopic Features:** Spores white in deposit, otherwise hyaline, cylindrical to sausage shaped, 11-14 (17.5)  $\times$  4-6  $\mu$ . Clamp connections present.

**Available Strains:** Strains are available from most culture libraries. Wild specimens abound and can be easily brought into culture. Strains of *A. auricula* and *A. polytricha* are often mis-labelled due to the difficulty in separating these taxa from one another.

**Mycelial Characteristics:** Longitudinally linear, thickening with age to form a dense cottony white mycelial mat, becoming mottled with brown discolorations in age.

**Fragrance Signature:** Unpleasant, musty, reminiscent of a raw compost.

**Natural Method of Cultivation:** The most common technique used in Asia has been to cut logs 3 feet or a meter in length, 5-12 inches in diameter, in the late fall to early spring. The logs are simply drilled with holes and spawn is packed tightly into the cavities. I prefer to inoculate logs with sawdust spawn that is packed into chain-saw cuts a foot apart. The logs are kept moist in a shaded, well ventilated forest. To initiate mushroom formation, the logs are submerged in water for 24 hours.

**Recommended Courses for Expansion of Mycelial Mass to Achieve Fruiting:** From liquid inoculated Grain Masters, a 2nd generation of grain spawn in gallon jars can be inoculated. Each gallon jar of spawn can inoculate 10 5 lb. bags of sawdust supplemented with rice bran. Chopped corn and rye flakes can also be used as supplements.

**Suggested Agar Culture Media:** MYA, MYPA, PDA, PDYA or DFA.

**1st, 2nd & 3rd Generation Spawn Media:** Millet, milo, rye, wheat or sorghum all support the for-



Figure 353. *A. polytricha* in classic form.

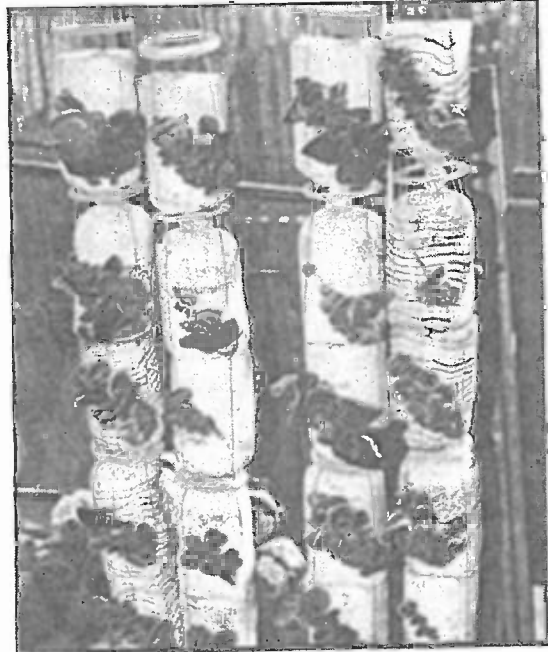

Figure 354. Cylinders of sterilized sawdust are suspended in the growing room and punctured to elicit fruitings off the vertical faces.

mation of a vigorous and luxuriant mycelial mat.

**Substrates for Fruiting:** Essentially the same hardwoods that are recommended for Shiitake support good fruitings of this species. In Asia, *Acacia* spp. are widely used. The ideal pH range is between 6.5-7.0. Wheat straw has been used successfully (Jianjun, 1991), especially when sawdust spawn is used.

**Recommended Containers for Fruiting:** Polypropylene bags and bottles. Each should be punctured with 10-20 holes after full colonization (25-40 days after inoculation) to localize primordia formation.

**Recommended Cropping Containers:** Polypropylene bags and bottles. One method uses cylindrically shaped polypropylene bags, 6-8 inches in diameter, that are cut open at both ends and laid horizontally to build a wall of exposed surfaces. From these open ends, the Wood Ear mushrooms emerge. Others use polypropylene spawn bags fitted with a microporous filter patch. These bags are usually punctured to encourage mushroom formation around the bags, or are partially opened at the top to elicit a surface flush of mushrooms. I personally prefer the puncture hole technique.

**Yield Potential:** 1/4 to 1/2 lb. of mushrooms per 5 lbs. of supplemented sawdust. Logs produce for several years, yielding at best, 20% of their wet mass into fresh mushrooms over 3-5 years.

---

## Growth Parameters

### Spawn Run:

Incubation Temperature: 75-85° F. (24-30° C.)

Relative Humidity: 90-95%

Duration: 25-40 days.

CO<sub>2</sub>: > 5000 - 20000 ppm

Fresh Air Exchanges: 0-1 per hour.

Light Requirements: not needed

### Primordia Formation:

Initiation Temperature: 55 - 70° F. (12-20° C.)

Relative Humidity: 90-100%

Duration: 5-10 days.

CO<sub>2</sub>: 600-1000 ppm

Fresh Air Exchanges: 5-8 per hour.

Light Requirements: 500-1000 lux.

### Fruitbody Development:

Temperature: 70-85° F. (21-30° C.)

Relative Humidity: 85-90%

Duration: 5-7 days.

CO<sub>2</sub>: 2000-5000 ppm

Fresh Air Exchanges: 4-5 per hour.

Light Requirements: 500-1000 lux.

### Cropping Cycle:

Every two to three weeks for 3-5 flushes.

---

**Harvest Hints:** If mushrooms form through holes in the plastic, harvesting is fast and efficient. Clusters of these ear shaped mushrooms pop off without residual substrate debris.

**Form of Product Sold to Market:** Fresh and dried. The greatest volume of this mushroom is sold in dry form. Although dark when dried, these mushrooms lighten to brownish in color as they rehydrate, usually true to form. The rubbery and cartilaginous consistency is strangely appealing.

**Nutritional Content:** 8-10% protein, 0.8-1.2% fat, 84-87% carbohydrates, 9-14% fiber, and 4-7% ash. (Ying, 1987; Chang & Hayes, 1978). Moisture content of fresh mushrooms is usually within a few percentage points of 90%.

**Medicinal Properties:** Ying (1987) reports that this mushroom is 80 & 90% effective against Ehrlich carcinoma and sarcoma 180 respectively. The supporting references are in Chinese.

A hematologist at a medical school in Minnesota pricked his finger in a blood clotting test, and when his blood failed to clot, the ensuing investigation traced the cause to the Wood Ear mushrooms he had eaten the night before at a Chinese restaurant. In the United States during the 1970's, when

---

Chinese restaurants started using an abundance of Wood Ear mushroom, some patrons noted spontaneous blotchy hemorrhages of the skin in the days following a meal rich with these mushrooms. This was dubbed the Szechwan Restaurant Syndrome and later became known as Szechwan purpura. (Hammerschmidt, 1980; Benjamin 1995). This discovery has led to a new anticoagulant effective in the prevention of blood clots.

**Flavor, Preparation & Cooking:** For me and many others, this mushroom is not remarkably flavorful. However, this mushroom adds another dimension to the culinary experience. *A. polytricha* has a most appealing brittle-gelatinous texture, potentiating the flavors of foods cooked with it. I have seen chefs embellish salads with this mushroom, uncooked, as a garnishment.

**Comments:** This mushroom is extremely popular in Asia and to a much less extent, in Europe. In the United States, this mushroom is used primarily by those of Asian descent. Appealing for its ease of use, Wood Ear mushrooms dry and rehydrate quickly.

The method of cultivation closely parallels that of Shiitake. The punctured polypropylene bags should be placed in a 100% or condensing fog environment to encourage the emergence of mycelium. Once mushroom initials form, the atmosphere should clear of condensing fog but be held at 95-100% humidity. Watering two to four times a day brings on fruitbody formation within 5-10 days. If by third flush, substrate moisture has fallen below 50% and can not be replenished through frequent watering, submerging the sawdust bags will induce one last substantial flush.

Imazeki et al. , (1988) rates *A. auricula* as superior to *A. polytricha* in culinary terms. *A. auricula* can be grown in the same fashion as *A. polytricha* except that *A. auricula* thrives in the 50°-60°F. (10-15 C.) range. These differences may be varietal in nature—assuming that the taxa of *A. auricula* and *A. polytricha* are conspecific.

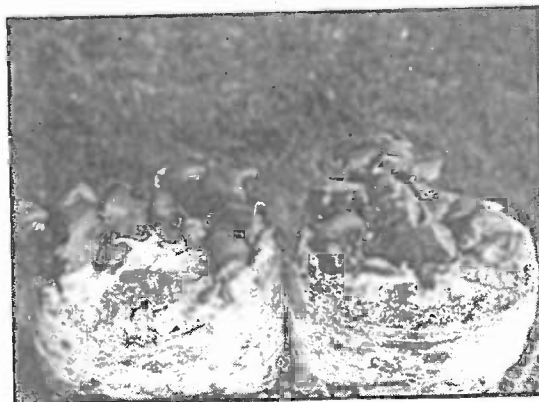

Figure 355. *A. polytricha* can be grown from a horizontal surface. However, most cultivators prefer to crop the mushrooms from vertical faces as featured in Figure 354.



## The Morels: Land-Fish Mushrooms\* of the Genus *Morchella*

**M**orels embody the mystique of mushrooms. They are elusive, highly camouflaged, and appear for just a few days in any one place. Finding Morels in the wild tests the skills of even the most experienced mushroom hunter. Once found, Morel patches are guarded by secrecy and treasured like family heirlooms. Revealing the location of a Morel patch is an admirable expression of friendship and trust . . . and, it may be the most foolish thing any Morel hunter can do!

In northern latitudes, from April to June, Morels grow in several specialized habitats. They thrive in abandoned apple orchards; at the bases of dying and dead elms; around living cottonwoods, oaks and poplars; in sandy gravel soils along rivers and streams; in “beauty bark” used for landscaping; at the bases of young firs; in the tracks left by bulldozers punching new roads through forests; in limed soils, and in the wastelands left by fires.

\* “Land Fish” is a Native American name, possibly Mohawk, aptly given to Morels.



Figure 356. The aftermath of the Yellowstone Fire created an ideal habitat which yielded huge quantities of edible & choice Morels.

What in the world could be the common denominator shared by all these habitats? Who knows? The only habitats I can easily recreate are the aftermath of the fire, the beauty bark bed and the gravel road bed. Of these, the fire-treated habitat has proved the most reliable, and reproducible. Fire destroys competitors and reduces nutrient levels of carbon and nitrogen while proportionately increasing levels of calcium, potassium and mineral salts. This wasteland supports little life, save for the treasured Morel.

When nature suffers a catastrophe, the Morel life cycle lies ready in the waiting. How Morels thrive in the charred desolation left by a forest fire is, in itself, mystifying. In the spring of 1989, after the massive Yellowstone fires of the previous summer, huge fruitings of Morels emerged from the ashen landscape. Some of the largest Morel finds in history were discovered one year after the Mt. St. Helen's eruption. So abundant were the fruitings that excited collectors filled their pick-up trucks to the brim with hundreds of pounds of Morels. To their dismay and disbelief, the gritty ash made the mushrooms entirely inedible.

Stories of unusual morel fruitings are as enticing as they are bewildering, and in certain cases approach legendary status. Here are a few examples:

- A massive Morel fruiting occurred several weeks after sludge from a Washington pulp company was flooded into a tree nursery. Thousands of Morels sprang up.
- After a flood in eastern Oregon, where a family's backyard was under a foot of water for more than a week, Morels weighing several pounds soon followed. (See Figure 357.)



Figure 357. This 4 lb. Morel was discovered in a backyard after flood waters receded.



Figure 358. The freak occurrence of Morels popping up from nursery grown, potted Phlox plants still mystifies me. This discovery steered me onto a fruitless path of experimentation.

- A rain soaked and decomposing straw bale in the middle of a wheat field yielded an enormous Morel weighing several pounds.
- From the ruins of a house destroyed by fire in Idaho, huge Morels were found in a basement coal bin. The strain I cloned from these mushrooms is known as "M-11" and is featured in this book.
- A local nursery was selling Phlox plants and from every pot Morels were sprouting. (See Figure 358.)
- An old timer recently told me that, after shooting a chicken-killing dog one autumn, he was shocked to find Morels fruiting in a circle around the decomposing carcass the following spring. (I forgot to ask him whether or not he ate the Morels....)
- Recently, an excited women called me from Napa Valley, California. To her family's utter disbelief they found a Morel fruiting from the ashes of their indoor fireplace. The fireplace had not been used for 6 months. They have no idea how it got there.
- Near Vancouver, Washington one of my students planted Morel spawn into the ashes of his barbecue grill which was located on a verandah of his condominium. He was amazed to find Morels popping up from his hibachi several months later.

Baffling and beguiling, Morels continue to tease us with their peculiar sense of humor. If any readers know of similarly unusual encounters of the Morel kind, I would like to know. Please write me c/o Fungi Perfecti, P.O. Box 7634, Olympia, Wa. 98507 USA.

## The Morel Life Cycle

Morel spores germinate quickly. The hyphae race through the environment—up to four inches per day. Morel mycelium can colonize a vast territory in a relatively short time. But when they encounter a physical boundary, a non-nutritional zone, or competitors, the mycelium stops expanding. After experiencing environmental shock, the mycelium collapses and forms a subterranean structure called a *sclerotium*. Understanding sclerotia is the key to Morel cultivation.

A sclerotium is a hardened, asexual mass of cells which roughly resembles a gold nugget or walnut in form and size. Sclerotia are produced by many mushroom species, including *Collybia tuberosa*, *Conocybe cyanopus*, *Hypholoma tuberosum*, *Polyporus umbellatus*, *Pleurotus tuber-regium*, *Poria cocos*, *Psilocybe mexicana*, *Psilocybe tampanensis*, and dozens of others. (See Figures 42, 43, & 341). The mushrooms which form sclerotia tend to be soil-dwellers. The sclerotia represent a nutrient storage and resting stage, allowing the mushroom species to survive inclement weather. They can be dried to the point of flammability, and upon rehydration, as the cells swell with moisture, the sclerotium springs to life and transforms into either a mushroom or into a new mycelial network. Morel mycelium produces sclerotia naturally, without the interference of humans, on many habitats from peat moss to sand to straw.

The sclerotia of the Black Morel are uniquely different than all the other Morel species. The sclerotia of the Yellow Morel, *Morchella esculenta* and the so-called Giant Morel, *Morchella crassipes* are dense, slippery and heavy when fresh, dark and & walnut-like. The sclerotia of the Black Morel, *Morchella angusticeps* are abrasive, golden yellow to orange, light in weight when fresh, and pumice-like. Although studies on the sclerotia formation of *Morchella esculenta* and *Morchella crassipes* have been published (Ower (1982), Ower & et al. (1986, 1988), and Volk & Leonard (1989, 1990)), no studies have been published on *Morchella angusticeps* until now. One other difference: the sclerotia of the Black Morels form by the

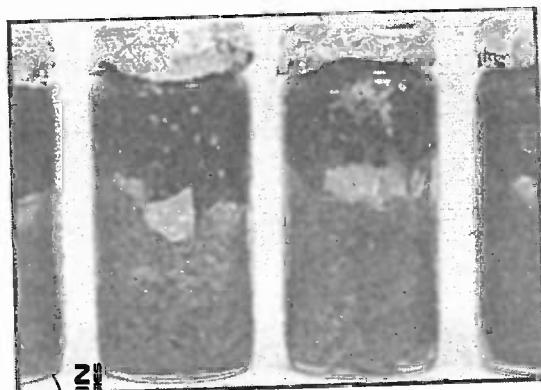

Fig. 359. Sclerotia of the Giant Morel, *Morchella crassipes*, forming in jars. Soil is placed onto colonized grain. The mycelium grows into the soil and, after several weeks, forms sclerotia. As with most sclerotia-forming mushroom species, this phenomenon is encouraged by darkness during incubation.

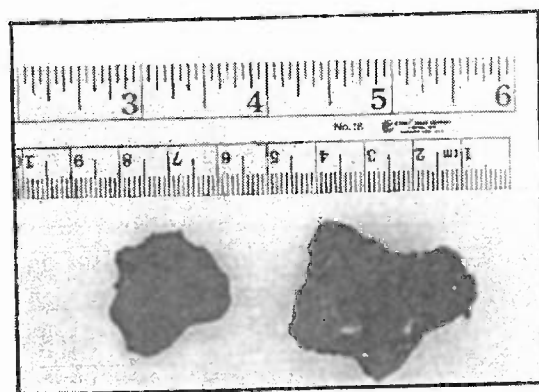

Figure 360. The harvested Morel sclerotia can grow to several inches in diameter.

thousands per cubic foot whereas the sclerotia of the Yellow Morels are comparatively few in number. The differences between these two groups of Morels are soon seen after the clones or spores are put into culture.

Although Ron Ower (1986) was the first to note that Morels arise from sclerotia, the first to propose a complete Morel life cycle was Thomas Volk (1990), a rendition of which follows. Not fully illustrated in this life cycle is the asexual phase wherein sterile cells are borne on short hyphal branches, similar to oidia. An abundance of these asexual spores forms a powdery mildew, and has been called *Costantinella cristata* Matr. (Costantin (1936)).

### The Development of Indoor Morel Cultivation

All attempts at controlled, indoor Morel cultivation failed, until Ron Ower succeeded in 1982. By his own admission, the discovery of Morel cultivation was more by accident than design. And, Ron Ower told me that his experiences growing *Psilocybe* mushrooms combined with an "accident in the laboratory" led to success. (He revealed he had used the casing formula outlined in my first book, *Psilocybe Mushrooms & their Allies* (Stamets (1978)) as the sclerotia-forming formula.) Under pressure from venture capitalists, Ron Ower applied for and was awarded two patents, along with G. Mills

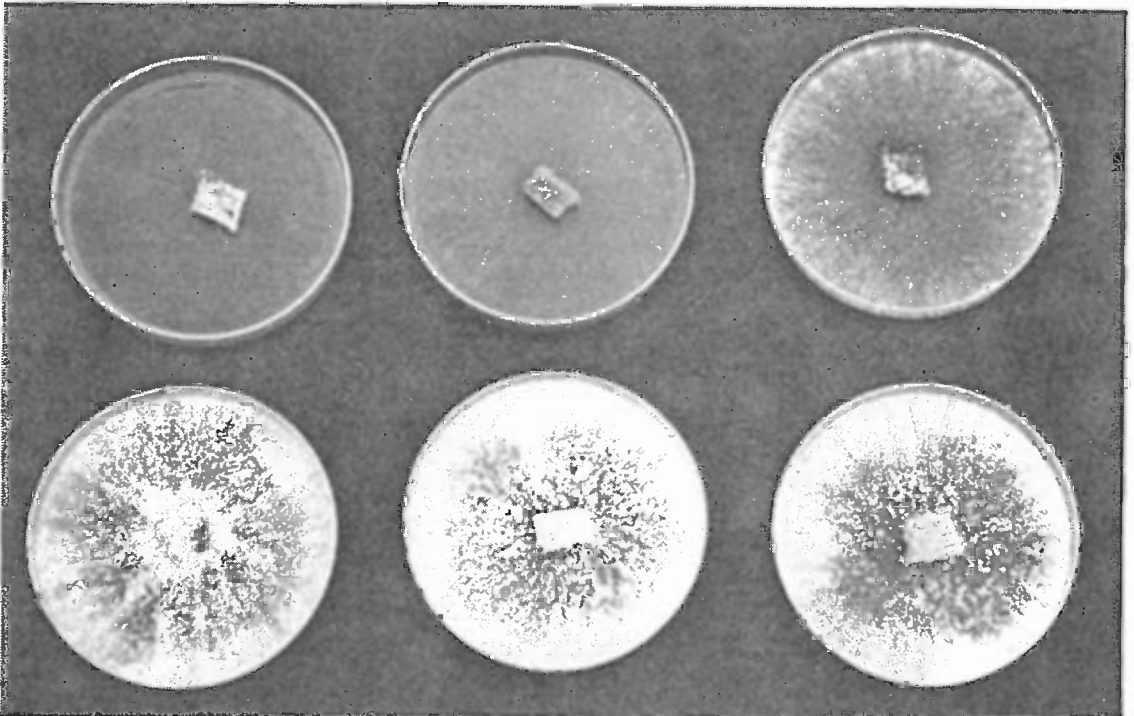

Figure 361. Six day sequence of the growth of *Morchella angusticeps* (Stamets strain # M-11). Note rapid rate of growth and the formation of "micro-sclerotia". This strain loses the ability to form micro-sclerotia when propagated more than 5 petri dishes from the original culture. Downstream inoculations into all bulk substrates are similarly affected.

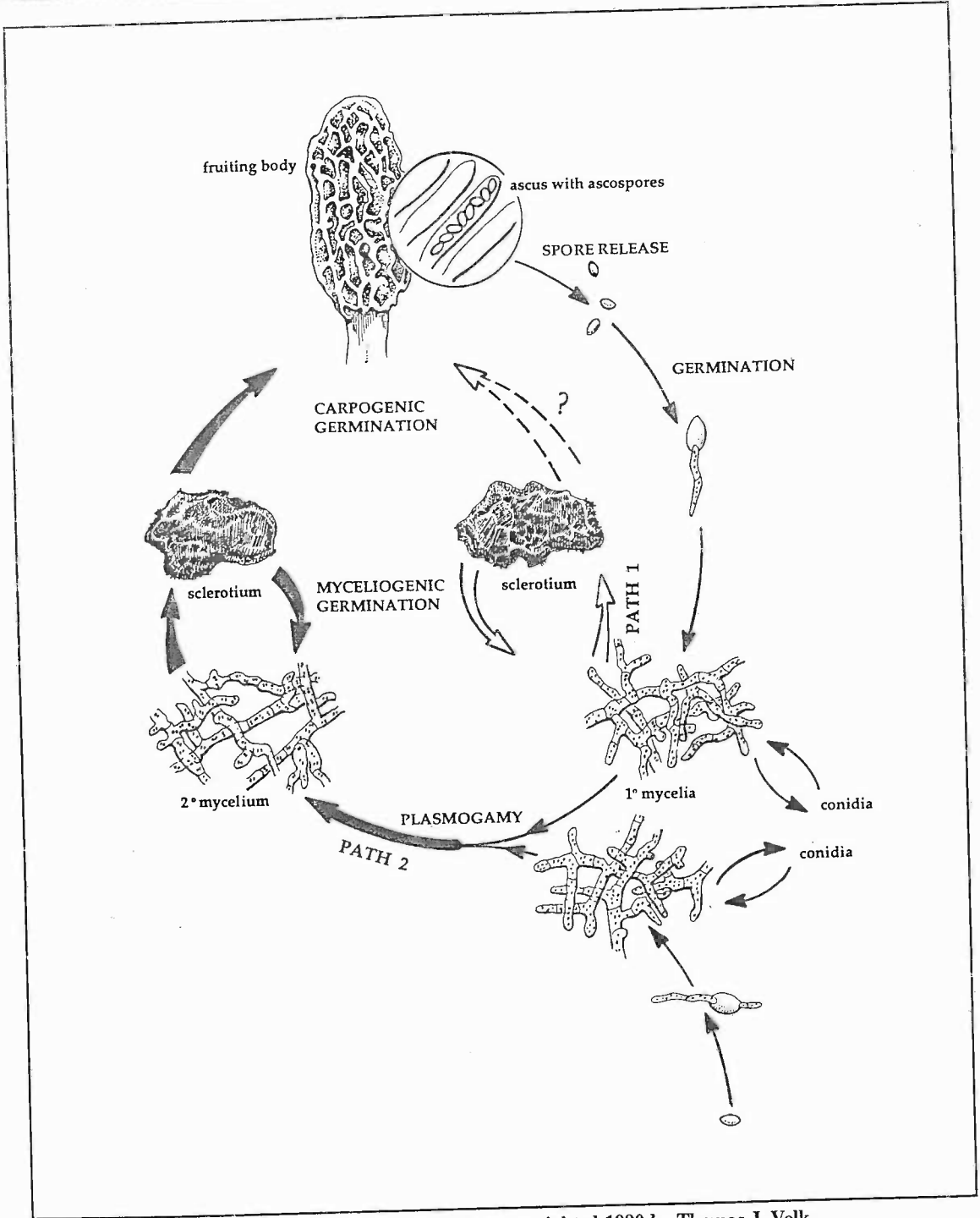

Figure 362. Life Cycle of the Morel by Kandis Elliot, copyrighted 1990 by Thomas J. Volk.

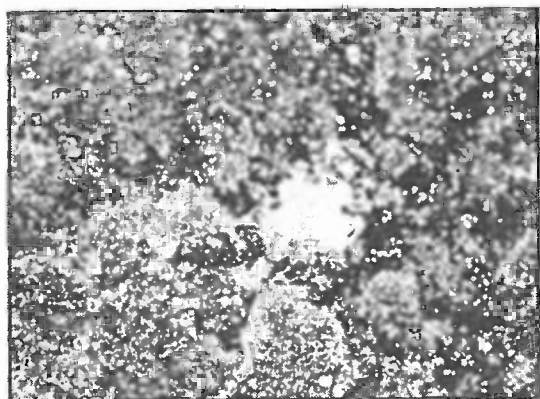
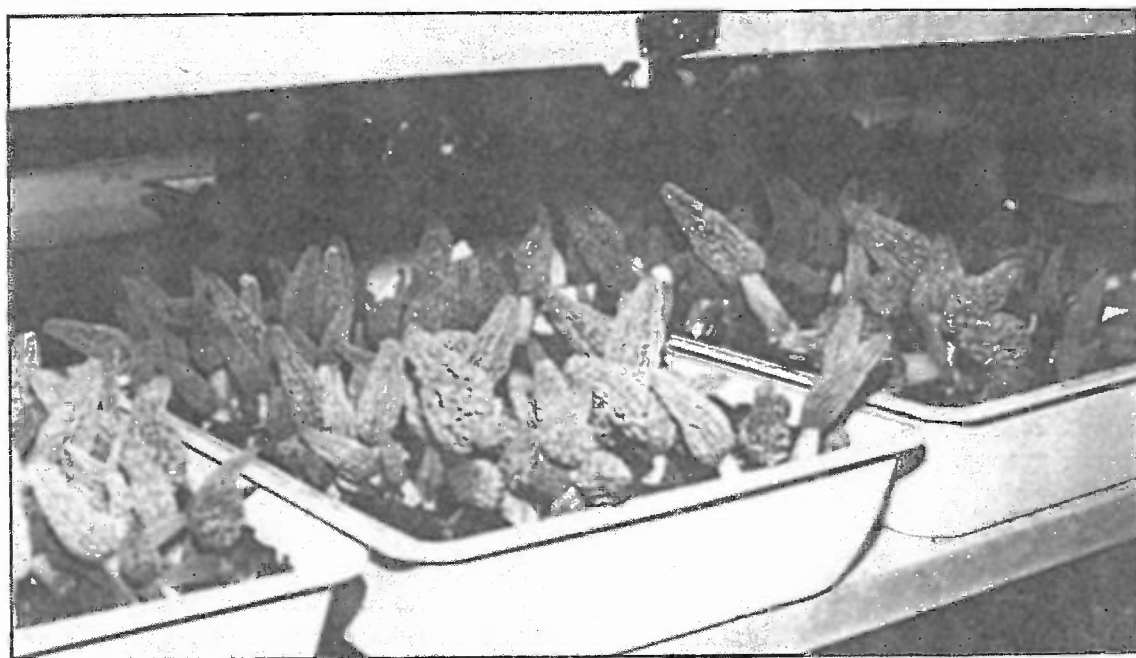

Figure 363. A Morel primordium forms.



Figure 364 & 365. *Morchella esculenta* fruiting in trays at Morel Mountain. The technique they have developed is patented, and is still mystifying to all but them.



and J. Malachowski, for the cultivation of *Morchella esculenta*, the Yellow or White Morel. (Ower et al., 1986 & 1988). The patent describes a technique whereby the Morel mycelium is grown from a nutritious food source into a non-nutritious medium. Once physically separated, the mycelium forms sclerotia in the nutritionally impoverished substrate. After a period of dormancy the sclerotia are saturated with water, swell, and when subjected to *specific environmental conditions* metamorphose into Morel mushrooms.

One test of a patent is that it is reproducible. In the 7 years since publication, I know of no mycolo-

gist who has grown morels using the techniques outlined by the patent. Either the strain that is being grown is unique, or critical information, obviously proprietary, has been left out. To this day, I do not know what is missing. However, the growers at Morel Mountain, the company using the patented method, should be complimented for their skill at mushroom cultivation. They are accomplishing a feat in mushroom cultivation that has foiled the attempts of skilled mycologists worldwide.

I have some insights which may be useful in the cultivation of a related species, the famous Black Morel, *Morchella angusticeps*. My research has concentrated on the cultivation of the Black Morel because this species is the most common Morel in western Washington State, where I live. All readers of this book are encouraged to experiment with Morel cultivation, and develop their own, unique techniques which do not come into legal conflict with the patented processes. To date, all cultivated mushrooms can be grown by more than one method. For instance, Oyster mushrooms can be grown on straw or sawdust or coffee plants. Over the years many techniques have evolved for culturing Shiitake, Nameko, Reishi and Shaggy Manes. With more experimentation, Morels will be no exception.

---

---



*Morchella angusticeps* Peck complex

Figure 366. *Morchella angusticeps* mycelia 3, 5 and 7 days after inoculation onto malt agar media.

**Common Names:** The Black Morel  
The Conic Morel  
Peck's Morel

**Taxonomic Synonyms & Considerations:** Morel taxonomy, to put it politely, is horribly confused. From the same culture, I have grown Morels totally dissimilar in appearance, bolstering my suspicions about the divisions between "species". My experiences reveal that the growth environment has a radical effect on morphology. And, from a cultivator's point of view, I see some natural groupings.

The Morel taxa, which include all the white, yellow and black forms, are far too numerous to list here. However, the Black Morels are a naturally definable cluster, including *Morchella angusticeps*, *M. conica*, and *M. elata*. In culture, they behave similarly. I would not be surprised if they are all found to be the same species in the broadest sense. A new, totally Black Morel, covered with a fine fuzzy coat, is called *Morchella atrotomentosa* (Moser) Bride, a mushroom that was uncommon in North America until the year after the Yellowstone fires. (See Figure 368). This Morel is so unique in its appearance that I would be surprised if it shared synonymy with any other. The Yellow or White Morels include *Morchella esculenta*, *M. deliciosa* and *M. crassipes*. These morels are extremely similar and probably cross-over taxonomically. The Half-free Morel, *Morchella semilibera*, which has short cap overhanging the stem, also stands apart from these other Morels. New DNA studies are soon to be published which should shed light onto the abyss of Morel taxonomy.

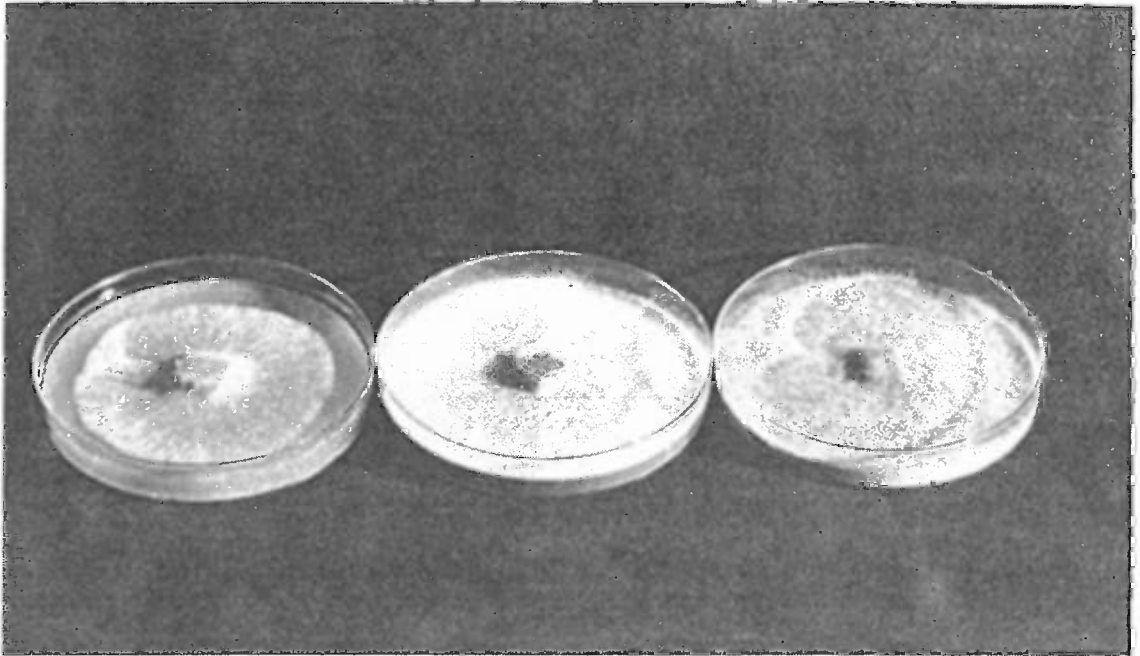
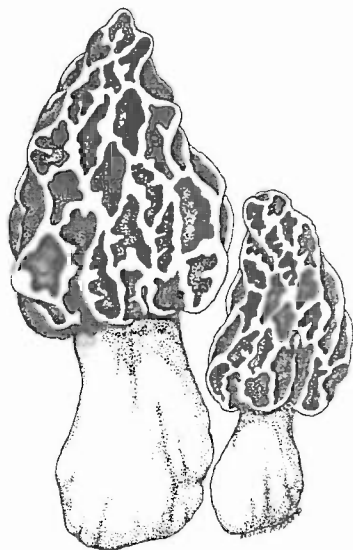

Figure 367. Portrayal of the archetypal Black Morel, *Morchella angusticeps* complex.

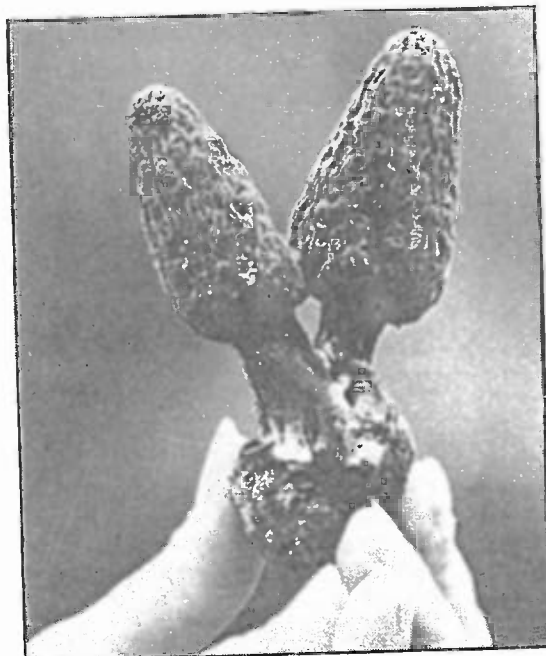

Figure 368. The unique *Morchella atrotomentosa*. These two specimens were collected from a burnsite in Kamilche Pt., Washington, in the spring of 1988. Note the coat of fine hairs.

**Description:** A honey-combed, ribbed species with black edges, the cap is typically conical shaped, measuring 2-6 cm. wide x 2-8 cm. high. Stem white, hollow, with a granular texture, measuring 5-12 cm. long by 2-4 cm. thick. White mycelium is attached to the base of the stem.

**Distribution:** Widely distributed throughout the temperate regions of the world.

**Natural Habitat:** Common in the spring in a variety of habitats, particularly in sandy soils of mixed woods along rivers, in burned areas (1-2 years after burning), and less frequently in conifer forests. On the west coast of North America, this mushroom is commonly found in newly laid wood chips ("beauty bark"). In the Pacific Northwest, Black Morels are also found directly underneath cottonwoods and neglected apple trees. David Arora notes that along coastal California, Morels can be found throughout the year, although they are more frequent in the spring. (Arora, 1986.) In general, fall fruitings are rare and unpredictable. In Colorado's Front Range, just outside of Denver, Morels are a spring mushroom, but in the mountains around Telluride, Black Morels can be occasionally found in August, under spruce.

**Microscopic Features:** Spores light creamy brown, 24-28 x 12-14  $\mu$ , ellipsoid and smooth, forming 8 at a time in sac-like cells called asci. Mycelia typically multinucleate, with frequent side branching at maturity, clustering and swelling into micro-sclerotia which conglomerate into larger forms.



Figure 372 & 373. From the spawn featured in Figure 370, several forms of Morels showed. The large specimen with the pitted stem and conic cap weighed 1/4 lb. The round headed one weighed approximately half as much. A taxonomist would be hard pressed to call these the same species, but a cultivator sees such differences in form frequently from the same culture.

If you do not have a burnsite, but have a woodstove or like to barbecue in the summer, then those ashes can be mixed with other ingredients to create a Morel patch. Mix equal portions of the following ingredients.

10 gallons of peat moss

5 gallons of ash

1 gallon of gypsum (calcium sulfate)

Mix the ingredients in dry form. Find a shady, well drained location and remove all topsoil until "mineral-earth" is exposed. Lay down the mixture to a depth of 4 inches to cover as broad an area as this volume makes. Water until saturated. Using a shovel or spade, mix in



Figure 374. Another burn-site inoculated with "M-11" Morel spawn produced these succulent, fruitbodies.



Figure 370. Two bags of sawdust spawn (Stamets strain M-11) were inoculated into a burnsite December 27th. (Figure 371.) Morels appeared May 4th.

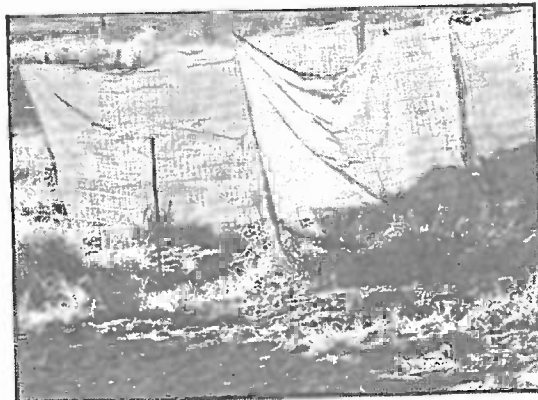

Figure 371. The patch was located in a field (poor location) where no Morels would grow naturally. A shade cloth protected the patch from sun and deer.

*becomes the cultivator.* In tracking temperatures, I believe the temperature fluctuation from day to night, a circadian cycle, is critical for the formation and development of Morels. From my charts, I have found that limited temperature changes, from 40-60° F. (4-16° C.) for several weeks during early spring triggers mushroom formation. Once the seasonal temperatures move beyond this critical period of fluctuation, no new Morels form. Temperatures as high as 60° F. (15. 6° C.) cause the young mushrooms that have formed to rapidly develop to maturity.

Morels are easy to grow by buying spawn and implanting it into your backyard. Fall plantings have the highest success rates which I estimate at 50%. However, it takes only a few minutes to install a Morel bed, especially if you have ready access to wood ash or a burnsite. Once a fruiting Morel patch is established, the success rate jumps to about 90% for subsequent years, provided a new habitat is created and additional spawn is introduced at the same time each year. In Nature, every ecological niche is unique. The trick is to not only find the right location for your Morel patch, but to have conducive weather conditions in the early spring. Protecting the Morel patch from the sun and marauding animals is absolutely essential.

First, acquire sawdust spawn of a proven, fruiting strain of *Morchella angusticeps*. Five pounds of Morel spawn is roughly equivalent to a gallon. This amount of spawn is good for inoculating a 4 ft. x 4 ft. to 10 ft. x 10 ft. bed. Inoculations are best conducted in the summer to early fall. Black Morel spawn is available from **Fungi Perfecti** whose address is listed in the resource section in the Appendix.

You have two options for creating a Morel patch. The first is the simplest. Select a burnsite (campfire, fire-pit, bonfire site, etc.) that has had a fire in the past month and is well shaded. (Avoid sites where chemically treated wood, paper or plastics have been used.) Spade and mix the Morel spawn deep into the ashes and burnt wood. Heavily water the site and *ignore it* until early next April. If rain does not fall for more than 2-3 days in April and May, a few minutes of watering in the morning and evening can only help. Well water is fine. Do not use chlorinated water.

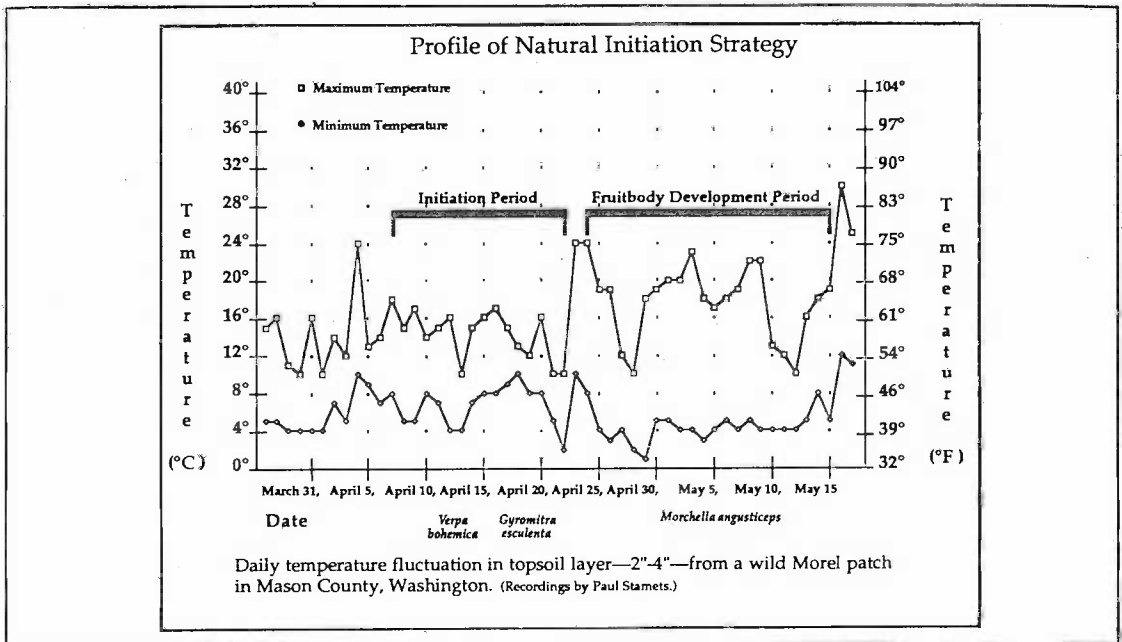

Figure 369. Temperature fluctuation for a period prior to, and during outdoor fruitings of Morels (*Morchella angusticeps*). Note that the temperature fluctuation for primordia formation occurred within 40-60° F. (5-15° C.)

**Available Strains:** Strains are readily obtained from wild clones or spore germinations. The mycelium out-races most competitors and can easily be isolated from contaminants.

**Mycelial Characteristics:** Mycelium at first fine, divergent, fast running, non-aerial and initially gray, soon thickening becoming gray-brown, with young clones developing numerous brown with orangish to golden nodules which I call "micro-sclerotia". (See Figure 361.) As the mycelium matures, the nutrified agar media becomes stained dark brown. (By viewing the petri dish cultures from underneath, the staining of the medium is clearly seen.) As cultures over-mature, the mycelium resembles squirrel's fur. When the mycelium is implanted into unsterilized wood chips, an powdery gray mildew forms on the surface. This asexual stage, resembling oidia, has been classified as *Costantinella cristata*. I do not see this expression on agar or grain media.

**Fragrance Signature:** Mycelium pleasant, smelling liked crushed, fresh Morel mushrooms. After transferring each jar of grain spawn, I am compelled to deeply inhale the residual gases still within each container. (A sure symptom of a Morel addict.)

**Natural Method of Cultivation:** Although my attempts to grow the White Morel (*Morchella esculenta*) indoors have only produced stunted mushrooms, I have had fairly consistent success at growing the Black Morels (*Morchella angusticeps*) outdoors in burned areas topped with peat moss or hardwood sawdust (oak or alder) supplemented with calcium sulfate. When Black Morel mycelium is dispersed into an outdoor burn-site, the cultivator relinquishes control to the natural weather conditions. In effect, *nature*

spawn throughout the depth of the substrate. Heavily water the site, provide shade and then institute the strategy of benign neglect—ignore it until early spring.

When Morel spawn is planted late in the year, between the months of October and December, the mushroom patch remains localized to the inoculation site. In contrast, Morel spawn that is planted in the spring often gives rise to fruitings remote from the inoculation site. A professor from the Portland State University planted her spawn in the early summer. The next spring she found a convoy of Morels fruiting from the site of inoculation extending several hundred feet along a walk-way. This also illustrates that, by locating your Morel patch in an area generally conducive to Morel growth, a substantially larger patch than one just 10 ft. x 10 ft. in size can be created. From my experience, the best sites, always shaded, are: around freshly laid wood chips of elm, oak, poplar, cottonwood and/or Douglas fir, in apple orchards, along gravel driveways, in washes from overflowing streams, and of course in soils where a fire has swept through. The greater the access to these types of favorable habitats that you give the Morel mycelium, the larger your potential Morel patch. The larger the mycelial mat, the more opportunities for widespread, underground sclerotia formation. Once the spawn is in place, you relinquish control over to natural forces. In effect, you allow Nature to do what it does best.

I have always envisioned, being the mad scientist at heart, of aerially bombarding prospective habitats with Morel sclerotia. Every time I see a television report of airplanes using a fire-retardant to quench a forest fire, I imagine their returning a week or two later and bombing the same sites with a sclerotial slurry of Morel spawn. I happily volunteer to be the spawn maker and the bombardier!

Outdoor Morel beds often support other mushrooms, some of which I view as “indicator” species. Their presence is a sure sign that the habitat is suitable for Morels. The most common and welcome indicator species are the brown cup fungi, species belonging to the Genus *Rhizina* (*R. undulata*), *Discina* (*D. perlata*) & the Genus *Peziza*, *P. phyllogena* (= *Peziza badio-confusa*).

Since I find Morels fruiting abundantly in amongst these cup fungi, I do not view them as true competitors. Furthermore, the False Morel, *Gyromitra esculenta* and the Early Morel, *Verpa bohemica*, precede Morels by two or more weeks. (See Chart, Figure 369).

In the Pacific Northwest, Morels are found directly at the base of cottonwood trees. A new hybrid strain of cottonwoods, a cross between eastern and western varieties, is being planted *en masse* for pulp production. The mating of these two varieties has yielded a “super strain” of cottonwoods, which grow up to an inch per day. These cottonwoods, with their accelerated life cycles, seem like ideal candidates for the companion cultivation of Morels outdoors.

A similar approach might work with apple trees. By locating an morel bed directly underneath apple trees, the cultivator could create a perennial Morel patch. Orchards, both small and large scale, could provide a bumper crop each spring. Once established, the Black Morel is well known to frequent the same apple orchard for decades. Most other habitats provide only a temporary home for Morels.

Since cottonwoods enjoy especially wet conditions, often unsuitable for pines, their soils are characterized as having a naturally higher moisture content. This environment is ideal for the natural cultivation of a number of many mushrooms outdoors, including those on logs and on chip/sawdust mounds. Mature cottonwoods can be harvested and inoculated with a wide variety of gourmet and medicinal mushrooms. Logs can be impregnated with Reishi (*Ganoderma lucidum*), Maitake (*Grifola frondosa*), Shiitake (*Lentinula edodes*), or Lion’s Mane (*Hericium erinaceus*) mycelium.



**Figure 375.** This mycological experimenter started a patch of Morels by simply broadcasting “M-11” spawn into a rocky debris field resplendent with burnt wood and upturned earth. Inoculated in November, a dozen or more Morels appeared in late March. Square pieces of paper indicate locations of Morel colonies.

Stumps, branches or log sections can be used for outdoor cultivation. (See Chapters 4 and 5.) Once mushrooms have fully produced on these wood substrates, the remaining material can be recycled for species sequencing, as fodder for animal consumption, as a base for mycofiltration, as a supplement for soil enhancement, or even as pulp for paper manufacturing. Mushroom mycelium naturally pulps the wood on which it grows. I believe the judicious combination of factors: mushroom strain, tree type and site location can be juxtapositioned to create a synergistic model for myco-forestry. Bear in mind that the ways of Nature are enigmatic. Some of these interactions may be far more complex than science can currently comprehend. I encourage readers of this book to explore these concepts and develop them further. This idea fits neatly into *Chapter 5: The Stametsian Model: Permaculture with a Mycological Twist*.

Leonard & Volk (1990) reported the co-occurrence of Morels (in the *M. esculenta* complex) fruiting with begonia plants (*Begonia tuberhybrida*). I have seen Morels growing with a variety of potted ornamentals, and in the

wild, with leeks. We know of no direct relationship between Morels and these lower plants—their co-occurrence may merely be coincidental. However, the direct association of Morels and certain trees like cottonwoods, elms, oaks, firs, and apples is consistent and long-term.

**Recommended Courses for Expansion of Mycelial Mass to Achieve Fruiting:** Currently the only successful method for indoor cultivation for any Morels is the one developed by Ower et al. (1986, 1988). However, I know of no skilled cultivators or professional mycologists who have been able to grow Morel mushrooms by precisely following the patented techniques. I am currently developing a method for *Morchella angusticeps* on cased rye grass seed but have only been successful to the stage where white “fuzz balls” emerge from a sea of brown mycelium. From the center of these fuzzy formations, finger-like Morel primordia form but abort due to some unknown environmental or genetic shortcoming. (See Figure 363.)

Morel mycelium can grow across nutrient agar media in a 100 x 15 mm. petri dishes in 3-4 days, and is clearly the fastest growing of all mushrooms. A conidial, or asexual stage, also develops from the mycelium wherein a spore is generated from the hyphal network and once germinated, produces more mycelia and more sclerotia. Soon after the Morel mycelium colonizes the surface of the

nutrified agar media, sclerotia form. The Black Morel produces a unique form of sclerotia, whose sheer numbers run into the thousands per cubic foot. These sclerotia resemble small golden nodules which eventually amass together. When they are broken during their early stage of development, many more sclerotia grow. Micro-sclerotia form abundantly on nutrified, sterilized media, especially MYA, OMYA and the many variations of these formulas.

When sawdust is inoculated with grain spawn, the sclerotia form most abundantly against the glass or plastic container, or along other interfaces. With most mushroom species producing these unique formations, sclerotia grow better in darkness than in light. (Heim et al. (1967), Stamets & Chilton (1983), Volk & Leonard (1990)). Although light can totally inhibit the formation of sclerotia in the *Morchella esculenta* group, strains of *Morchella angusticeps* are less affected.

Black Morel sclerotia amass as hundreds of small hardened, pumice-like structures which can become golf-ball sized. The sclerotia-forming ability is soon lost with continuously expanded mycelium. Only by using cultures close to their genetic origins is this sclerotia-forming ability preserved. When the mycelium declines in vigor, sclerotia are not only absent, but the mycelium changes into a mulatto form—cottony white mixed through golden brown, aerial mycelium. When cultures are transferred for more than ten generations of petri dishes (100 x 15 mm. dishes filled with MYA), the mycelium ceases to form micro-sclerotia. Clearly, maintaining stock cultures closest to their wild origins is critical for success in sclerotia production, and by inference, mushroom production.

Morel mycelium adapts to the liquid fermentation (Gilbert (1960) and injection techniques described in this book and in *The Mushroom Cultivator* (Stamets and Chilton (1983))). Sclerotia formation is substantially greater on annual rye grass seed than on coarser grains like rye, wheat or sorghum. Sclerotia from rye grass seed can be harvested after several weeks of incubation in low light or darkness.

**Suggested Agar Culture Media:** MYA, MYPA, PDYA, and OMYA. Volk & Leonard (1990) noted that *Morchella esculenta*, when grown on standard media preparations, notably Difco's PDA & Difco's Mycological Agar<sup>®</sup>, failed to form sclerotia spontaneously.

**1st, 2nd & 3rd Generation Spawn Media:** Rye grain for the first two generations. I prefer using soaked, annual rye grass seed for the 3rd or final generation, buffered with 5% calcium sulfate (by dry weight). Mix the rye grass seed and calcium sulfate together in dry form, submerge in water, at 2 times its make-up volume, and allow to sit overnight. Add 5 lbs. of moist hardwood sawdust into polypropylene bags. Place 1 cup (. 24 liters) of moistened rye grass seed as an even layer to the top surface of each sawdust-filled bag. Fold bags closed and sterilize for 2-3 hours at 15 psi. Inoculate the top layer with rye grain or liquid spawn. *Do not through-mix.* Incubate in low light and/or darkness for two weeks.

**Substrates for Fruiting:** When fully colonized and resplendent with sclerotia, take the above and invert the bags so that the seed layer is on the bottom. Place 4-6 inches of a moist layer of peat moss that has been buffered with 10% calcium sulfate (by volume) over the Morel seed/sawdust spawn. This concoction can be placed outside to benefit from natural spring initiation strategies or used in the attempt to grow Morels indoors. Note that separation of the seed from the substrate is not critical. The 10-12 inch depth from the bottom seed layer to the top surface of the buffered peat moss is sufficient



## Growth Parameters\*

### Spawn Run:

Incubation Temperature: 70-75° F.(21-24° C.)  
 Relative Humidity: 100%  
 Duration: 10-14 days  
 CO<sub>2</sub>: > 5000 ppm  
 Fresh Air Exchanges: 0-1 per hour  
 Light Requirements: n/a

### Sclerotia Formation:

Incubation Temperature: 60-70° F. (16-21° C.)  
 Relative Humidity: 90-100%  
 Duration: 20-30 days.  
 CO<sub>2</sub>: > 5000 ppm.  
 Fresh Air Exchanges: 0-1 per hour  
 Light Requirements: Darkness.

### Primordia Formation:

Initiation Temperature: 40-50° F. (4.4-10° C.)  
 Relative Humidity: 85-95% rH  
 Duration: 10-12 days  
 CO<sub>2</sub>: < 5000 ppm.  
 Fresh Air Exchanges: 2-4 per hour.  
 Light Requirements: 200-800 lux.

### Fruitbody Development:

Temperature: 40-60° F. (4.4-16° C.)  
 Relative Humidity: 85-95%  
 Duration: 10-20 days.  
 CO<sub>2</sub>: <5000 ppm.  
 Fresh Air Exchanges: 2-4 per hour  
 Light Requirements: 200-800 lux.

### Cropping Cycle:

One crop indoors. Spawn can be placed outdoors for creating natural patches.

---

to encourage Black Morel fruitbody formation. A fine layer (1 inch) of moistened vermiculite aids aeration. Since the physical separation of the the nutritional seed layer from the nutritionally poor peat moss is not necessary, this technique is uniquely different than those which have been patented by Ower et alia. The pH optima for fruiting falls between 6. 5-8. 0.

---

\* This is a proposed initiation strategy based on my observations of natural fruitings of the Morel and laboratory research with *Morchella angusticeps*, the Black Morel. This strategy will be amended and improved over time.

---

**Recommended Containers for Fruiting:** Tray of sufficient depth (10-12 inches) to accommodate the above with holes for drainage.

**Yield Potentials:** Estimating from the photographs of the indoor method used by Morel Mountain, yields appear to be in the 1 lb. per square foot range. Since Morels are hollow, the number of mushrooms per square foot weighs less than the same number of similarly sized solid mushrooms, for instance Shiitake.

**Harvest Hints:** Black Morels are best picked before the ridge edges become darkened and spores are released. When the mushrooms cease developing, the margins of the folds darken, wilt, and dry.

**Form of Product Sold to Market:** Fresh, dried, and powdered. Morel Mountain has fresh Morels year-round. Fungi Perfecti sells Black Morel spawn for outdoor inoculation. Their addresses are listed in the Resource section in the Appendix IV.

**Nutritional Content:** 20% protein (N x 4.38), 4.8% fat, 8.7% fiber, 64.4% carbohydrates. \*

**Medicinal Properties:** Not known to this author.

**Flavor, Preparation & Cooking:** A superb edible, this mushroom should be well cooked as many individuals are sensitive to it in the raw state. Morels work well in stir-fries and in a wide range of preparations. Please refer to the recipes in Chapter 24.

**Comments:** Morels can not be easily co-cultivated with other gourmet and medicinal mushrooms in the same growing room. Once a cultivator succeeds in getting to the stage of "white tuft" formation, humidity and temperature is critical for fruitbody development. (See Figure 363.) At this stage, a different set of environmental stimuli is introduced. I am proposing such a strategy in the above Growth Parameter section. Humidity levels should be lowered below the range specified for most mushrooms.

For more information, consult Ower (1982), Ower et al. (1986, 1988), Leonard & Volk (1992), Volk & Leonard (1989), Volk (1990), and Sanderson (1969).

---

\* This analysis based on *Morchella esculenta*. Taken from *The Biology & Cultivation of Edible Mushrooms*, ed. by Chang & Hayes, 1978.

# Maximizing the Substrate's Potential through Species Sequencing

**A**t our farm, I have found that the spent substrate generated in the course of Shiitake cultivation is in itself a valuable by-product. More mushrooms can be grown upon it! The mushroom cultivator can implement a circuit of recycling by sequencing species on the same substrate, resulting in the maximum yield of mushrooms imaginable. Each decomposer produces its own unique set of enzymes which can only partially break down a wood-based substrate. Once the life cycle of one mushroom has been completed, the life cycle of another species can begin on the same substrate utilizing its own unique set of enzymes, taking advantage of the remaining undecomposed wood fiber and the dead mycelium of the predecessor mushroom. After this second decomposer exploits the remaining lignin-cellulose to its fullest ability, a third species can be introduced. And so on. . . . I have been able to grow four species in sequence with this method. After several generations of mushroom

species, the mass of final substrate is a mere fraction of the original formula. The end material is reduced to a soft loam and is best used for compost or soil enhancement.

After running several species through the same substrate, Chang & Miles (1989, p.332) found that the net available nitrogen in the waste substrate actually increased, proportionately. Using cotton waste, the total nitrogen of the fresh compost waste was 0.63%. After the Paddy Straw mushroom produced on it, the residual nitrogen became 1.54%. After taking this same waste substrate and inoculating it with Oyster mycelium (*P. ostreatus* var. *florida*), the nitrogen increased to 1.99%. (The effect that spawn had on the substrate was not described. A 10% spawning rate with rye could substantially affect these figures. If "substrate spawn" was used, the net effect would be much less.) The end result of species sequencing is the production of a rich humus, ideal for gardening. This concept is further incorporated into the permaculture model described in Chapter 5.

The sequence of species introduction, however, is most important. The Shiitake model is the easiest to understand. After Shiitake mushrooms stop producing on supplemented sawdust/chips, the now-blackened blocks are broken apart until they resemble sawdust in texture. Calcium sulfate and/or carbonate enhance particle separation, drainage, and adjust the pH to the 6.5-7.5 range. (Try 1 cup of gypsum/chalk for every twenty blocks and adjust accordingly.) The type of wood initially used becomes the overriding factor affecting proper formulation. Water is slowly added until good moisture is achieved. I prefer a moisture content of 60-65%, less than the ideal 75%. Higher moisture contents often result in a higher percentage of bags spoiling due to fermentation

The now-moistened sawdust mixture is filled into polypropylene bags or other suitable containers, and sterilized. If water collects at the bottoms of the bags, then the substrate is too moist.

After sterilizing, the bags are inoculated according to the procedures in this book. I have found that Oyster mushrooms grow profusely on the waste Shiitake substrate with no need for amendment. King Oyster and Maitake also fruit, although 10% supplementation with rice bran or corn substantially improves yields. After the second species in sequence has run its course, the waste substrate is collected, re-mixed, sterilized, and finally inoculated with King Stropharia (*Stropharia rugoso-annulata*) or Shaggy Mane (*Coprinus comatus*). However, if the spent substrate is under-sterilized and/or too much water is added at make-up, contamination during incubation is likely. Keep in mind that waste substrates host far more microorganisms than fresh sawdust. Hence, sterilization may have to be prolonged to insure killing all the resident contaminants.

Each time one of the above species (except *Stropharia rugoso-annulata*) is grown through the sterilized, sawdust-based substrate approximately 10% of the dry mass (=25% wet weight) yields fresh mushrooms. Depending upon the species and many other variables, between 20-40% of the dry mass evolves into gases, mostly carbon dioxide, nitrogen, and ethylene. The first species, in this case Shiitake, easily produces 1.5 lbs. of mushrooms from the original 6 lb. substrate (75% moisture). At least 1.5 lbs. is lost through carbon dioxide evolution and evaporation. At the end of the Shiitake fruiting cycles, a 3 lb. waste substrate remains with a moisture content approaching 50%. After Oyster mushroom mycelium has taken its turn, the substrate un-

---

dergoes another 50% reduction in mass. Now, our sample has now been reduced from an original 6 lbs. to 1.5 lbs. At this stage, the remaining material, without supplementation, supports vigorous growth of the King Stropharia (*Stropharia rugoso-annulata*) or the Shaggy Mane (*Coprinus comatus*). Once colonized, the mycelium of these species are best used as spawn to inoculate outdoor substrates. At this final stage, the nutritional base of the substrate is largely expired, and subsequent fruitings are anemic.

In all, more than 20% of the substrate (dry weight to dry weight) is converted into edible mushrooms. At least that amount is liberated as gases. The remaining material can be added to garden composts as a supplement. The process of reduction/conversion is substantially prolonged if the cultivator utilizes large-particle wood chips in the original substrate formulas. If the waste wood substrate is further supplemented, the cycle can be extended.

This is but one path of species sequencing. Many others naturally come to mind. For instance, when production blocks of recycled Oyster, Maitake, Reishi (or others) have stopped producing indoors, they can be implanted outdoors into beds of sawdust. (Figure 339.) Additional fruitings arise from the buried blocks in 3-6 months, depending, of course upon the weather. I am always fascinated by the fact that these outdoor fruitings are often better than those indoors. Mushrooms seem to always

benefit when nature is used as an ally. The implanted blocks of mycelium have the ability to draw additional nutrients from the surrounding habitat. By launching the expired blocks from the growing rooms into supportive outdoor habitats, the cultivator maximizes the potential of the mycelial mass. One of my Natural Culture beds has supported a succession of three species—first Morels in the spring, then King Stropharia in the summer, and an assortment of *Hypholoma* and allied species in the fall. This approach could be called the Zen of mushroom growing.

Whatever path is chosen, the implications are profound. These courses of decomposition are occurring daily in our forests' ecosystems. Ecologists should also find this model especially fascinating in understanding the concurrence of many species living in the same habitat. This model may also be useful for those living in desert, island, or other environments where substrate materials for wood decomposers are costly and hard to acquire. I encourage all readers of this book to push these concepts forward with new innovations and applications, incorporating more sets of organisms. By understanding the nuances within the mycosphere, I envision the creation of complex biospheres wherein fungi play determinant roles in supporting other life cycles... I am not alone in believing that mushrooms could be instrumental in generating food for humans in the exploration of space.



## Harvesting, Storing, and Packaging the Crop for Market

**M**ushrooms can be compared to fish in their perishability. Once harvested, they are quick to spoil unless properly cared for. One advantage of growing gourmet and medicinal mushrooms is that, historically, they have been used in dried form for centuries. In Asia, more Shiitake is sold dried than fresh. Asians have found that the flavor of Shiitake is actually enhanced by drying. Further, having a readily available supply of dried mushrooms which can be stored for months at room temperature in airtight containers with no special care is very convenient for consumers. Compounded by the lack of refrigeration in many developing countries, dried mushrooms make good sense for both producers and consumers. In the United States, Canada, and Europe, more mushrooms are sold fresh than dried. In these markets, cultivators first supply the needs of the fresh market and then dry the surplus. Dried mushrooms can be sold as is or powdered for soup mixes, spices or teas.

## Harvesting the Crop

Simple guidelines prevail in the proper harvesting and storing of mushrooms. First, young mushrooms last much longer after harvest than aged mushrooms. Once spores have developed on the face of the gills, perishability is accelerated. If mushrooms have partial veils, like the Button Mushroom (*Agaricus brunnescens*) or the Black Poplar Mushroom (*Agrocybe aegerita*), they are best picked while the partial veils are intact, in other words when the mushrooms are still young. Partial veils protect the gills, limiting moisture loss, preventing spore release, and rupture only as the caps expand.

The cultivator must constantly counterbalance maximum yield with marketability. The comment I most often hear, after presenting my Oyster mushrooms to a distributor who has been purchasing them from afar, is "I didn't



Figure 376. Harvesting clusters of a cold weather, dark Oyster strain. This strain is popular in China and Japan.



Figure 377. Harvesting Paddy Straw mushrooms in Thailand.

know Oyster mushrooms could look like this!" Because Oyster mushrooms readily suffer from shipping and handling, local producers can easily usurp the markets of distant growers. Oyster mushrooms have a functional lifespan of only 5 days, after which marketability drastically declines.

Another rule is that clusters yield, pound for pound, higher quality mushrooms than mushrooms grown individually. Bouquets of mushrooms have obvious advantages, both from the point of view of harvesting as well as marketing. They can be picked with ease, needing minimum handling and trimming. Once harvested, the mushrooms protect one another by being bunched together. Harvesting mushrooms in clusters limits the damage caused by individual, loose mushrooms jostling against one another subsequent to harvest. Most importantly bouquets, at the ideal stage for harvest, are composed of





Figure 378. Bouquets of *Pleurotus ostreatus* are easy to harvest and have an extended shelf life. The bouquets usually snap off, originating from small, localized points of formation.

younger mushrooms. Mushroom bouquets can be sold much like broccoli. All these features combined extend shelf life far beyond that of individual mushrooms and make clusters highly desirable. All the gilled mushrooms de-

scribed in this book can be harvested as bouquets.

Each species passes through an ideal stage as the mushrooms mature. For most species, the ideal stage is when the caps are still convex, and before flattening out. At some magic moment in the maturity of a mushroom, the mushroom changes in its form while not appreciably increasing in its mass. Cultivators have long noted that the flesh of a mushroom at the "drumstick" stage is much thicker than when the mushroom is fully mature. The loss of flesh, directly above the gills to the top of the cap, appears to be re-proportioned to the expanding cap margin and the extension of the spore-producing gills. No real advantage, in terms of weight, is realized in picking a fully mature mushroom versus one that is a mature adolescent. In fact, mature adolescents store longer and taste better.

The ideal stage for harvest of each species is described in Chapter 21 under each species' growth parameters. Please refer to that chapter for helpful hints in harvesting. Since cropping is labor intensive, more efficient harvesting methods are always being explored. Cropping mushrooms in the most cost-effective manner largely depends on the structure of the fruiting frames. In Holland, mechanical harvesters have been devised to

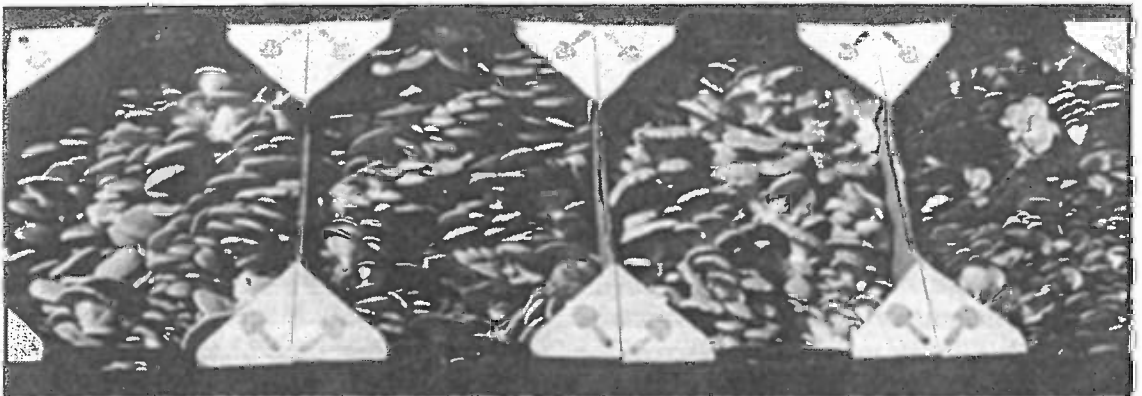

Figure 379. Four strains of *Pleurotus ostreatus*, in 5 lb. boxes, ready for delivery to restaurants.

harvest mushrooms from horizontal beds, eliminating the largest labor contingent in a mushroom farm—the pickers.

## Packaging and Storing the Crop for Market

Once mushrooms have been harvested, they must be quickly chilled. Most pickers at mushroom farms place mushrooms directly into open-grate plastic baskets which are frequently ferried to the cold room. The larger farms utilize blast chillers, which precipitously drop the temperature of the mushroom from room temperature to near freezing. A common mistake many growers make is to place their fresh mushroom directly into cardboard boxes after picking. Cardboard boxes insulate the mushrooms after harvest, essentially *preventing* them from being rapidly cooled. During or after cooling, mushrooms are sorted and packaged. Once cooled, the mushrooms must not be re-warmed until delivery. The ideal temperature for storage is 34° F. (1-2° C.). (See Lomax (1990) and Hardenburg (1986)).

Mushrooms are sorted according to markets to which they are destined. The Japanese are by far the connoisseurs of the world in terms of quality standards for marketing. So strict are their standards that many North American growers have been unable to penetrate the Japanese market. The Japanese also have the advantage of having a large pool of specialty growers who can coordinate their product lines to best fill their complex market requirements. Mushrooms are carefully graded according to type, size and form. Currently, in North America, the markets are relatively unsophisticated and the primary concern is for freshness. In the United States, a loosely adhered-to grading system is followed by some growers, buyers, and sellers. Number #1 Shiitakes are

usually 3-5 inches across, dark brown in color, with incurved margins, usually adorned with veil remnants. Number #2 are basically #1's which have more or less fully expanded. Number #2's are often lighter in color and exceed 4-5 inches in diameter. Number #3's show some damage, either to the gills or cap margin and are often deformed. Number #3's vary in size from tiny to excessive large mushrooms. I find it interesting that Americans, as a culture, have historically favored large mushrooms. Currently, in markets in San Francisco, large Shiitake are selling for several dollars per pound more than small ones.

Once mushrooms are sorted to grade, they are packaged for market. Restaurants generally prefer 5-7 lb. boxes. (See Figures 379.) Packages for consumers typically weigh 3, 5 or 7 ounces, a trick employed by many marketers to disguise the actual price per pound. (It's not easy for the consumer to divide 16 ounces (1 lb.) by 3, 5, or 7 to determine the actual price per pound.) In the United States, packages of fresh mushrooms should be small enough so that they can be grasped by one hand, and ideally retail at or below \$2.00. Once the sale price to the consumer exceeds the \$2.00 threshold, a precipitous decline in sales is seen. If every 3 oz. package sold for \$2.00, the retail price would be \$10.66 per lb. Most retailers consider a 40% mark-up fair. This gives the growers \$6.40/lb. at the wholesale level.

Another tactic commonly used with the Button mushroom is to sell the mushrooms loose in a tray, and have the consumers fill small paper bags imprinted with information on handling, cooking, etc... The consumer can be more selective in picking the mushrooms most desirable. However, every time the mushrooms are rummaged through, they suffer in quality. Although Button mushrooms are often sold

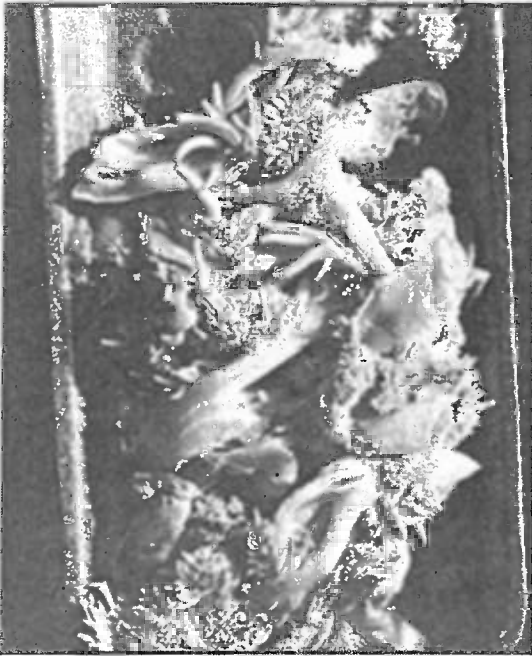

Figure 380. An example of poor packaging. Note mushrooms lie on Styrofoam base. They were covered with plastic. This package was photographed directly after purchase. This is the "sajor-caju" strain of *Pleurotus pulmonarius*. Thousands of primordia are forming on the adult mushrooms as they rot. Mushrooms in this condition, if eaten, cause severe cramping, diarrhea, and gastro-intestinal discord.

loose, the gourmet mushrooms, being more fragile, are best sold packaged.

Covered with clear, anti-condensate, breathable plastic, mushrooms can be preserved for extended periods of time. A patent was awarded to Asahi-Dow Ltd. for a vapor-permeable film specifically designed for extending the shelf of Shiitake. (See Japanese Patent # 57,163,414 (82,163,414)). The rate of diffusion of carbon dioxide giving the best results was within 5000-40,000ml./sq. m. at atmospheric pressure over 24 hours. The optimal range of oxygen diffusion was 2000-20,000 ml/m<sup>2</sup> at atmospheric pressure in 24 hours. This new generation of

anti-condensate, gas-permeable films must be carefully matched with a cardboard base or strawberry-like basket. Even with shelf life being extended, mushrooms should be rotated through stores at least twice weekly to ensure the highest quality product. Oyster mushrooms in particular are quick to spoil.

The greatest insult to marketing gourmet mushrooms can be seen by vendors who buy large quantities of Oyster mushrooms from production factories whose main concern is yield, not quality. Oyster, Enoki, and other mushrooms, when they spoil, cause severe abdominal cramping, nausea, and gastrointestinal upset. (See Figure 380.) Once customers have experienced these "gourmet" mushrooms, they are unlikely to ever buy them again. Remember, mushrooms are first suspected and first blamed for any type of food poisoning, whether they are at fault or not. (For more information on the proper handling of mushrooms after harvesting, please consult Murr & Morris, 1975.)

## Drying Mushrooms

By drying mushrooms, cultivators recapture much of the revenue that would otherwise be lost due to over-production. Most mushrooms are approximately 90% water. Reishi mushrooms, being woody in texture, are usually between 70-80% water. When Shiitake are grown outside, especially in the Donko (cracked cap) form, moisture content is often only 80%. When mushrooms are young, moisture contents are usually higher than when they are mature. Mature mushrooms, with their gills exposed, dry faster than young, closed mushrooms.

Shiitake, Oyster, Morels, Reishi, and many other mushrooms dry readily and can be stored for many months. Mushrooms can be sold in their

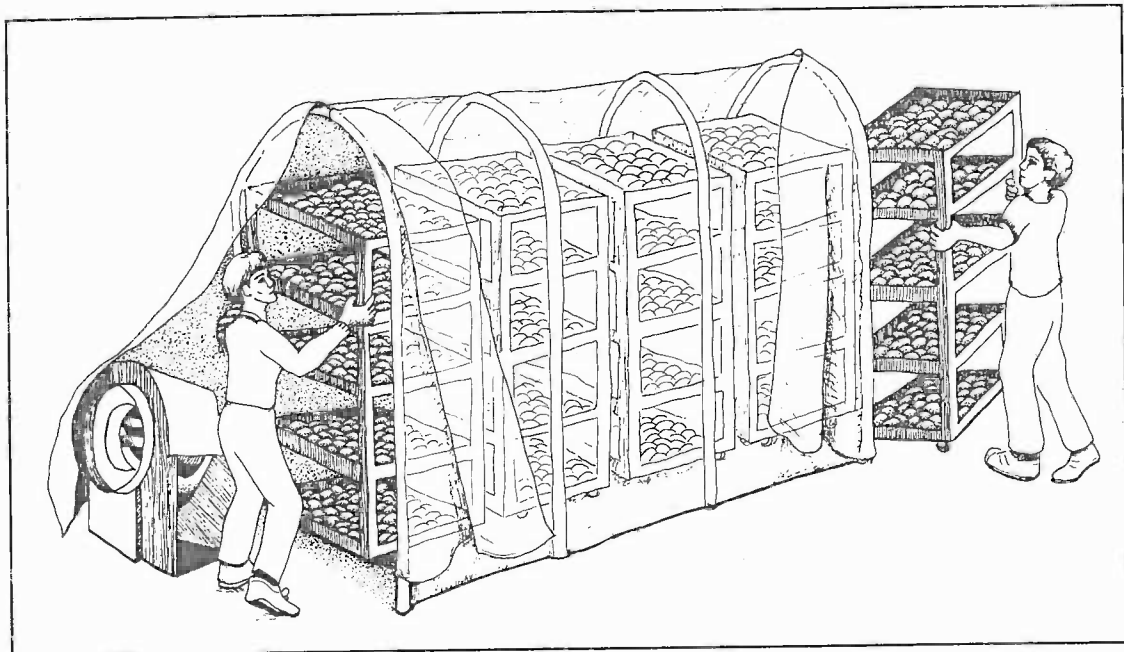

Figure 381. A commercial dehydrator utilizing a large volume of air to remove moisture from mushrooms. Fresh mushrooms are placed onto screened shelves on wheeled racks, entering the drier downstream from the drying mushrooms. Hundreds of pounds of mushrooms can be dried at one time, inexpensively.

natural form or powdered for soups, spice mixtures, teas, etc. Some cultivators actually sterilize their dried mushrooms, without harm, to prolong storage. Sterilization assures that no bacteria, insect eggs, or other microorganisms consume the crop during storage. Once dried, the mushrooms should be hermetically sealed, and ideally *frozen* until needed.

Many types of dehydrators can be used for drying mushrooms. The smallest are those also marketed for home use in the drying of fruits, meat, and fish. For most growers, home dehydrators have insufficient capacity so many fashion their own dehydrators. Window screens can be stacked within a vertical framework, 3-4 inches apart. At the bottom, heat lamps or an electric coil, are positioned. Ample air inlets are located near ground level. The vertical frame-

work is solid save for a hinged door on one face which allows easy insertion and retrieval of trays. A fan is located at the top, drawing air out of the dehydrator. This arrangement insures a chimney effect whereby heated air is drawn through the bottom and exhausted out the top. The humidity of the incoming air greatly affects the efficiency of this type of dryer. Some growers locate their dryers in hot rooms, typically low humidity greenhouse-like environments, which helps the drying process.

The best commercial dryer I have seen is also the simplest. Mushrooms are placed onto trays and stacked into vertical racks equipped with wheels. The wheeled racks are inserted into a large plastic wind tunnel. (See Figure 381.) The plastic wind tunnel can be kept inflated by hoops of plastic pipe and through the force of

a large blower located at one end. Trays with fresh mushrooms are moved into the wind tunnel furthest downstream. The fully dried mushrooms are retrieved through an overlapping "flap-door" nearest to the fan. For most cultivators, this type of commercial dehydrator does not require a heat source. The huge volume of air removes the moisture through evaporation.

Depending upon the species and the final product desired, mushrooms can be placed gills down or gills up. By placing Shiitake mushrooms with their gills down, the mushrooms remain flatter in drying and take on a more brittle texture. Most experienced Shiitake growers find that by drying mushrooms, gills facing up, that the cap curls inwards, giving the mushroom an overall tighter and more resilient texture. This form is the one most recognized by Asians.

Dried mushrooms are then packaged, sometimes shrink-wrapped into plastic bags, and usually sold in 3–5 ounce packages. In most cases, the shelf life of dried mushrooms is about a year. If there is any danger of fly larvae or insect infestation, low pressure steam sterilization is recommended.

## Marketing the Product

In the United States, markets for fresh mushrooms have surged over the past 30 years, from a total market value of \$68,000,000 in 1969 to \$665,000,000 in 1992. Fresh gourmet mushrooms were virtually unavailable in 1980. In 1992, gourmet mushrooms represented \$17,000,000 of total fresh mushroom sales, a 22% increase over the same period from the previous year. The average price for Shiitake in 1992 was \$4.11 per pound and Oyster mushrooms sold for \$3.66 per pound. (Approximately four times as many Shiitake are sold in this country than



Figure 382. 10-kilogram bags of dried Shiitake displayed for sale in a market in China.

Oyster mushrooms.) In comparison, the average price for Button mushrooms for the same period was an astounding \$.87 per pound. The upward trend in terms of price, production, diversity and markets is expected well into the future.\*

Before producing mushrooms on a commercial level, the cultivator is advised to conduct mini-trials. With a little experimentation, the cultivator can refine his techniques. Each failure and success is useful in determining the proper mushroom strain, substrate formula, temperature tolerance, lighting level, harvesting methods, and marketing strategies. Note

\* Data derived from *Mushrooms*, August, 1992, Agricultural Statistics Board, National Agricultural Statistics Service, United States Department of Agriculture, Washington, D.C. See Resource section in the appendix.

that yields from mini-culture experiments often exceed average values from commercial scale operations. I strongly encourage cultivators to increase their production levels slowly, and according to their skills in both mushroom technology and business management.

A number of organizations help growers find markets for their mushrooms. Some co-operative marketing organizations coordinate production and sales. Co-op marketing becomes a necessity when multiple growers overwhelm local markets. (Refer to the Resource Guide, Appendix IV for a list of some marketing organizations.) The United States Department of Agriculture can sometimes assist growers in contacting marketing outlets.

I am a strong believer in growing mushrooms organically. Once certified organic, local producers can sell mushrooms to natural food co-ops and some up-scale grocery chains for a premium. The restaurant trade, from my experience, seems little impressed whether or not the mushrooms are organically grown. In either case, the key to the financial success of a mush-

room farm centers on its ability to market mushrooms successfully. The person in charge of marketing must foster a close, professional relationship with the buyers.

In Asia, marketing gourmet mushrooms has benefited from a long tradition while in North America gourmet mushrooms are a relatively new phenomenon, having been available for less than twenty years. (See Farr, 1983.) With more growers coming into production, the markets are likely to fluctuate in response to the sudden increase in the availability of mushrooms. Cycles of over- and under-production are typical in any new, expanding marketplace and should be expected. Growers must adapt their production schedules and product lines so they do not become over-extended. As the public becomes increasingly aware of the health stimulating properties of mushrooms, markets should expand enormously. Those growers who are able to survive this early period of market development will become key players in an industry that is destined to become a centerpiece of the new environmental economy.

# Mushroom Recipes: Enjoying the Fruits of Your Labors

**V**ersatile, tasteful, and nutritious, gourmet mushrooms enhance any meal. Multi-dimensional in their flavor qualities, mushrooms appeal to both vegetarians and meat-eaters. The following recipes can be used with almost any of the mushrooms described in this book. The simplest way to prepare gourmet mushrooms is in a stir-fry at medium high heat with a light oil, frequently stirring. Other ingredients (onions, garlic, tofu, nuts, etc.) can be added after the mushrooms have been well cooked.

Here are some of the favorite recipes from notable mushroom dignitaries. I hope you enjoy these recipes as much as I have. For more recipes, please consult the references listed at the end of this chapter. Bon Appetit !!!

### David Arora's *Mediterranean Mushroom Recipe*

Choose the meatiest caps of King Stropharia (young), Oyster, Hon-Shimeji or Shiitake mushrooms, lightly salt the gills, and dab them with olive oil. Stuff slivers of shallots or garlic between a few of the gills. Broil or grill the mushrooms over hot coals for a few minutes on each side, until tender. "Nothing could be simpler or more delicious," according to David.

### Arleen & Alan Bessette's *Dragon's Mist Soup*

- 1 tblsp. vegetable oil
- 1 1/2 cups water
- 4 cloves garlic, finely minced
- 1/2 cup bamboo shoots, drained, rinsed, cut into 2-4 inch pieces.
- 2 tblsp. soy sauce
- 1/4 tsp. white pepper
- 5 oz. tofu (cut into 1/2 in cubes)
- 1 can (14 1/2 oz.) chicken broth
- 2 scallions w/tops, minced
- 1 cup thinly sliced, fresh Shiitake mushrooms
- 1 tsp. salt
- 1 tsp. sesame oil

In a sauce-pan, saute mushrooms in 1 table-spoon vegetable oil over medium-low heat for approximately 5 minutes. Add broth, water and garlic; bring to a boil, reduce heat and simmer 10 minutes. Add all remaining ingredients except sesame oil. Return to boil, reduce heat and simmer 5 minutes. Just before serving, stir in sesame oil. Serves four.



Figure 383. Our family prefers to tear Shiitake rather than cutting. This preserves flavors and minimizes damage to the cells.



### Jack Czarnecki's *Shiitake in Burgundy Butter Sauce*\*

1/2 cup chopped onions  
 1 cup water  
 1/2 tsp. ground chili powder  
 1 tsp. lemon juice  
 1/4 cup red wine  
 1 tsp. sugar  
 1 lb. fresh Shiitake caps  
 3 tblsp. melted butter



1/2 tsp. ground coriander  
 1 tsp. fresh, crushed garlic  
 1/4 tsp. ground black pepper  
 1 tsp. salt  
 1 tblsp. soy sauce  
 1 1/2 tblsp. cornstarch  
 w/1/3 cup water

In a skillet, saute the onions in the butter until transparent, then add water. Add the other ingredients, except the mushrooms and cornstarch, and stir for 1 minute. Add the mushrooms, and turn the heat to low. Cover the skillet with a tight-fitting lid, and let simmer for 30 minutes. Thicken the mixture with the cornstarch-and-water mixture, and serve alone or over rice. According to Jack, the sauce actually enhances the flavor of the Shiitake. Makes 4 servings.

### Jack Czarnecki's *Chicken with Oyster Mushrooms*\*

1 1/2 cups heavy cream	1/2 cup chicken stock
1 tblsp. cream sherry	1 tsp. fresh, crushed garlic
1 tblsp. prosciutto	1 tblsp. onion, chopped finely
12 ounces cooked chicken or turkey meat from breast cut into 2 inch strips	1/2 lb. oyster mushrooms sliced into 2 in. strips
2 tblsp. cornstarch mixed with 1/3 cup water.	salt & pepper to taste

Combine all the ingredients except the cornstarch mixture in a heavy skillet. You may also want to save the salting until the dish is slightly heated. Heat until simmering over a medium flame, then continue simmering over a low flame for 5 minutes. Thicken with the cornstarch-and-water mixture, and adjust for salt as necessary. Serve hot.

\* Gratefully reprinted, with permission of the author, from *Joe's Book of Mushroom Cookery*, 1988 Atheneum/Macmillan Publishing Co., New York, N.Y.

### Larry Lonik's *Morel Quiche*

*Gratefully reprinted, with permission of the author,  
from The Curious Morel: Mushroom Hunter's Recipes, Lore & Advice.*

1 pound Morels	1/4 bacon (or "bacon bits")
1/2 cup chopped onion	1/2 cup chopped green pepper
1 1/2 cups shredded baby	1 1/2 cups milk
Swiss cheese	3 eggs
3/4 cup Bisquick™	1/4 teaspoon pepper
1 teaspoon salt	

Preheat oven to 400° F. (200 +° C.). In a 10 inch lightly greased pie pan mix bacon, mushrooms, onion, green pepper and cheese. In medium-sized bowl add milk, Bisquick™, eggs, salt and pepper. Beat until smooth. Pour into pie pan. Bake 35-40 minutes or until inserted toothpick comes out clean.

### Irene & Gary Lincoff's *Pickled Maitake (Hen-of-the-Woods)*

*(The Lincoffs wish to thank Jean-Paul & Jacqueline Latil for this recipe.)*

Marinade: 1 cup white wine (dry)	a few slices of onion
1/3 cup olive oil	a few sprigs of parsley
Juice from 1 lemon	a few cloves of garlic

Season marinade with salt, peppercorns, bouquet garni, or other preferred spices. After cleaning the mushrooms, and separating the "leaves" of Maitake in bite-size pieces, throw them in boiling water for 2 minutes, drain, and let cool on paper towels. Bring marinade to a boil and cook the mushrooms in the marinade until done to taste (crunchy to soft). Remove mushrooms. Discard solids from marinade. Store mushrooms, covered with marinade, in glass jars, with a thin layer of olive oil on top to help preserve. Store refrigerated.

---

---

### Hope & Orson Miller's *Hot Mushroom Dip Especial*

- |                                 |  |
|---------------------------------|--|
| 1 lb. fresh mushrooms*          |  |
| 1 tblsp. lemon juice            | 2 tblsp. minced onion  |
| 1 lb. carton low fat sour cream | 2 tblsp. soft butter or margarine                              |
| 2 tblsp. flour                  | 2 vegetable or chicken bouillon cubes ( or 2<br>tsp. granules) |
| 6 tblsp. butter                 |  |

Chop mushrooms quite fine and saute in pan

with butter and lemon juice. Let simmer 5-10 minutes. Add onions, sour cream, bouillon granules, salt, and pepper. Simmer 5-10 minutes more. Make a paste of the remaining butter and flour. Add to hot mixture and stir until thickened. Serve hot, in fondue pot or chafing dish, with chips, crackers, or fresh vegetables. (Note: if thickened with seasoned bread crumbs, fresh dill may be added as filling for Mushroom Squares. Use crescent roll dough. Pat the dough into a small 9 inch pan, spread filling and cover with more dough. Bake 20-30 minutes at 375° F. Cut into squares and serve hot.) Hope has prepared and served this dish to the kudos of mycologists throughout the world.

\* Morels/Lion's Mane/Shiitake, or Shimeji. Gleaned, with permission of the author, from a book entitled *Hope's Mushroom Cookbook*, 1993, Mad River Press by Hope Miller.

### Scott & Alinde Moore's *Cheese-Mushroom Quiche*

- |                                |   |
|--------------------------------|---|
| 1 1/2 cups grated Swiss cheese |   |
| 1 medium onion, chopped        | 4 eggs                                      |
| 1/4 lb. mushrooms, chopped     | 1 1/2 cups milk                             |
| Dash of salt, pepper, & thyme  | 3 tbsp. flour                               |
| 1/4 tsp. salt                  | Prepare single pie crust. Cover bottom with |
| 1/4 tsp. dry mustard           |   |

1 1/2 cups grated Swiss cheese. Meanwhile, sauté in butter, onions, mushrooms, salt, pepper, thyme. Add to cheese in pie crust. Beat together the remaining five ingredients and pour over mushroom layer in pie crust. Sprinkle with paprika. Bake at 375° F. (190° C.) for 40-45 minutes, or until center in firm.

*Maggie Rogers' Oyster Mushrooms  
with Basmati Rice & Wild Nettles*

1 1/2 cups chopped Oyster (or Shimeji)	1 tblsp. butter
1 medium green onion, sliced thinly	1 tblsp. olive oil
1/4 cup celery, sliced thinly	1/4 cup carrot, chopped
1/4 tsp. basil	1/4 tsp. thyme
1/4 cup very dry sherry	1 cup cooked turkey breast, chopped
2 tblsp. flour or 1 tblsp. cornstarch	1/2 cup cold water
1 cup half & half cream	6 dozen nettles or 1 loose, full grocery bag

From Maggie's notes: At the time you're finding spring Oyster mushrooms, the wild nettles are about to flower and ready for picking. Use leather gloves or native wisdom to keep from getting stung. Break off just the top three leaf levels of each stalk. Prepare them by rinsing in cold water, steaming over boiling water for 7 minutes and lightly salting and peppering them. (You can pick nettles in the spring, blanche for 6 minutes, and freeze several packages for future use.) If served as below, no melted butter is needed; they have their own flavor.

Saute Oyster (or Shimeji) mushrooms in butter or olive oil with onion, celery and carrots. Let simmer in its juices for 10 minutes or until slightly reduced. Add basil, thyme, sherry, turkey bits, bouillon granules and simmer for another 10 minutes. Taste, add salt and freshly ground pepper as needed.

Make a thickening of the water and flour (or cornstarch). Stir in slowly and let simmer for another 5 minutes or more, or until thickened, stirring occasionally.

Just before serving, add the half & half, simmer for 5 minutes or so, then pour into a warmed bowl. Serve over Basmati rice, fluffy white rice or lightly toasted sourdough bread cubes. Serve with steamed wild nettles or freshly steamed asparagus on the side and a clear light wine. "Friends will chirp with satisfaction once they get over the wildness of it all."

---

---

## Robert Rosellini's *Broiled Rockfish in an Oyster or Shimeji Mushroom & Ginger Sauce*

*The following recipe uses a yellow-eye rockfish from the Pacific Northwest which is firm and delicately textured with a low fat content. The absence of fat in this particular fish provides its "clean" and pure quality. The following recipe is quick, simple, and easy for home preparation.*

6 oz. of filet of rockfish	1 oz. white wine
1/4 lb. fresh, thinly sliced	1 oz. sweet butter (salted)
Oyster or Shimeji	1/2 oz. preserved ginger

Brush the filet of fish with oil and broil (or bake at 450° F.) until the translucent flesh turns opaque (7-10 minutes). Remove fish from broiling pan, place the same pan on oven burner at high heat, and de-glaze pan with white wine. When wine has been reduced by 2/3, add sliced mushrooms and preserved ginger. Saute for about 1 minute, add butter, and swirl ingredients together until butter forms a smooth texture (about 16-20 seconds). Remove immediately and pour over fish filet.

Note: Achieving the smooth texture with butter requires practice to avoid breaking the butter. Once this simple technique is accomplished, there are many variations of this recipe procedure. Butter contains half the fat content of most oils, and thus these recipes should be consistent with low fat dining strategies. Bon Appetit!

## Cruz Stamets' *Mushroom Sauté Supreme*

1/2 lb. fresh Shiitake	2 tablespoons pesto
1 tarragon sprig	1 thyme sprig
1/2 cup canola oil	1/4 cup olive oil
3 garlic cloves	1 small onion, diced
1/8th cup water	2 tblsp. shaved almonds

Trim and discard stems of Shiitake, dice upper part of stems into small pieces, and put aside. Discard lower stems. Then tear each Shiitake mushroom into six or more pieces. In medium size skillet using 1/2 cup canola oil, bring heat up to high, then add mushrooms. Cook Shiitake until golden brown on each side. Add pesto and olive oil. Lower heat to medium, add diced onions, tarragon, thyme, garlic, almonds, and water. Salt and pepper to taste. Simmer for five to ten minutes. Once cooked, this mixture can be:

- 1) mixed into white or wild rice.
- 2) mixed into pasta.
- 3) placed on top of salmon or white fish.
- 4) mixed in with tofu and cooked.
- 5) mixed into a quiche and baked.

### *Cruz Stamets' Fresh Shiitake Omelet*

1/2 cup cashews

1/2 small onion

2 garlic cloves

8 eggs

salt & pepper to taste

1/2 lb. fresh Shiitake

1 cup grated cheddar cheese

2 tblsp. tamari

1/4 cup water

2 tblsp. canola oil

Mix the eggs and water in a large bowl and beat thoroughly. Saute mushrooms in frying pan with oil until water is cooked-out. Add onions and garlic, cook for one minute then add cashews. In medium sized skillet, spray a thin coat of oil or butter, add egg mixture and cover for 1 minute. Add layer of cheese. Pour mixture that includes Shiitake, onions, cloves, etc. . . over layer of cheese. Fold over and cook for 2-3 minutes. Makes four servings.

### *Larry Stickney's Morel Creme Superieur*

1 pint to 2 pints of heavy cream

2-3 tblsp. butter

1/2 lb (or more) fresh Morels (cut into 1/4 in. cartwheel sections)

Warm cream over a camp stove or wood fire in a small pot. Do not let cream burn onto the pan's bottom. When the cream simmers, place the sliced Morels into pot with butter, and remain until cream returns to a simmer for at least 5 minutes. Morels should not become limp before tasting, using toothpicks or forks to retrieve them. After the last Morel is removed, Larry notes, that lots must be drawn to determine the lucky soul who has the privilege of downing the heavenly, rich, spore darkened cream soup.

Larry's recipe is quick and easy, ideal for tasting Morels at primitive campsites during remote Morel forays in the mountains. "Only the medically forbidden should entertain thoughts of dietary restraint during the brief Morel season when long hard hours in the forest set up a healthy appetite in the wake of massive calorie burning and likely liquid deprivation. . . . Delectation is soon at hand." He makes no note for those athletically inclined Morel cultivators who must walk from their house to their backyard to harvest Morels. Presumably, the same advice holds.



### *Andrew Weil's Shiitake Teriyaki*

1 cup dried Shiitake	1/4 cup sake
1/4 cup shoyu	2 tblsp. light brown sugar
2 chopped green onions	a few drops (roasted) sesame oil

Reconstitute 1 cup dried Shiitake by covering with hot water and let stand till caps are completely soft. (Or cover with cold water, microwave on high for 2 minutes and let stand.) Cut off and discard stems. Squeeze excess liquid from caps and slice into 1/4 inch pieces. Place pieces in saucepan with 1/4 cup sake, 1/4 cup soy, and 2 tblsp. light brown sugar. Bring to boil and simmer, uncovered, till liquid is almost evaporated, tossing mushrooms occasionally. Remove from heat, cool, and chill. Sprinkle with finely chopped green onions and a few drops of dark (roasted) sesame oil. Serve as appetizer, side dish, or over rice.

### *Additional Recipes*

#### *Shiitake or Maitake Clear Soup*

2 tblsp. miso	1/2 oz. dried mushrooms
1 1/2 cups mushroom broth	(or 1/4 lb. fresh mushrooms)
2 cups water	1 tub tofu
1/4 - 1/2 cup chopped onions	1 tsp. soy sauce

Soak cut or broken mushrooms in 2 cups cold water for 15 minutes. Drain off broth and save. Cover mushrooms with more cold water and soak for another 20 minutes. Add saved mushroom broth back into preparation and boil it for a few minutes. Season soup with soy sauce and miso. Add chopped tofu, onions and/or other vegetables. (If needed, add 1-2 cups more water.) Bring back to a boil for 1-2 minutes and turn down heat. Allow to simmer for 5 minutes. Serves four people.

---

---

### *Shiitake Hazelnut Vegetarian Pate\**

*\* Credit for this recipe is gratefully given to Timmer, Pershern & Miller's "Cooking American with an Oriental Favorite: Recipe Development with Shiitake Mushrooms" from Shiitake Mushrooms: A National Symposium Trade Show, University of Minnesota Center for Alternative Plant and Animal Products College of Natural Resources, College of Agriculture, St. Paul, Minnesota, May 3-5, 1989.*

4 oz. Shiitake Mushrooms	1/8 tsp thyme
3 tblsp. butter	1/4 tsp. salt
1 clove garlic, minced	1/8 tsp. pepper
1/4 cup toasted hazelnuts	2 tsp. dry sherry
3 oz. Neufchatel cheese	1 tsp. fresh parsley leaves

Trim and discard woody ends from mushrooms. In a food processor, finely chop mushroom caps and stems. In medium skillet, melt butter. Add mushrooms and garlic and saute for at least 5 minutes. Stir in thyme, pepper, and salt. In food processor, chop parsley. Add hazelnuts and process. Add Neufchatel cheese and process until smooth. Add sherry and mushroom mixture. Process until well mixed. Spread or mold in serving dish. Cover. Chill at least 1 hour. Serve with crackers. Yield: 1 cup. Other mushrooms can be substituted for, or combined with Shiitake. My variation on this recipe is to first sauté the mushrooms before adding them to the food processor.

### *Maitake "Zen" Tempura*

1 oz. . dried Maitake or 1/3 lb. fresh Maitake	1/3 lb. flour (2 cups)
1/2 cup cold water	2 eggs
vegetable or canola (rape seed) oil	tempura sauce

If using dried Maitake, soak cut or broken mushrooms in 2 cups cold water for 15 minutes. Discard water. Cover mushrooms with more cold water and soak for another 20 minutes. Drain and discard water. In a separate bowl, mix flour with eggs and cold water. Dip and roll the mushrooms into the flour/egg mixture. Deep fry the Maitake mushrooms in hot oil (356° F. = 180° C.) for one minute. Remove any damp excess oil with paper towel. Serve with tempura sauce. This recipe can also be used as a base to make tempura shrimp, white fish, and/or assorted vegetables such as zucchini, potato's, onions, etc.

---

---



## Recommended Mushroom Cookbooks

*A Cook's Book of Mushrooms* by Jack Czarnecki, 1995. Artisan Books, Workman Publishing, New York.

*Edible Wild Mushrooms of North America: A Field-to-Kitchen Guide* by David W. Fischer and Alan E. Bessette, 1992. University of Texas Press, Austin, Texas.

*Hope's Mushroom Cookbook* by Hope Miller, 1993. Mad River Press, Eureka, California.

*Joe's Book of Mushroom Cookery* by Jack Czarnecki, 1988, Atheneum, New York.

*Mushroom Cookery* by Rosetta Reitz, 1945, 206 pgs. Gramercy Publishing Co., New York.

*Mushrooms: Wild & Tamed* by Rita Rosenberg, 1995. Fisher Books, Tucson, Arizona.

*Taming the Wild Mushroom: A Culinary Guide to Market Foraging* by Arleen Rainis Bessette and Alan E. Bessette. University of Texas Press, Austin, Texas.

*The Mushroom Feast* by Jane Grigson, 1975. Alfred Knopf, New York.

*Wild about Mushrooms for Foresters & Feasters*, by Louise & Bill Freedman, 1987. Addison & Weseley, 1987.

*Wild Mushroom Cookery* ed. Mike Wells & Maggie Rogers, 1988, The Oregon Mycological Society, Portland, Oregon.

---

---



# Cultivation Problems & Their Solutions: A Trouble-Shooting Guide

**T**his trouble-shooting guide should be used in conjunction with the Species Growth Parameters in Chapter 21 and the Six Vectors of Contamination described in Chapter 10. Individual contaminants are not specifically characterized in this book. If the vector introducing contamination is blocked, using the techniques described here, the competitor organisms are effectively stopped. For extensive descriptions on contaminants, please refer to *The Mushroom Cultivator* by Stamets & Chilton (1983) and *The Pathology of Cultivated Mushrooms* by Houdeau & Olivier (1992).

The following guide lists the most frequently encountered problems, their probable causes, and effective solutions. A combination of solutions can often solve problems whose causes can not be easily diagnosed. Most can be prevented through process refinement, structural re-design, improvement in hygiene maintenance, and/or replacement of personnel. Most importantly, the manner of the culti-

vator has the over-riding influence on success or failure. I strongly encourage that, at every stage in the cultivation process, the cultivator leaves one petri dish, spawn jar, sawdust bag, etc. *uninoculated* to help determine whether or not ensuing contaminants are unique to the media preparation process versus the inoculation method. These “blanks” are extremely helpful in diagnosing the probable vector of contamination.

Cultivators should note that when one error in the process occurs, many symptoms can be expressed. For instance, diseases attacking mature mushrooms are to be expected if the humidity is maintained at too-high levels during cropping. If the growing room is kept at 100% rH, the surfaces of the mushrooms remain wet and become perfect environments for parasitic fungi and bacteria. Bacterial blotch attacks developing mushrooms. Green molds proliferate. Mites eat mold spores. Flies carry mites and spores. If these organisms spread to developing primordia, massive deformation and contamination ensues. Those mushrooms which do survive have exaggeratedly short shelf lives after harvest. So, in this instance, one problem—humidity being too high—results in multiple symptoms. The lesson here: what is good for one contaminant is good for many! Controlling the vector of contamination must be coupled with creating an environment more conducive to the growth of mushrooms than competitors.

Population explosions of *Sciarid* and Phorid flies defeat Oyster mushroom cultivators more than any other competitor. Fly control measures have ranged from simple sticky pads to the use of pesticides, a recourse I abhor. The use of pesticides, although rampant with many “old school” cultivators, is totally unnecessary for gourmet and medicinal mushroom cultivation—given a balance of preventative measures. Bug lights should be positioned at the entrance of every door. The bug traps I find that work the best are those which feature a circular black light and centrally located fan that creates a negative pressure vortex, features which greatly extend their effective range. These bug lights should also have sticky pads affixed below them that trap “fly-bys” or “near-misses”. (See Figure 384). Coupled with the frequent washing down of the growing room, at least twice a day, population explosions can be forestalled or precluded.

There is one final control measure I recommend highly and which occurred naturally in our growing rooms. For the past 5 years, our growing rooms have sustained a population of

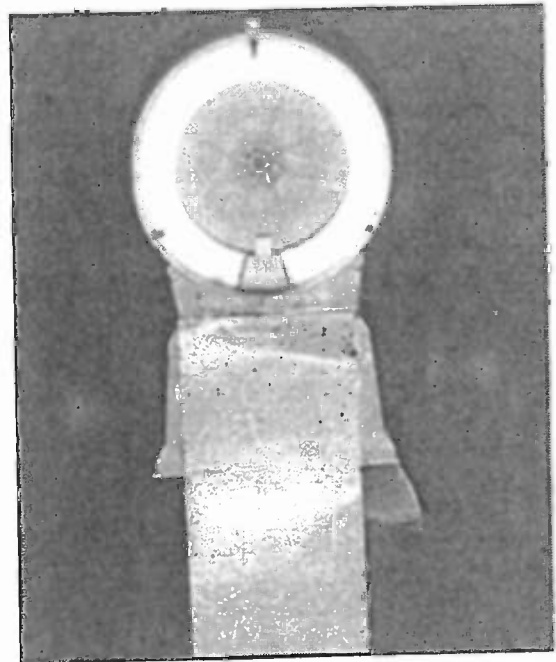

Figure 384. A highly effective bug trapper. The circular light attracts flies to the vacuum-vortex which throws the flies into a clear plastic bag. By attaching “sticky paper” underneath the light, hovering flies are also captured. The clear bag allows the easy, daily counting of flies, and helps predict impending outbreaks.

small tree frogs. The only food source for the frogs, which have ranged in number from 2 to 8 in a 1000 square foot growing room, are flies. (See Figure 385.) Each frog consumes between 20-100 flies per day and often perch upon mushrooms. The growing rooms—with their resident flies and frogs—are in a state of constant biological flux, re-adjusting to maintain a delicate equilibrium. When the fly population declines, so do the frogs, and vice versa. An unexpected added, and purely aesthetic benefit: the frogs chorus at night with a mesmerizing resonance that brings joy to my heart. I consider these frogs to be faithful guardians, deserving respect for their valiant efforts at fly feasting, an activity which has an immediate beneficial impact in protecting the mushroom crop and limiting the spread of disease. \*

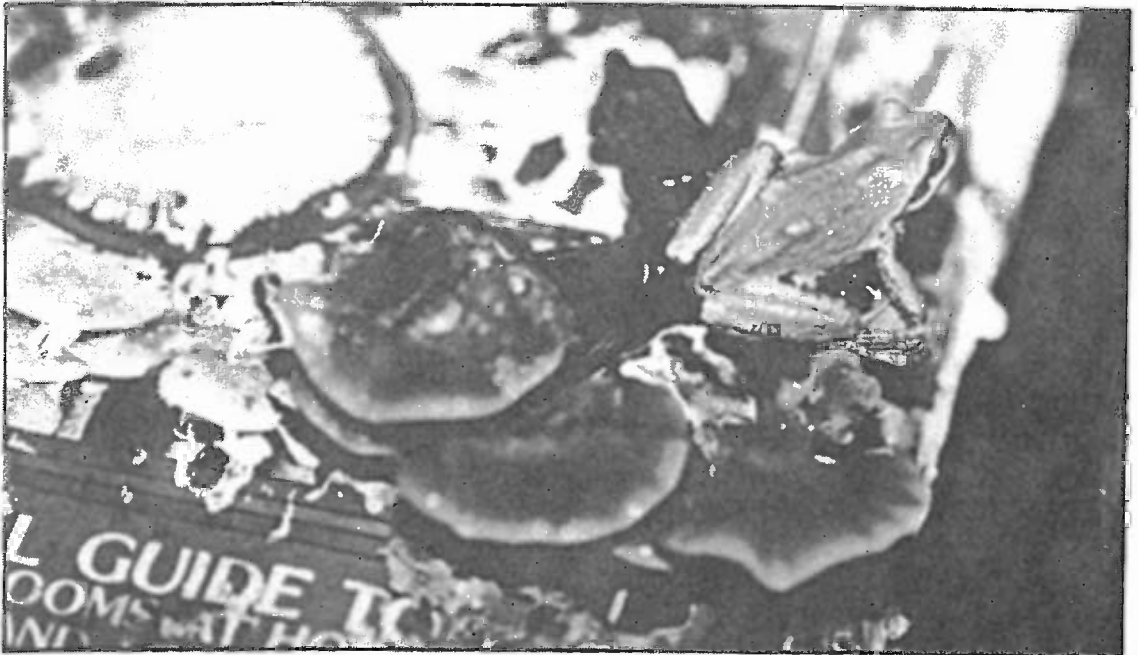

Figure 385. My growing rooms have harbored a resident population of tree frogs for more than 5 years. Each frog consumes dozens of fungus gnats each day. I highly recommend frogs as an effective and natural method for limiting fly infestation. In this case, a frog lies in wait, perched upon Reishi mushrooms fruiting from a copy of *The Mushroom Cultivator*.

\* The historical symbology here, between mushrooms and frogs (or toads), should not go unnoticed.

PROBLEM	CAUSE	SOLUTION
<b>AGAR CULTURE</b>		
<i>Media will not solidify</i>	Not enough agar Insufficiently mixed Bacteria	Add more agar > 20 grams/liter. Agitate before pouring. Increase sterilization time to at least 30 minutes at 15 psi.
<i>Spores will not germinate</i>	Inviabile spores  Improperly formulated media	Obtain fresher spores. Soak in 5 cc. of sterilized . water for 48 hours. Place one drop of spore solution per petri dish. See page 90.
<i>Spores germinate with mold contaminants ("powdery mildews")</i>	Contaminated spores	Isolate & transfer "white spots" from one another to new media dishes. Always move mycelium <i>away</i> from competitors.
<i>Spores germinate with bacterial contaminants ("slime")</i>	Contaminated spores	Use antibiotic media. (1/15 - 1/20 g/liter of gentamycin sulfate). "Sandwich" spores between two layers of anti-biotic media. Isolate mycelium when it appears on top surface.
<i>Mycelium grows then dies back</i>	Poor Media Formulation  Over-sterilized Media  Poor strain	See page 90.  Sterilize for less than 1 hour at 15 psi. Acquire new strain.
<i>Contaminants appear along inside edge of petri dish</i>	Contamination airborne in laboratory	Filter lab air, clean lab. Look for source. Wrap edges of petri dishes with tape or elastic film after pouring & inoculation.

<b>PROBLEM</b>	<b>CAUSE</b>	<b>SOLUTION</b>
<i>Contaminants localized to point of transfer</i>	Culture contaminated	Isolate new culture.
	Scalpel contaminated	Flame sterilize scalpel longer.
<i>Contaminants appear equally over the surface of agar media</i>	Airborne contamination	Filter air & use good sterile technique.
	Contaminated media- Insufficient sterilization	Increase sterilization time.
	Hands upstream of cultures during inoculation in airstream of laminar flow hood	Keep hands downstream of inoculation site.
<i>Media evaporates, cracks, before colonization is complete</i>	Humidity too low	Increase lab rH to 50% or wrap petri dishes with tape or elastic film.
	Culture in airstream	Place cultures outside of airstream.
<b>GRAIN CULTURE</b>		
<i>Grain spawn contaminates before opening, before inoculation</i>	Bacteria endemic to grain	Soak grain overnight to trigger endospores into germination, making them susceptible to heat sterilization.
	Contaminants enter during cool-down	Filter air during cool-down or open pressure vessel at 1 psi in clean room.
<i>Mycelium does not grow</i>	Too dry	Over-sterilized. Cook 1-2 hours at 15 psi. Reduce surface area or porosity of filter media.
	Bacterial contamination	Soak grain spawn overnight. Boil grain in a cauldron before sterilization.

PROBLEM	CAUSE	SOLUTION
	Over-sterilized	Reduce sterilization time.
	Culture not receptive to media formula	Alter media formula.
<i>Mycelium grows but spottily/incompletely</i>	Insufficient distribution of mycelium through grain	Shake jars with greater frequency.
	Insufficient inoculation rate	Increase amount of mycelium placed into each grain jar.
	Bacterial contamination	Clean up strain. Increase sterilization time of grain.
<i>Grain spawn difficult to break-up</i>	Over-incubation	Use spawn sooner.
	Excessive water	Reduce water in formula by 10-20%.
	Use different type of grain	Use rye, wheat or millet Add gypsum. See page 130.
<i>Grain spawn appears pure, but contaminates with mold or bacteria after inoculation.</i>	Mycelium endemically contaminated-co-existing with other organism(s)	Return to stock cultures or clean strain.
	Over-incubation	Use spawn sooner. Normal for old spawn to eventually support other microorganisms
	Underside of filter laden with organic debris, providing a medium for contaminants to grow through.	Soak filter discs in bleach solution in between spawn runs.
	Contamination airborne or from lab personnel.	Install micron filters. Observe good sterile technique.
<i>Jars crack, bags break</i>	Radical fluctuation in temperature and/or pressure	Reduce temperature & pressure flux.
	Inadequate quality	Acquire higher quality, heat tolerant jars & bags.



PROBLEM	CAUSE	SOLUTION
<b>STRAW CULTURE</b>		
<i>Mushrooms fail to form</i>	Improper Initiation Strategy	Consult Chapter 21. Alter moisture, temperature, light, CO <sub>2</sub> , etc.
	Bad strain	Obtain younger strain of known vitality & history.
	Chlorinated or contaminated water	Use activated charcoal water filters to eliminate chemical contaminants.
<i>Mycelium produces aborted mushrooms</i>	Poor Fruitbody Development Strategy	Consult Chapter 21.
	Bad Strain	Obtain younger strain of known vitality & history.
	Mite Contamination	Discard, disinfect and begin anew.
	Nematode Contamination	Minimize contact with soils & increase pasteurization time.
	Insect damage from developing larvae	Shut down growing room, "bleach bomb" for 24 hours, install bug lights and/or frog population, & re-fill with new crop.
<i>Second and third crops fail to produce substantially or at all</i>	Anaerobic contamination in core of substrate mass	Increase aeration or decrease depth of substrate.
	Growing room mis-management	Better management.
	Bad strain	Acquire better strain.
	Insufficient spawning rate	Increase spawning rate.
<i>Green &amp; black molds appearing on straw</i>	Insufficient pasteurization	Increase pasteurization time.
	Prolonged exposure to elevated carbon dioxide levels	Lower CO <sub>2</sub> levels-increase air exchange.

PROBLEM	CAUSE	SOLUTION
	Incubation at too high a temperature	Lower incubation temperature.
<b>SUPPLEMENTED SAWDUST CULTURE</b>		
<i>Mycelium fails to grow through within two weeks</i>	Bags inoculated too hot	Allow to cool before substrate is inoculated
	Insufficient spawning rate	Increase spawning rate.
	Inadequate mixing of spawn through sawdust	Increase mixing and/or spawn rate.
	Mis-match of mycelium & wood type	Use woods native to mushroom.
	Sawdust too dry	Increase moisture.
	Sawdust over-sterilized	Reduce sterilization time.
<i>Mycelium grows &amp; then stops. Often accompanied by foul odors, slimy fluids. Yellow, green, or black molds</i>	Presence of contaminants-bacteria or molds	Consult Chapter 10: The Six Vectors of Contamination.
	Inadequate sterilization	Increase sterilization time
	Sterilization sufficient but contaminated during cool-down	Filter air during cool-down, check autoclave seals, drains, etc.
	Grain or Sawdust spawn infected	Use pure spawn.
	Person inoculating introduced contaminants	Adhere to good sterile technique.
	Bags not separated to allow heat loss during incubation	Space bags 2 in. apart, maintain air temperature at 75° F. (24° C.).
	Airborne contamination	Use HEPA filters & good sterile technique.
	Excessive carbon dioxide levels during incubation (> 25%)	Increase surface area, or transpiration rate of filter media.

PROBLEM	CAUSE	SOLUTION
	One of the above.	Incubate the bacterially contaminated bags at 40-55° F. (4-13° C.) for 1 month. (40-60% are often salvageable.).
<b>PRE-HARVEST PERIOD</b>		
<i>Mycelium grows but fails to produce mushrooms</i>	Monokaryotic strain-absence of clamp connections	Mate with compatible monokaryon—check for clamp connections.
	Bad strain	Acquire new strain.
	Mis-match of strain with substrate formula	Re-devise substrate formula.
	Virus/bacteria/parasitic fungi/nematodes	Regenerate spawn from clean stock cultures.
	Inhibited by environmental toxins	Remove source of toxins.
<b>HARVEST STAGE</b>		
<i>Mushrooms form, but abort</i>	Bad strain	Acquire new strain.
	Poor environmental conditions	Consult Chapter 21 for species.
	Competitors: molds ( <i>Mycogone</i> , <i>Verticillium</i> , <i>Trichoderma</i> ) & bacteria.	Consult Chapter 10: The Six Vectors of Contamination.
		Imbalanced Growing room environment. CO <sub>2</sub> and rH too high. Consult Chapter 21 Species Growth Parameters.
		Mist mushrooms with water containing 1/2 teaspoon of elemental sulphur per gallon. Equivalent to 1 lb. sulphur per 100 gallons of water.
	Chemical contamination, from solvents, gases, chlorine etc.	Remove toxins.

PROBLEM	CAUSE	SOLUTION
<i>Mushrooms form, but stems are long; caps underdeveloped</i>	Inadequate light	Increase or adjust light to correct wavelength.
	Excessive CO <sub>2</sub>	Increase air exchanges.
<i>Massive numbers of mushrooms form; few develop</i>	Poor strain	Obtain better strain.
	“Over-pinning”	Shorten primordia formation period.
	Lack of oxygen, inadequate light	Adjust according to the species’ growth parameters See Chapter 21.
	Inadequate substrate nutrition	Reformulate.
	Dilute spawning rate	Increase spawning rate.
<i>Mushrooms deformed</i>	Competitor organisms ( <i>Mycogone</i> , <i>Verticillium</i> , bacteria, etc.)	Re-balance growing room. environment to favor mushrooms & disfavor competitors.
	Inadequate air circulation	Increase air circulation.
	Excessive humidity or watering	Reduce humidity to prescribed levels. Surface water must evaporate from mushrooms several times per day.
	Bad strain	Acquire better strain.
	Chemical contamination	Remove toxins.
<i>Mushrooms produced on first flush, fail to produce subsequent flushes</i>	Inadequate substrate nutrition	Reformulate.
	Competitors	Consult Chapter 10: The Six Vectors of Contamination.
	Window of opportunity missed	Re-initiate.

<b>PROBLEM</b>	<b>CAUSE</b>	<b>SOLUTION</b>
	Mycelium "panned"	Disturb substrate: break apart & re-pack, allow to recover, and re-initiate.
	Poor growing room management	Improve management.
	Bad Strain	Acquire new strain.
<i>Flies endemic to growing room</i>	Inadequate pasteurization	Extend pasteurization period.
	Open doors, vents, etc.	Improve seals at doors & windows.
	Poor growing room maintenance	Wash down growing room 2-3 times per day. Place 1 cup bleach in drain to kill flies, once per day.
	Slow cycling of crops	Increase crop rotation.
	Inadequate clean-up of growing rooms between "runs"	Remove debris, wash ceilings, walls, & floors using bleach solution. "Bleach bomb" for 24 hours. Bug traps. See Figure 384. Frogs. See Figure 385.
<b>POST-HARVEST</b>		
<i>Mushrooms quick to spoil</i>	Mushrooms too mature when harvested	Harvest when younger.
	Mushrooms too warm before packaging	Chill mushrooms before placing in marketing containers.
	Mushrooms too wet when harvested	Reduce humidity several hours before harvesting.
	Mushrooms improperly packaged	Mushrooms need to breathe. Cellophane or anti-condensate gas permeable wrapping films recommended.
	Mushrooms stored beyond shelf life	Sell mushrooms sooner.



# Descriptions of Environments for A Mushroom Farm

**T**o best understand the individual components making up a mushroom farm, a comparative description of the environments and activities occurring in each room is helpful. Some rooms can accommodate more than one activity, as long as schedules do not conflict. This list is especially useful for designers, architects and engineers who are employed to design a complete facility. Since I do not advocate the use of caustic chemicals, pesticides, and other toxins, these descriptions may not fully address the needs of farms which handle manure-based substrates and subscribe to toxic remedies.

## The Laboratory Complex

Ideally, a specially constructed building or a space within an existing building is retrofitted with the following parameters in mind. Please refer to Appendix II for more information on the necessary equipment and rules of behavior within the laboratory environment.

*Purposes:* To isolate and develop mushroom cultures for generating pure culture spawn.

*Facility:* A building well separated from the growing room complex.

*Maximum Temperature:* 80° F. (26-27° C.)

*Minimum Temperature:* 70° F. (21-22° C.)

*Humidity:* 35-50%

*Light:* 500-1000 lux.

*Insulation:* R16-R32

*Positive Pressurization:* Yes, through HEPA filters.

*Additional Comments:* The laboratory should be uphill from the growing rooms so that passage of spawn is aided by gravity as it is transported. The laboratory is a relatively dry environment, encouraging the growth of mycelium only in protected containers (petri dishes, jars, & bags). Condensation surfaces must be minimized. After construction, every seam should be sealed with silicone caulking.

## The Growing Room Complex

The growing room complex can house all non-laboratory activities within one building. Each room has different requirements according to function. These recommendations should be used as general guidelines, subject to amendment. Growers in humid tropical requirements face a set of problems uniquely different from growers in cold, temperate climates. Ancillary storage & shop maintenance buildings are not listed.

### Environment 1: The Growing Rooms

*Purpose:* To grow as many mushrooms as possible

*Facility:* Rooms vary in size from 10 x 20 ft. to 40 x 100 ft. with 10-20 ft. ceilings and are usu-

ally rectangular in shape with large doors at both ends. Growing rooms should have cement floors, with drains, and equipped with water lines. Electrical boxes and lights must be waterproofed. Internal walls should be constructed of non-degradable materials. Use of wood should be minimized.

*Maximum Temperature:* 80° F. (26-27° C.)

*Minimum Temperature:* 45° F. (7-9° C.)

*Humidity:* 50-100%

*Light:* 50-1000 lux.

*Insulation:* R8-R16 or as needed.

*Positive Pressurization:* Yes, through electrostatic filters.

*Additional Comments:* Ideally, a flow-through design is followed, both in consideration of fresh mushrooms as well as the entry and exit of substrate mass. Removing contaminated substrates into the same corridor through which freshly spawned substrate is being transferred causes cross-contamination. Spent substrate should be exited out of the opposite ends of the growing rooms. Many farms bring their fresh mushrooms into the main hallway, *en route* to the sorting and cold storage rooms.

### Environment 2: The Spawning Room

*Purposes:* A room adjacent to the pasteurization chamber wherein inoculations into bulk substrates are conducted.

*Facility:* The room must be constructed of materials that will not harbor mold colonies and can be washed down with ease. The height should be sufficient to accommodate the unloading of the steam box, conveyors (if used), elevated platforms and funnels for filling columns (12-16 ft.). Cement floors and moisture



proof electrical fixtures are essential for safety.

*Maximum Temperature:* 90° F. (32-33° C.)

*Minimum Temperature:* Ambient.

*Humidity:* Fluctuating from ambient to 100%.

*Light:* 200-500 lux. Needed only for ease of personnel. Skylights or moisture-proof fluorescents suffice.

*Insulation:* None needed.

*Positive Pressurization:* Yes, through HEPA filters

*Additional Comments:* Once this room is thoroughly washed down with a dilute bleach solution prior to spawning, the fan/filter system is activated for positive pressurization. The filtration system is ideally located overhead. Air is passively or actively exhausted near to the floor. During inoculation, this room becomes very messy, with spawn and substrate debris accumulating on the floor. Since the spawning room is only used directly after each run through the pasteurization chamber, it can serve more than one purpose during non-spawning days. The spawning room should be adjacent to the main corridor leading to the growing rooms to facilitate substrate handling.

### **Environment 3: The Pasteurization Chamber or Phase II Room**

*Purposes:* To pasteurize bulk materials (straw, bagasse, etc.) by subjecting the substrate to steam for a prolonged period of time (2-24 hours).

*Facility:* Usually rectangular, the pasteurization chamber is a highly insulated room with a false floor, usually screened or grated, under which steam is injected. Two drains are recommended

per pasteurization box. The drains should have a screened basket over them to prevent clogging. Ideally the drain line should have a check or gate valve to prevent contaminants being drawn into the pasteurization box during cool-down. The walls and floors must be constructed in such a manner to withstand radically fluctuating temperatures and humidities. Rooms are often constructed of cinder-block, cement formed, or temperature tolerant fiberglass reinforced plastic (FRP). Wood construction is strongly discouraged. The pasteurization chamber should have ample head-space. Large farms use "walking floors" or a net pulled by a winch, facilitating off-loading. (See Figure 148.)

*Maximum Temperature:* 210° F. (99-100° C.)

*Minimum Temperature:* Ambient.

*Humidity:* 10-100% rH

*Light:* Minimal or none.

*Insulation:* r30+

*Positive Pressurization:* Yes, through HEPA filters.

*Additional Comments:* Pasteurization tunnels take lot of abuse from the loading and unloading of substrate. The screened floors should be removable so waste debris can be gathered after each run. Once emptied the rooms should be doused with a bleach solution to limit the growth of any mold colonies. I have seen pasteurization tunnels made from reconverted old saunas, silage vessels, grain silos, semi-trucks, ocean cargo containers, beer fermentation vats, etc... Any doors or openings must be tightly gasketed. Provisions for the ease of filling and unloading aids production efficiency.

## Environment 4: The Main Corridor: A Highway for Substrate & Product Flow

*Purposes:* A central hallway connecting the essential environments to one another, facilitating movement of materials, products and personnel.

*Facility:* Often times, a metal framed, open truss building, is centrally located, broadside to the growing rooms. Ceilings should be at least 12 ft., ideally 20 ft. high. Here again, wood surfaces should be minimized. Floors should be cement with drains and have access to water lines for maintenance and clean-up.

*Maximum Temperature:* Ambient

*Minimum Temperature:* Ambient

*Humidity: Ambient:* 20-80% rH

*Light:* Skylights or moisture proof fluorescents

*Insulation:* None needed.

*Positive Pressurization:* Not needed.

*Additional Comments:* Since this is a high traffic area, two-way passing is essential. Those using forklifts must have ample turn-around space for maximum mobility. Many cultivators have charts and/or remote temperature sensors constructed into the walls by each growing room. Bug-traps are placed at several locations to intercept winged intruders before possible entry into the mushroom growing rooms.

## Environment 5: Sorting, Grading & Packing Room

*Purpose:* To sort, grade, and package mush-

rooms into their end-user containers.

*Facility:* A well lighted room with gravity conveyors, sorting tables, and often a blast-chiller which quickly cools the mushrooms prior to packaging and storage in the refrigeration room. This room is usually located at the end of the main corridor and is immediately adjacent to the refrigeration and shipping rooms.

*Maximum Temperature:* 50° F. (10° C.)

*Minimum Temperature:* 35° F. (1-2° C.)

*Humidity:* 50-75% rH

*Light:* 500-1000 lux.

*Insulation:* R30

*Positive Pressurization:* No

*Additional Comments:* I have seen a number of configurations of this type of processing room. Mushrooms usually arrive in open-grate plastic carrier baskets. The baskets are placed into the airstream from the blast chiller (or in the cold room) awaiting sorting into cardboard, end-user boxes. Although this room is kept cool, the packaging personnel are comfortable at this temperature, busily, sorting, weighing, labelling, and arranging boxes for distribution.

## Environment 6: The Refrigeration Room

*Purposes:* To chill mushrooms to 35° F. (1-2° C.) so they can be maximally preserved.

*Facility:* A standard refrigeration room.

*Maximum Temperature:* 38° F. (3° C.)

*Minimum Temperature:* 32° F. (0° C.)

*Humidity:* 60-80% rH.

*Light:* Only as needed for personnel.

*Insulation:* R30-R60.

*Positive Pressurization:* No.

*Additional Comments:* Installers should engi-

near systems with mushroom preservation in mind, paying particular attention to humidity concerns. Standard refrigeration systems usually suffice, except that humidity must be kept between 60-85% rH to prevent sudden dehydration of the product. Humidity in excess of 90% often causes mushrooms to "re-vegetate", causing a grayish fuzz, and accelerating spoilage. By 1995, freon will be banned as a refrigerant and non-ozone destroying substitutes will be used. New refrigeration systems, including non-mechanical, carbon dioxide based designs, are being developed. I have no information concerning their applicability to chilling and preserving mushrooms. Sufficient air-flow is essential to effect slow evaporation off the cap surfaces. Still-air refrigeration systems cause mushrooms to quickly rot unless the evaporation rate is increased to compensate.

### **Environment 7: Shipping & Receiving Room**

*Purpose:* To transfer mushrooms from the cold storage to the shipping/receiving area. Many farms have loading docks at the same elevation as the beds of the produce trucks picking up and delivering the product. Most facilities are equipped with overhanging doors.

*Facility:* An open, high ceiling room with direct access to the main corridor, the sorting room, and/or the refrigeration room.

*Maximum Temperature:* Ambient

*Minimum Temperature:* Ambient

*Humidity:* Ambient

*Light:* As needed for personnel. Fluorescents do not need lenses.

*Insulation:* Minimal

*Positive Pressurization:* None

*Additional Comments:* A high traffic area, the shipping & receiving room, besides its obvious purposes, is also used as a buffer, limiting the impact of environmental fluctuations from the outside. Mushrooms are usually weighed and then 10% is added to offset weight loss due to evaporation during shipment.

### **Environment 8: Production/Recapture Open-Air Growing Room**

*Purposes:* To recapture as many mushrooms possible which can not be realized in controlled environment growing rooms. This building can solve a dilemma constantly confronting the growing room personnel: to maximize mushroom yield while not jeopardizing future crops as contaminants become more common as the cycle comes to completion.

By the third or fourth flush, yields are in a state of precipitous decline. Rather than discarding this mycelium, additional harvests can be realized, with minimum effort, if the substrate is placed outside during conducive weather conditions. In the temperate regions of the world, these favorable weather conditions span several months. During these moist months, Oyster and Shiitake mushrooms produce prolifically outdoors. I am continually amazed at the size of mushrooms that can be harvested outside from "spent" straw or sawdust that has been exported from the indoor growing rooms. Two types of buildings serve this purpose well.

*Facilities:* Either a hoop frame structure covered with "bug-out" or shade cloth or a covered building with walls constructed of the same, draping from the outer roof joists.

*Maximum Temperature:* Ambient

*Minimum Temperature:* Ambient

*Humidity:* Ambient, augmented to 85-100% by overhead sprinklers.

*Light:* Ambient. Indirect natural light coming from the sides is best.

*Insulation:* None needed.

*Positive Pressurization:* n/a

*Additional Comments:* Two structures meet these needs well. The first is the simplest. By constructing a hoop type greenhouse and covering it with 70-80% shade or "bug-out" cloth, moisture can penetrate through to interior and

air flow is naturally high. If the pore spacing is fine enough, as in the commercially available anti-bug screens ("bug-out"), then flies will be hindered from entry. If a metal roofed, open sided, hay-barn is used, then draping the this fabric from the outer frame to create fabric walls will accomplish a similar function. In either environment, a simple, overhead misting system activated by a timer or hand controls, will promote additional mushroom crops. Compared to the details needed for the controlled environment, high efficiency growing rooms, the construction of these types of rooms are self-explanatory and open to modification.

## Designing and Building A Spawn Laboratory

**M**ushroom cultivation is affected as much by psychological attitude as it is by scientific method. The synergistic relationship between the cultivator and his cultures becomes the overwhelming governing factor in determining laboratory integrity. Since contamination is often not evident for days, even weeks, after the mistake in technique has occurred, the cultivator must develop a super-sensitive, prescient awareness. Practically speaking, this means that every time I enter the laboratory, I do so with a precautionary state of mind.

The laboratory is designed and built for the benefit of the mushroom mycelium. The role of the cultivator is to launch the mycelium onto appropriate sterile substrates in the laboratory and then leave. The less non-essential time spent by humans in the laboratory, the better, since humans are often the greatest threat to the viability of the mushroom cultures. Growing mushrooms successfully is not just a random sequence of events scattered throughout the week. One's path through the facilities, growing rooms and laboratory, can have

profound implications on the integrity of the entire operation.

The growing of mushroom mycelium in absence of competitors is in total contradiction to nature. In other words, the laboratory is an artificial environment, one designed to forestall the tide of contaminants seeking to colonize the same nutritious media that has been set out for the mushroom mycelium. This was a frightening state of affairs for most would-be cultivators until books like *The Mushroom Cultivator* by Stamets & Chilton (1983) and this one offered simple techniques for making sterile culture practical for mushroom cultivators. These volumes represent, historically, a critical step in the passing of the power of sterile tissue culture to the masses at large.

Before the advent of HEPA filters\*, sterile culture work succeeded only by constantly battling legions of contaminants with toxic disinfectants, presenting real health hazards to the laboratory personnel. Now, the use of disinfectants is minimized because the air is constantly being re-filtered and cleaned. Once airborne contamination is eliminated, the other vectors of contamination become much easier to control. (Please consult Chapter 10 for the Six Vectors of Contamination.)

Most people reading this book will retrofit a bedroom or walk-in pantry in their home. Large scale, commercial operations will require a separate building. In either case, this chapter will describe the parameters necessary for designing and building a laboratory. If you are building a laboratory and pay strict attention to the concepts outlined herein, contamination will be

minimized. Like a musical instrument, the laboratory must be fine tuned for best results. Once the lab is up and running, a sterile state of equilibrium will preside for a short time. Without proper maintenance, the lab, as we say "crashes". The laboratory personnel must constantly clean and stay clean while they work. Since the laboratory personnel are the greatest threat to the lab's sterility, they must shoulder the responsibility for every failure.

The laboratory should be far removed from the growing rooms, preferably in a separate building. The air of the laboratory is always kept free of airborne particulates while the growing rooms' air becomes saturated with mushroom spores. *The growing rooms are destined to contaminate.* Even the spores of mushrooms should be viewed as potential contaminants threatening the laboratory. If both the laboratory and growing rooms are housed in the same building, contamination is much more likely. Since the activities within the laboratory and growing rooms are distinctly different, separate buildings are preferred. I know of several large mushroom farms which built their spawn laboratory in amidst their growing rooms. Their ability to generate pure culture spawn is constantly being jeopardized by the contaminants coming from the growing rooms. Every day, the laboratory manager faces a nightmarish barrage of contaminants.

A good flow pattern of raw materials through the laboratory, and of mature cultures out of the laboratory is essential. Farms with bad flow patterns must constantly wage war against seas of contaminants. The concepts are obvious. The positioning of the growing room exhaust fans should be oriented so as not to direct a "spore stream of contaminants" into the laboratory filtration system. Furthermore, the design of a mushroom farm's buildings should

\* HEPA = High Efficiency Particulate Air Filters eliminate particulates down to .3 microns with an efficiency rating of 99.99%. ULPA (Ultra-Particulate Air) filters screen out particles down to .1  $\mu$  m with 99.9999% efficiency.

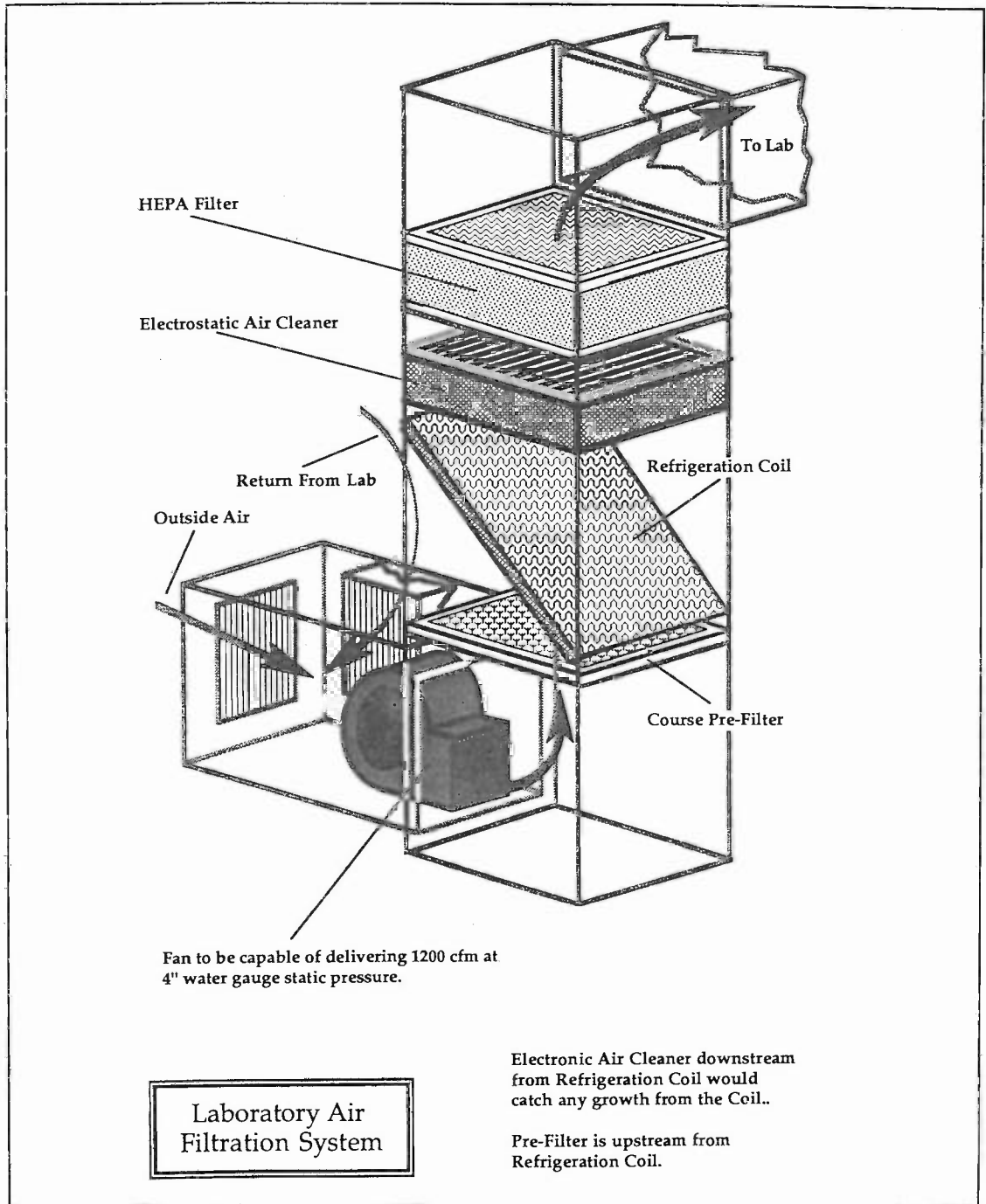

Figure 386. Exteriously located, air filtration system for the laboratory. This configuration allows the filtration, heating and cooling of incoming and recirculated air. The filters must be removed periodically for cleaning and/or replacement.

take into account prevailing wind direction, sunlight exposure, shade, the positioning of the wetting or compost slabs, the location of the bulk substrate storage, and the overall flow patterns of raw materials and finished goods.

The major problem with having a laboratory within a home is the kitchen—a primary breeding ground for contamination. Rotting fruits, food spoiling in the refrigerator, and garbage containers represent a triple-barrelled threat to the laboratory's integrity with the air and the cultivator as carrier vectors. However, good sterile technique coupled with the use of HEPA filters, can make a home laboratory quite functional for the small and mid-size cultivator. Most importantly, the cultivator must have a heightened awareness of his/her path through the sources of contamination before attempting sterile tissue culture. I prefer to do my laboratory work in the mornings after showering and putting on newly washed clothes. Once the lab work is completed, the packaging and growing rooms can be entered by the laboratory personnel. Otherwise, these areas should be strictly off-limits. In a mushroom facility, duties must be clearly allocated to each person. If you are working alone, extra attention to detail is critical to prevent cross-contamination.

## Design Criteria for A Spawn Laboratory

The design criteria for constructing a spawn laboratory is not complicated. A short description of my lab might help the reader understand why it works so well. My laboratory is housed in a 1440 sq. ft. building. A 15 HP boiler is located in its own room and generates steam for the 54 in. diameter, 10 ft. long, double door retort. The walls and ceilings are covered with FRP (Fiber Reinforced Plastic). The lights are

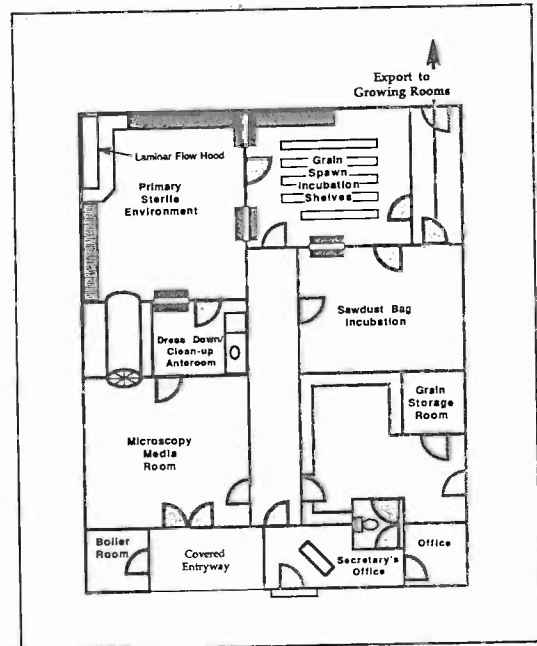

Figure 387. Floor plan of a mushroom spawn laboratory. Most of the substrate enters the clean room through the autoclave (mid-way left). Spawn is exported from laboratory to the growing rooms. Spawn is rotated frequently out of the laboratory.

covered with waterproof, dust-proof lenses. Plug-ins for the remote vacuum system are handy and well used. To enter, you must pass through three doors before reaching the clean room. In the clean room, a 2 ft. high by 12 ft. long home-made laminar flow bench gives me ample freedom of hand movement and surface area. (See Figure 72.) Fresh, outside air is serially filtered and positive-pressurizes the lab from overhead through a coarse pre-filter, an electrostatic, and finally a 24 x 24 HEPA filter. A return duct, recycling the room's air should be on the floor but, I admit, is not. By locating the return duct low in the laboratory, contaminants are constantly being pushed to and skimmed off the floor. My laminar flow bench—with its massive surface area—recir-



culates the entire room once every 1.3 minutes. This is far more than what is minimally necessary.

Here are a few key concepts in designing laboratory, whether the clean room is in the home or in its own building. If incorporated into the design of your facility, contamination vectors will be minimized. Following this list are helpful suggestions of behavior which, in combination, will give rise to an efficient, steady state clean room.

**1) Positive Pressurize Laboratory.** The laboratory should be continuously positive-pressurized with fresh air. The fresh, outside air is serially filtered, first through a coarse pre-filter (30% efficient at  $1u$ ), then an electrostatic filter (95–99% efficient at  $1u$ ), and finally a HEPA filter (99.99% efficient at  $.3u$ ). Blowers must be properly sized to overcome the cumulative static pressures of all the filters. In most cases, the combined static pressure approaches 1.25 inches. (1 inch of static pressure is the measure of resistance represented by the movement of water 1 inch, in a 1 inch diameter pipe.) Air velocity off the face of the final filter should be at least 200 feet per minute. For a 400 sq. ft. clean room, 2 ft. x 2 ft. x 6 in. filters should be employed. The construction of the intake air system should allow easy access to the filters so they can be periodically removed, cleaned, and replaced if necessary. (See Figure 386.) Fresh air exchange is essential to displace the carbon dioxide and other gases being generated by the mushroom mycelium during incubation. Should carbon dioxide levels escalate, the growth of contaminants becomes more likely. Sensitive cultivators can determine the quality of the laboratory immediately upon entering using their sense of smell.

**2) Stand-alone laminar flow bench.** A laminar flow bench constantly recirculates

the air within the laboratory. The air entering the laboratory has been already filtered from the positive pressurization system described in the previous paragraphs. By having two independent systems, the lifespan of the filter in the laminar flow bench is greatly extended. And, the clean room becomes easy to maintain. Furthermore, I am a strong believer in creating a laboratory that is characterized by turbulent air streams, with a high rate of impact through micron filters. Turbulent, filtered air in the laboratory is far more desirable than a still air environment. The key idea: *if airborne particles are introduced, they are kept airborne from turbulence. If kept airborne, particles are soon impacted into the micron filters.* This reduces the stratification of contaminant populations in the laboratory, and of course, temperature variations. It is important to note that this concept is diametrically opposite to the “old school” concept that still-air in the laboratory is the ideal environment for handling pure cultures.

**3) Double to triple door entries.** There should be at least two doors, preferably three doors, separating the clean room from the outside environment. Double door entries are a standard in the industry. Doors with windows have obvious advantages in preventing accidents. Furthermore, the doors should be gasketed with dirt skirts. When the doors swing outwards as you exit the innermost clean room, the export of mature spawn or blocks is made easier. (I prefer to kick the doors open upon exiting as often times my hands are full.) As workers travel towards the clean room, they enter rooms hygienically cleaner than the previous, and into increasingly, higher pressure zones. Floor decontamination pads, otherwise known as “sticky mats” are usually placed before each

doorway to remove debris from the feet.

With ultra-modern clean rooms, a double door anteroom, called a "Decontamination Chamber", utilizes the down-flow of HEPA filtered air over the worker who stands on a metal grate. The air is pushed from above and actively exhausted through the floor grate to the outside. The principle concept here is valid: *the constant descension of airborne particulates improves laboratory integrity.* Another variation of this concept is the replacement of the solid inner doors with down-flowing air curtains. However, decontamination chambers and air curtains should be the last projects on a long list of other priorities for the financially conservative investor.

#### 4) Interior surfaces not biodegradable.

Interior surfaces such as the walls, counter-tops, shelving, etc. should not be able to support mold growth. Wood and sheet rock should be avoided. The floors should be painted several times or overlaid with a chemically resistant, cleanable mat. When using a paint, use a non-mildewing enamel. (*Caution:* Do not use paint containing fungicides, particular any containing tributyl tin oxide, an extremely dangerous toxin to both humans and mushrooms.) Counter-tops can be made of stainless steel or a hardened laboratory grade formica. The shelves storing the incubating bags should be wire meshed, and not solid, so that the heat generated from incubation is dissipated. Petri dish cultures can be stored on solid shelves.

5) **Walls and ceiling well insulated.** Ambience of temperature is critical for maintaining a laboratory. Temperature fluctuation causes two problems. When temperatures within the lab radically change from day to night, condensation forms within the spawn containers and on

the upper, inside of the petri dishes. These water droplets will carry otherwise-dormant contaminants down to the rich media. Bacteria particularly love condensation surfaces. When a laboratory is run at 50% relative humidity and 75° F. (24° C.) condensation should dissipate within 24 hours after autoclaving. The other problem caused by temperature fluctuation is that the outer walls of the laboratory, especially those made of concrete, sweat. I had one small home laboratory that grew an enormous colony of white mold on a painted, white cinder block wall. The whole laboratory contaminated despite my best efforts. Only when I washed the wall did I find the source. If your only option is a laboratory with an outside facing cinder block wall, make sure the pores have been sealed with a thick coat of paint and permanently place an electric, baseboard heating unit facing the wall to eliminate the possibility of condensation.

#### 6) Lights covered with dust-proof covers.

Fluorescent lights should be covered with lens coverings. Uncovered lights ionize particulates which will collect as dust layers on oppositely charged surfaces. Over time, a habitat for contaminants builds. Ionizers are similar in their effect and are greatly over-rated. (See Consumer Reports, Oct. 1992.)

7) **Remote vacuum cleaning system.** Since constant cleaning must occur throughout the inoculation process, having the ability to quickly pick up spilled grain and sawdust greatly enhances the ease of inoculation. When inoculations are done quickly, the likelihood of airborne fall-out (primarily from the cultivator) is minimized. Brooms should *never* be used in the laboratory. Wet/dry remote vacuums run the risk of clogging and then breeding contaminants. Therefore, a "dry" remote vacuum system is recommended.

## Good Clean Room Habits: Helpful Suggestions for Minimizing Contamination in the Laboratory

1) **No shoes in the laboratory** The lab is strictly a “shoes-off” environment. Disposable booties are often used over socks. No outer clothing that has been exposed to the outside air should be worn into the laboratory.

2) **Wear newly laundered clothes and/or a laboratory coat**. Once your clothes have come into contact with contaminants, these contaminants will become airborne within the laboratory. Two primary sources of contamination are people’s pets and their car seats. Once the laboratory personnel come in contact with contamination sources, their usefulness in the laboratory has been jeopardized.

3) **Wash hands frequently with antibacterial soap and isopropanol**. Personnel should thoroughly wash their hands before entering the laboratory and, with frequency, every 1/2 hour during the course of inoculations. Isopropanol (“rubbing”) alcohol is used for wiping countertops, hands, and topically sterilizing tools. Other disinfectants are available from the hospital supply industry.

4) **Frequently mop floors with a 10% bleach solution**. The lab floors should be mopped at least once a week, and directly after each major run. Two buckets are used: one for bleach and one for rinsing the dirt-laden mop. Mop heads should be frequently replaced.

5) **Do not conduct inoculations when you are sick with a cold, the flu, or other contagious illnesses**. I know of cases where cultivators have inadvertently cultivated *Staphylococcus* bacteria and re-infected themselves and others. Face masks should be worn

if you have no option but to work when you are sick.

6) **Do not speak, exhale, or sing while conducting inoculations**. Your breath is laden with bacteria that thrive in the same media designed for the mushroom mycelium. If you have a telephone in your laboratory, be aware that it often becomes a redistribution point for contamination.

7) **Remove trash and contaminated cultures daily**. I do not have wastebaskets in my laboratory, forcing me to remove trash constantly and preventing a site for contamination.

8) **If cloning a specimen, never bring sporulating mushrooms into the laboratory**. Ideally, have a second, small, portable laminar flow hood specifically used for cloning. I use this same laminar flow hood as a “Micron Maid” to help keep airborne particulates at reduced levels in downstream environments. New petri dish cultures from clones should be wrapped with elastic film or tape to prevent the escape of molds, bacteria, and mites into the laboratory. If sporulating molds are visible, isolate in a still-air environment.

9) **Isolate cultures by placing petri dishes on “sticky mats”**. I came up with this innovation when fighting mites and trying to prevent cross-contamination. Sticky mats are also known as Decontamination Floor Pads. See Figure 60.

10) **Establish a daily and weekly regimen of activity**. Daily and weekly calendar schedules for managing the laboratory will help give continuity to the production stream. Since so many variables affect the outcome of mushroom cultivation, try to establish as many constants as possible.

11) **Rotate spawn frequently**. Do not let cultures and spawn over-incubate. Over-incubated Oyster cultures are especially a hazard to the

lab's integrity. After 3-4 weeks, Oyster mushrooms will fruit within their containers, often forcing a path through the closures. If unnoticed, mushrooms will sporulate directly in the laboratory, threatening all the other cultures.

The laboratory's health can be measured by the collective vitality of hundreds of cultures, the lack of diseases, and the diversity of strains. Once filled to capacity with the mycelia of various species, the lab can be viewed as one thermodynamically active, biological engine. The cultivator orchestrates the development of all these individuals, striving to synchronize development, *en masse*, to meet the needs of the growing rooms.

Success in mushroom cultivation is tantamount to not cultivating contaminants. Confounding success is that you, the caretaker cultivator, are resplendent with legions of microflora. Individuals vary substantially in their microbial fall-out. Smokers, pet owners, and even some persons are endemically more contaminated than others. Once contamination is released into the laboratory, spores soon find suitable niches, from which a hundred-fold more contaminants will spring forth at the earliest opportunity. As this cycle starts, all means must be enacted to prevent outright mayhem. Contamination outbreaks resemble dominos falling, and is soon overwhelming to all but the most prepared. The only recourse is the mandatory shutting down of the entire laboratory—the removal of all incubating cultures, and the necessary return to stock cultures. After purging the lab of virtually everything, a strong solution of bleach is used for repetitive cleaning in short sequence. Three days in row of repetitive cleaning is usually sufficient. Clearly, prevention is a far better

policy than dealing with contaminants after the fact.

No matter how well the laboratory is designed, the cultivator and his/her helpers ultimately hold the key to success or failure. Each individual can differ substantially in their potential threat to a clean room. Here's a poignant example. At one time when contamination was on an upward spiral, I had eliminated all the vectors of contamination except one: the MCU's, mobile contamination units—which includes people and other mobile organisms. Determined to track down the source, I brought in an expensive airborne particulate meter, used commonly by the computer industry to judge the quality of clean rooms. This unit measured airborne contamination per cubic meter through a range of particle sizes, from .10 microns to >10 microns.

Several fascinating results were observed. One obvious measurement was that, in a calm air room, 100 times more particulates were within one foot of the floor than were within a foot of the ceiling. *Truly, the air is an invisible sea of contaminants.* What was most surprising was the contamination fall-out from each employee. Standing each employee in the airstream coming from the laminar flow bench, I recorded downwind particle counts. The contamination source was immediately identified: an employee was generating nearly 20 times the contamination fall-out than anyone else. The dirty employee was summarily banned from the laboratory. Soon thereafter, the integrity of the laboratory was restored... The lesson learned— that humans carry their own universe of contaminants—and are the greatest threat to clean room integrity.

---

# The Growing Room: An Environment for Mushroom Formation & Development

**T**he first attempts at growing mushrooms indoors were in caves in France late in the 18th century. They provided an ideal environment for the Button Mushroom (probably *Agaricus brunnescens*): constant, cool temperature and high humidity. To this day, cave culture for the button mushroom is still widely practiced. One of the largest mushroom farms in the world utilizes an extensive network of caves in Butler County, Pennsylvania. Cave culture has one major drawback for gourmet mushroom production: darkness.

The Button mushroom does not require, nor is it sensitive to light. In contrast, all the mushrooms described in this book are phototropic. This major difference—the need for light—presents a financial obstacle to the retrofitting of Button mushroom farms into gourmet mushroom production facilities. Many gourmet mushroom farms must build customized growing rooms. But, in many cases, other types of structures can be retrofitted for commercial production. Here are some examples:

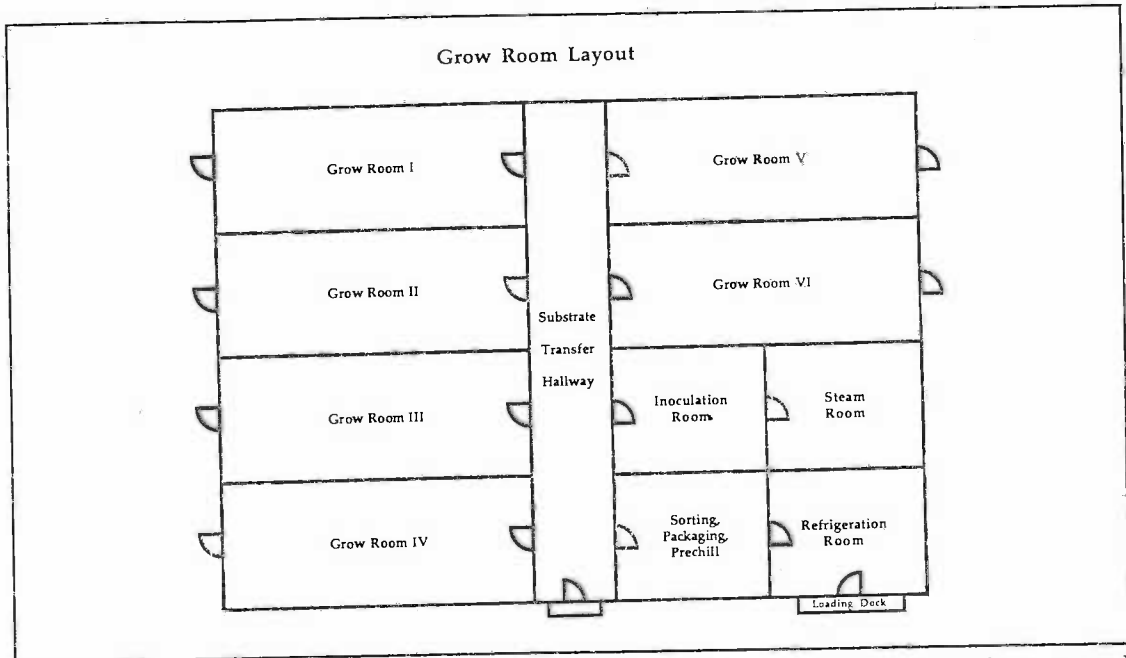

Figure 388. Floor plan of standard growing room complex. This configuration allows for 6 growing rooms and processing areas to be housed under one roof.

airplane hangers  
 army barracks  
 basements  
 cargo containers  
 caves  
 greenhouses  
 mines  
 potato bunkers  
 Quonset huts  
 slaughter houses  
 train & highway tunnels  
 volcano (lava) tubes

airplane shells  
 barns  
 bomb shelters  
 car washes  
 dairies  
 hog farms  
 missile silos  
 poultry sheds  
 ship hulls  
 train cars  
 warehouses

In general, custom designed growing rooms will perform better than structures which have been engineered for other purposes. However, with wise modifications, any of the above structures can be made into intensive growing chambers.

Whereas the laboratory is maintained at a constant temperature and humidity, the grow-

ing room's environment is fluctuated during the development of the mushroom crop. These changes in environment are specific, and sometimes must be radical, to trigger the switch-over to mushroom formation and development. A whole new set of skills is demanded of the growing room manager which are distinctly not needed by the laboratory technician. The ability of the manager to implement these changes is directly affected by the design of the growing rooms. Here are some of the design criteria that must be satisfied for creating a functioning growing room.

## Design Criteria for the Growing Rooms

1) **Shape** The general shape of a growing room should be rectangular. I have never seen a square or circular growing room function well. The growing room should be at least twice as

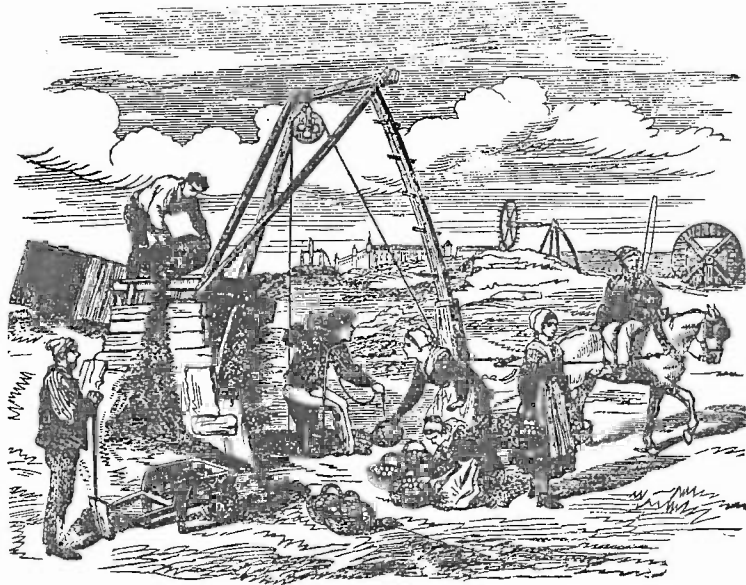

MOUTH OF MUSHROOM-CAVE NEAR PARIS

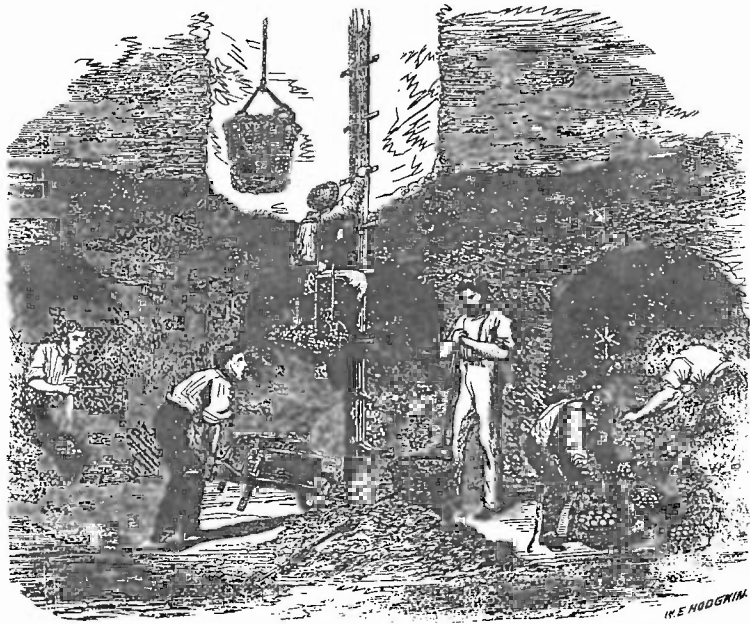

BOTTOM OF SHAFT OF MUSHROOM-CAVE

Figure 389. Caves were first used as growing chambers in France circa 1868. (Reprinted from Robinson's Mushroom Culture (1885)). See also Figure 12.

long as it is wide. This configuration allows for air to be distributed down a central duct-work. The rectangular shape is naturally process-oriented: permitting the flow-through of substrate materials and fresh mushrooms. Rectangular rooms are simply easier to manage.

**2) Interior walls** The inside skin of a growing room must be built of water/mold resistant materials. Fiberglass, polycarbonate, acrylic, glass, galvanized metals can all be used for interiorizing a growing room. The material of choice, by most professional cultivators, is called FRP for Fiberglass Reinforced Plastic. This high temperature extruded fiberglass material has a smoothed finish, and its pliability makes installation simple. Furthermore, FRP will not be degraded by mold fungi, does not out-gas toxic fumes, and is tolerant to most cleaning agents. Wood or metal surfaces can be painted with a mold/rust resistant glazing. Hammerite™, Exterior Varathane™, or marine base enamel paints have been used in the past with moderate success. Cultivators should check with local ordinances so that the materials used in their growing rooms fully comply with food production and building code standards.

For those with limited budgets, the cheapest material is polyethylene plastic sheeting used by the greenhouse industry. This material usually survives no more than two or three years under the conditions used for growing mushrooms. I have attached greenhouse sheeting using galvanized staples over lengths of thick plastic tape.

**3) Doors** As with the laboratory, the growing rooms should be protected from the outside by at least two doors. The first door from the outside leads into an operations room or hallway where the second door opens into the growing room. Doors should

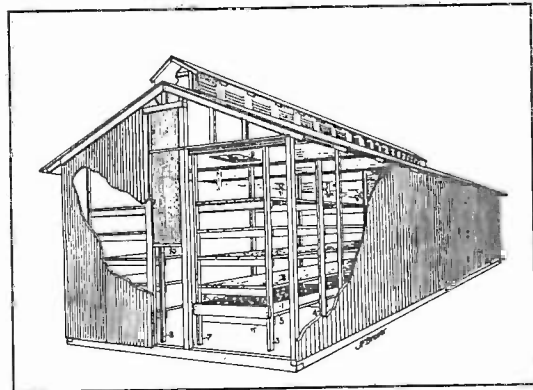

Figure 390. The first growing rooms resembled chicken houses. Reprinted from a 1929 USDA circular: The Mushroom Growing House.

be at least 4 ft. x 8 ft. Some farms have two 5 ft. x 10 ft. double-opening bay doors, or a 10 ft. x 10 ft. sliding door. These large doors allow the easy filling and emptying of the growing rooms. A small door is sometimes inner framed within one of the larger doors so the growing room environment is not jeopardized when only personnel need to enter. In any event, the doors should accommodate small forklifts or similar machinery which need access to the growing rooms. The doors should be made of a material that does not support the growth of molds. The bottom of the door is often fitted with a brush-skirt that discourages insects from entering. The door jams are usually gasketed to assure a tight seal when closed.

At the opposite end of the growing room, a similarly sized exit door should be installed. This door facilitates the emptying of the growing room after the cropping cycle has been completed. To bring aged substrate, which is often contaminated after the 4th or 5th flush, into the same corridor that leads to other growing rooms presents a significant cross-contamination vector.



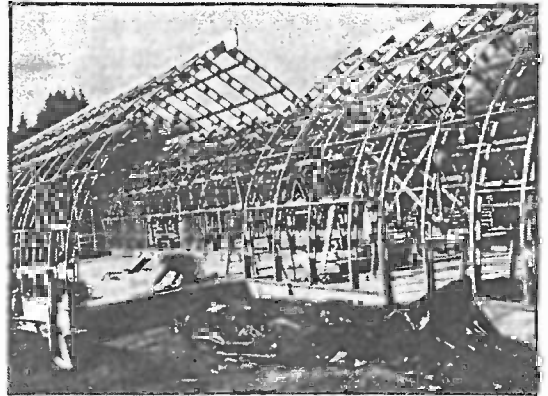
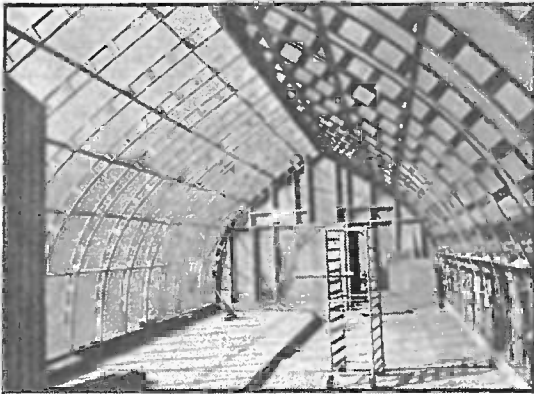

Figure 391 & 392. Modified gothic framed buildings have several advantages. Simple and quick to build, the inside curvature of the walls eliminates condensation from dripping onto the crop. The condensation adheres to the walls and streams to the floor where it is re-evaporated or drained off. The peak roof allows for the removal of excess heat and/or the mixing of humidity and air prior to contact with the mushroom crop.

Many farms employ pass-through curtains, usually made of clear, thick, over-lapping strips of plastic. These are especially useful in the sorting, packaging, and refrigeration rooms. However, pass-through curtains do not

afford a tight enough seal for protection of the growing rooms from other environments.

4) **Structures insulated** Environmental control systems will function far better in growing rooms that are insulated than in those

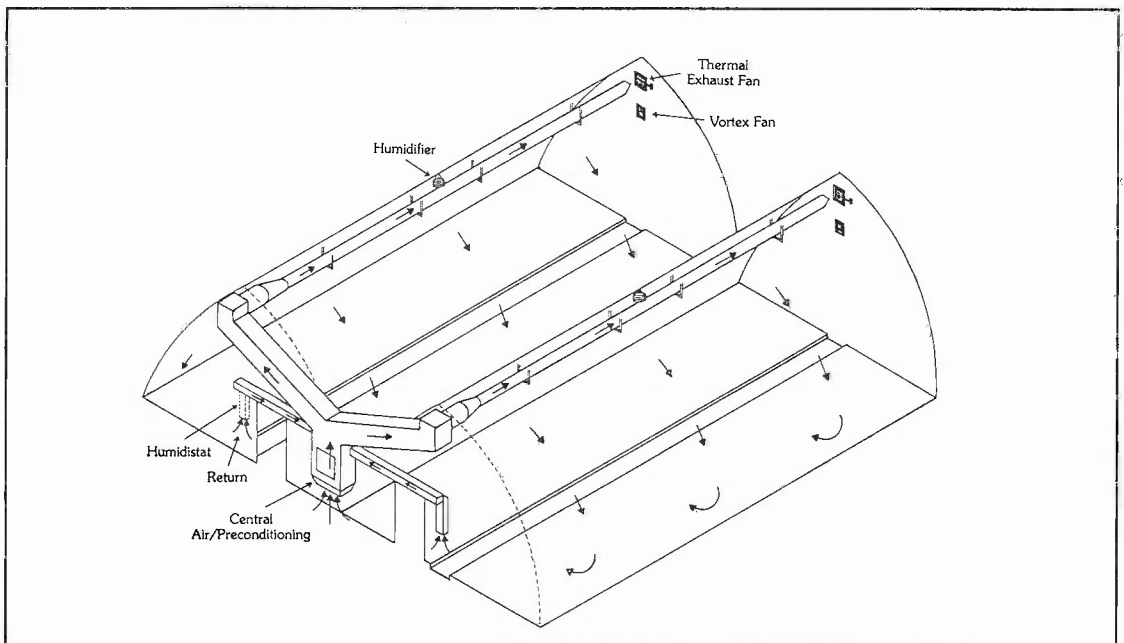

Figure 393. Two modified gothic-shaped greenhouses supplied by central air system.

that are not. Some strains of mushrooms are far more sensitive to temperature fluctuation than others. In localities where temperature fluctuation is extreme, insulation is essential. Some cultivators partially earth-berm portions of their growing rooms for this purpose. When using insulation, make sure it is water-repellent and will not become a food source for molds.

**5) Inside roof** The inside roof should be curved or peaked for heat redistribution by the air circulation system. Furthermore, the slope of the inside roof should be angled so that condensation adheres to the sloped roof surface and is carried to the walls, and eventually spilling onto the floor. This allows for the re-evaporation from the floor back into air. The height of a growing room should be at least 10 feet, preferably 12-16. At least 4 to 6 feet of free air space should be above the uppermost plateau of mushrooms.

Flat roofs encourage condensation, and a microclimate for contamination growth. If the cultivator has no choice but to work with a flat roof, I recommend the installment of lengths of 6-12 inch diameter drain-field pipe, perforated every 2 feet with 1 inch holes, down the length of each growing room at the junction of the wall and the ceiling. By installing a "T" mid-span, and locating a downward flowing duct fan at the base of the "T", air will be drawn into the holes. This scheme will eliminate the dead-air pockets which form along the corner of the wall and ceiling. After fine tuning, entrainment of the air can be greatly improved. (Entrainment can be measured by a "smoke or steam" test and observing the swirling air patterns.)

**6) Floors** Floors should be cement, painted with a USDA approved, dairy grade paint, and sloped to central drain. Channel-like drains used in dairies work well, although they need not be wider than 6 inches. Before entering the drain-field, a screened basket is fashioned out of metal

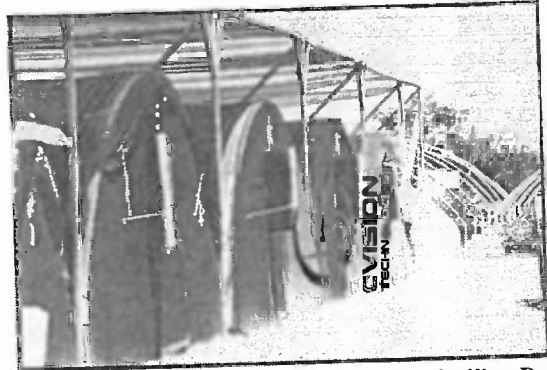

Figure 394. A Texas Reishi production facility. By modifying hoop-framed greenhouses and covering them with an open-sided, metal roofed super-structure growing rooms can be constructed at low cost.

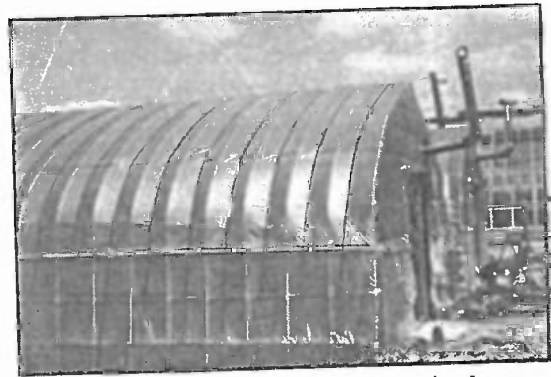

Figure 395. A Japanese mushroom growing house.

mesh to prevent clogging. This basket should be easily removed for daily cleaning. Once every several days, a cup of bleach is washed into the drain to discourage flies from breeding.

Many cultivators install a foot bath prior to each growing room to disinfect footwear. (Shoes are a major vector of contamination of soil-borne diseases into the growing rooms.) These foot baths are built into the cement slab before pouring so that a drain can be installed. A 2 ft. x 3 ft. x 2 in. recessed foot bath is ideal. The drain is capped and filled water. Bleach (chlorine) is added as a disinfectant. Placing a plastic, metal, or sponge-like grate helps re-

move debris from the feet and enhances the effectiveness of the foot bath.

**7) Rate of air exchange** Air exchanges control the availability of fresh oxygen and the purging of carbon dioxide from the respiring mushroom mycelium. High air exchange rates may adversely affect humidity, especially prior to and at primordia formation when there aerial mycelium abounds. Should aerial mycelial die back, or “pan”, potential yields are substantially depressed. On the other hand, to prevent malformation of the fruitbody, bacterial blotch, and mold infestation, the movement of air—*turbidity*—is a substantial factor in preventing disease vectors.

The need for adequate air exchange is a direct reflection of the species being grown, its rate of metabolism (as measured by CO<sub>2</sub> generation), and the “density of fill”. Fast-growing, tropical strains generate more CO<sub>2</sub> than cold weather strains due to their higher rate of metabolism. The density of fill is the fraction of space occupied by substrate vs. the total volume of the growing room. Button mushrooms growers often fill up to 1/4 of the growing room space with substrate. This high rate of fill is impractical with most gourmet mushrooms. I recommend filling the growing rooms to no more than 1/6th, and preferably 1/8th of capacity.

At 1000 cubic feet per minute (cfm) of free air delivery, an *empty* 10,000 cubic foot room, will be exchanged every 10 minutes, equivalent to 6 air exchanges per hour. This rate of air exchange is near to the minimum required for gourmet mushroom cultivation. At 2000 cfm, this same room will be exchanged every 5 minutes, or 12 air exchanges per hour. I recommend designing growing rooms which can operate within this rate of air exchange, i. e. between 6-12 air exchanges per hour. The actual rate of air exchange

will be affected by the rate of fill and limited by the avenues of exhaust. The growing rooms should always remain positive-pressurized to limit contamination vectors from the outside. A strip of cloth or plastic above the door jam works well as a simple, visual indicator of positive pressurization.

A 400-600 cfm thermal exhaust fan is recommended for a growing room of the above-described dimensions. This fan is typically located at the apex of the growing room, opposite the incoming air. A thermostat, preset by the cultivator to skim off excess heat, activates this fan. Another fan, which I call a “vortex fan” having a 200-400 cfm capacity, is located below the thermal exhaust fan, usually at head level, above the exit door. The vortex fan helps enhance the cyclonic entrainment of the air as it moves down the growing room. Both fans should be covered, *from the inside*, with a bug-proof, non-mildewing cloth. This cloth will prevent the entry of insects when the fans are not in operation. Furthermore, the thermal exhaust and vortex fan should have louvered shutters that close when not in use.

This is but one configuration of a growing room. Ideally, the growing room environment acts as a giant wind tunnel, providing a homogeneously mixed atmosphere. Simplicity of design makes operation easy. Each growing room should be independently controlled so that crops can be cycled and managed according to their stage of development.

**8) Filtration of fresh air supply** Fresh air is brought in from the outside and passed through a series of filters. The growing rooms do not require the degree of filtration that is necessary for the laboratory. Since the growing room will, at times, have full air exchanges of 4-10 times per hour, the filters must have sufficient carrying ca-

capacity. Air is first filtered through a standard Class 2 pre-filter. These filters are relatively coarse, filtering particles down to 10 microns with 30% efficiency. Pre-filters are disposable and should be replaced regularly, in most cases every one to three months. The next filter is usually electrostatic. Electrostatic filters vary substantially in their operating capacities and airflow parameters. Typically, particulates are filtered down to 1 micron with 95% efficiency. Electrostatic filters can be removed, periodically, for cleaning with a soapy solution. Their performance declines as dust load increases. For most growing rooms of 10,000 to 20,000 cubic feet, a 25 x 20 x 6 in. electrostatic filter suffices when combined with a fan sending 1000-2000 cubic feet per minute airstream into each growing room. See Figure 390 for the location of these filters.

**9) Filtration of recirculated air** Recirculated air from a growing room is relatively free of airborne particulates during the colonization phase. When the cropping cycle begins, the air becomes thick with mushroom spores. (This is especially the case with Oyster mushrooms and much less so with Button mushroom cultivation.) I have seen the spore load of Oyster mushrooms become so dense as to literally stop the rotation of high volume cfm fans!

The design of an air system should allow partial to full recirculation of the air within the growing room. Usually, a recirculation duct is centrally located directly below the incoming air. A damper door controls the degree of recirculation. If the recirculated air is passed through filters, these filters will quickly clog with mushroom spores, and airflow will radically decline. If electing to use filters, they should be changed every day during the cropping cycle. A simple way of cleaning the recirculated air is to position mist nozzles in the recirculation duct-work.

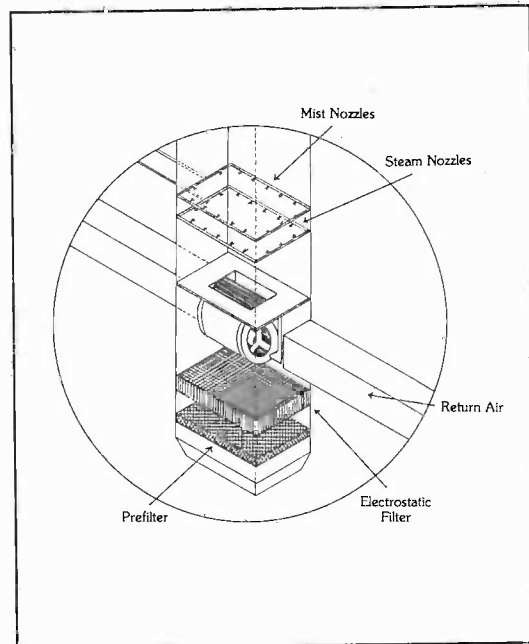

**Figure 396.** Close-up of air supply system for growing rooms featured in Figure 393. Air enters from below, passing through a coarse and an electrostatic air filter. A large squirrel cage blower pushes air into main duct system where two "rain trees" allow the introduction of cold or hot water into the airstream. In-house thermostats coupled to solenoid valves regulate the cold or hot (steam) water supply. Recirculation shutters enter the plenum from the side. The degree of recirculation can be controlled within the growing rooms. Pre-conditioning the air quality to 70-80% of desired levels is recommended before entry into the growing rooms. Provisions for excess condensation must be engineered into system.

The air will be largely rinsed clean of their spore load from the spray of water. Ideally, these downward-flowing nozzles are located directly above a drain. Having spray nozzles located below the inside roof line and misting downwards will also facilitate the downward flow of spores to the floor. This concept can have many permutations.

**10) Humidification** With the 6-12 air ex-

changes per hour required during the primordia formation period, full humidification within the growing room is difficult if drawing in dry, outside air. This problem is solved through the conditioning of outside air in an intermediate chamber called a *preconditioning plenum*. The preconditioning plenum is usually located outside of the growing room. Its purpose is to elevate humidity and alter temperature to levels adjustable by the in-room environmental systems. One preconditioning plenum can supply several growing rooms, if properly designed.

In cold climates or during the cold winter months, the preconditioning plenum can be largely humidified using steam. Steam provides both moisture and heat. Thermostats located in the preconditioning plenum and/or growing room activate solenoid valves on live steam lines coming from an on-duty boiler. Steam is sent downstream to a square-shaped grid of interconnected pipes. Holes have been drilled to orient the flow of steam towards the center. The main air system blower pushes the steam from the preconditioning box into the growing rooms. Each growing room has its own high volume axial fan which inflates the ducting and distributes the humidified, and heated air. Since moisture will collect in the polyethylene ducting, provisions must be made for removing this condensate. The simplest solution is to slant the duct at a slight angle. The condensation can then drip directly into the channel drain running lengthwise down the center of the room. (See Figure 393.)

When temperature in the growing room exceeds prescribed levels, the thermostat will close the in-line solenoid valve. Humidity will fall. A humidistat sensing the humidity in the preconditioning plenum takes control, opening a separate solenoid valve, sending cold water down-line, activating the mist nozzles. The

cold water lines should be positioned in a fashion so that they are not damaged when the steam lines are in operation. The goal here is to elevate humidity to 75-80% rH. Independent humidifiers or mist nozzles located high in the growing rooms control the remaining 25% of the humidity required for primordia formation. Some companies offer systems which utilize compressed air (100-400 psi) misting systems that emanate a fog-like cloud of humidity. With proper filtration and maintenance these systems work equally as well although typically are much more expensive to install.

Swamp coolers generate humidity and lower temperature of the incoming air. They work especially well when the outside air temperature is high and the humidity is low. These types of evaporative coolers can also be incorporated into the design of a preconditioning box. Heat exchangers must be carefully engineered for maximum effect. The cultivator is encouraged to consult a reputable HVAC (Heating, Ventilation & Air Conditioning) specialist before installation of any of the above-mentioned systems. Often times, independent systems with manual-control over-rides perform better, in the long run, than all-in-one packages. The cultivator must have alternatives for humidity should equipment fail for any reason. The value of one saved crop can easily offset the expense of a simple back-up system.

**11) Insect control** Flies are the bane of the mushroom cultivator. Once introduced, a single, pregnant fly can give rise to hundreds of voracious offspring in a few weeks. (For a complete description of the flies and their life cycles, please consult *The Mushroom Cultivator* (1983) by Stamets & Chilton.) Many models of insect traps are available. "Bug zappers" electrocute flies when they come in

between two oppositely charged metal screens. Many of the flies endemic to mushroom culture are minute and pass, unaffected, between the electrified panels. I prefer circular bug lights which use an interior fan. A cone shaped vortex is formed well beyond the light. The bugs are thrown into a plastic bag which allows for easy counting by the growing room manager. By attaching yellow sticky pads to the lights, the number of flies that can be caught greatly increases. (See Figure 384). Astute managers rely on the increasing numbers of flies as an indication of impending disaster. These lights should be positioned on or beside every door within the growing room, and especially in the rooms prior to the growing rooms. Many of the fly problems can be circumvented through some of the good practices described below.

## Managing the Growing Rooms: Good Habits for the Personnel

Integral to the success of a mushroom farm is the daily management of the growing rooms. The environment within the growing room is constantly in a dynamic state of change. Events can quickly cascade, drastically, and sometimes inalterably, affecting the outcome of the crop. The daily activities of the personnel especially impact the quality of the crop. The head cultivator can perfectly execute his or her duties only to have employees unwittingly sabotage the crop. In many cases, a simple redirection of the sequence of activities can correct the problem. By consistently following well defined rules of conduct, the growing rooms can function to their fullest potential. I recommend establishing a daily & weekly schedule that defines the activities of the personnel. By following a calendar, the crew

becomes self-organizing according to the days of the week.

**1) Maintain personal hygiene.** Shower every day. Wear newly laundered clothes. Avoid contact with molds, soils, pets, etc. Body odors are a result of growing colonies of bacteria. Those with poor personal hygiene threaten the stability of a farm. If employees can not maintain good personal hygiene, then they must be fired.

**2) Keep the property clean.** Particular emphasis should be on removing any organic debris that accumulates directly after a production run or harvest. All excess materials should be placed in a specifically allocated, dry storage location. Waste materials should be composted a safe distance away from the production facility.

**3) Minimize contact between growing room managers and pickers or other workers.** Growing room managers present the same problem doctors do in hospitals: they spread disease. All personnel should wash their hands several times a day and/or wear gloves. The growing room manager should point out contamination for workers to remove. The growing room manager, unless alone, should not handle contaminants. Furthermore, laboratory personnel and growing room personnel should not share the same lunch room, a common site for the re-distribution of contaminants.

**4) Use foot-baths** Step in disinfectant foot-baths prior to going into each growing room. Change baths daily.

**5) Frequently wash down growing rooms** The activity most affecting the maintenance of a growing room is its thorough washing down once in the morning and once in the evening. After spraying the ceilings, walls, and floors with water (untreated), any debris is directed to the central drain channel, collected, and removed.

---

After washing, the growing room feels fresh.

**6) Record maximum/minimum/ambient temperature at the same time each day.** Temperature profiling at different elevations is deemed necessary only in poorly insulated rooms. With turbulent air circulation, in a highly insulated environment, temperature stratification is minimized. Manual temperature readings should occur at the same time every day. If constant-duty chart recorders or computer sensing systems are in place, they should be reviewed daily and compared. Ambience of temperature within 3-5° F. is preferred.

**7) Charting relative humidity.** Relative humidity requirements change with each species, each day. Charting humidity can be a valuable tool in training the growing room manager to delicately balance the environment in favor of mushroom formation & development, but limiting the growth of molds. Wood-based

substrates are particularly susceptible to green mold growth if humidity is too high directly after removal of the blocks from the soaking tank. For instance, Shiitake blocks benefit from a fluctuating humidity environment whereas Oyster mushrooms require sustained 90% + humidity.

**8) Dispose of contamination once a day.** Once you have handled contamination, consider yourself contaminated. If removing *Trichoderma* (green mold) contaminated blocks of Shiitake, that person is then unworthy of any activity where susceptible substrates would be encountered. For many growers, this mandates that contaminated cultures be disposed at the end of the day. If contamination must be dealt with early in the work day, a person non-essential to the production stream should be the designated disposer of contaminated cultures.

---





## Resource Directory

**T**he following resource directory is not an endorsement of any organization, company, individual, or author. The sole intent is to give the reader the broadest range of resources so that mushrooms can be grown successfully. Omissions of any group is probably not intentional. If the reader knows of any resource that should be listed, feel free to write to this author so that future editions of *Growing Gourmet & Medicinal Mushrooms* might include them.

### Recommended Mushroom Field Guides

Cultivators must constantly return to nature for new strains. If mushrooms are not properly identified, the cultures will be inaccurately labelled. Once these cultures are passed on to other individuals, the mis-identification may not be discovered for years, if ever. An excellent example of this is what happened with cultures of “*Pleurotus sajor-caju*”, most of which are in fact *P. pulmonarius*. (See the discussion of the taxonomy of *P. pulmonarius* on page 321.) Cultivators

are encouraged to photograph the wild mushroom in fresh condition, retain a dried specimen, and make notes about its location and habitat. Without this data, accurately identifying the mushroom (and therefore the culture) will be difficult.

The following field guides are designed primarily to help amateurs in the field. Professional mycologists (although some hesitate to admit it) refer to these manuals also, particularly when they need a quick overview of the species complexes. Scientific monographs are ultimately used for confirming the identity of a mushroom to species. Amateurs should be fully aware that even professional mycologists make mistakes.

*All that the Rain Promises & More* by David Arora, 1991, 264 pages. Ten Speed Press, Berkeley.

*The Audubon Society Field Guide to North American Mushrooms* by Gary Lincoff, 1991, 926. A. A. Knopf, New York.

*A Field Guide to Southern Mushrooms* by Nancy Smith Weber & Alexander H. Smith, 280 pages. University of Michigan Press, Ann Arbor.

*A Field Guide to Western Mushrooms* by Alexander Smith, 280 pages. University of Michigan Press, Ann Arbor.

*Fungi of Japan* by R. Imazeki et al., 1988, 624 pages. Yama-Kei Publishers, Tokyo. \*

*Mushrooms of the Adirondacks, A Field Guide* by Alan E. Bessette, 1988. 145 pages. North Country Books, Utica, N. Y.

*Mushrooms Demystified* by David Arora, 1986, 959 pages. Ten Speed Press, Berkeley.

*The Mushroom Hunter's Field Guide* by Alexander Smith & Nancy Smith Weber, 1980. University of Michigan Press, Ann Arbor.

*The New Savory Wild Mushroom* by Margaret McKenny, Daniel E. Stuntz, ed. by Joseph Ammirati, 1987, 249 pages. University of Washington Press, Seattle.

---

\* This field guide, although in Japanese, is probably one of the best, if not the best field guide published to date. The photography is *exceptional*. I highly recommend and admire this volume.

---

## Mushroom Book Suppliers

### Fungi Perfecti

(360) 426-9292 FAX: 360-426-9377  
e-mail: mycomedia@aol.com  
(Field Guides, Cultivation Books, General  
Treatises)  
P.O. Box 7634  
Olympia, WA. 98507

### FS Book Company

(General Books)  
P.O. Box 417457  
Sacramento, CA. 95841-7457

### Lubrecht & Cramer, Ltd

(914) 794-8539  
(General & Erudite Monographs)  
38 County Rte. 48  
Forestburgh, N.Y. 12777

### Mad River Press

(707) 443-2947  
(General, Publisher of Mycological Texts)  
141 Carter Lane  
Eureka, CA. 95501

### MushroomPeople

(615) 964-2200  
P.O. Box 220  
Summertown, TN. 38483-0220

### Mycologue Publications

331 Daleview Place  
Waterloo, Ontario N2L 5M5  
Canada

### Mycophile Books

P.O. Box 93  
Naples, FL. 33940

### Raymond M. Sutton, Jr.

Mycology Books  
430 Main St.  
Williamsburg, KY. 40769

## Annual Mushroom Festivals & Events

Many of the mycological societies stage annual mushroom exhibits. Here is a short list of some of the more notable annual mushroom exhibitions. Most are held in September or October unless otherwise indicated. Please contact them for more specific information.

### Asheville Annual Labor Day Mushroom Foray

(Early September)  
Nature Center, Gashes Cr. Rd.  
Asheville, N.C.

### Boyne City's Mushroom Festival

(616) 582-6222  
(Early May)  
Boyne City Chamber of Commerce  
Boyne City, MI.

---

**Colorado Mycological Society Mushroom Show**

(Mid-August)  
P.O. Box 9621  
Denver, CO. 80209-0621

**Gulf States Mycological Society Foray**

(Mid-July)  
University of Mississippi, Gulfport  
c/o Dr. Bill Cibula & Anna Pleasanton  
1000 Adams St.  
New Orleans, LA. 70118

**Humboldt Bay Mycological Society**

(Mid-November)  
P.O. Box 4419  
Arcata, Ca. 95521-1419

**Lincoln County Mushroom Society**

(Mid-October)  
207 Hudson Loop  
Toledo, OR. 97391

**Mount Pisgah Arboretum Fall Festival & Annual Mushroom Show**

(Mid-October)  
Eugene, OR.

**Mycological Society of San Francisco**

Annual Mushroom Show  
P.O. Box 882163  
San Francisco, CA. 94188-2163

**Oregon Mycological Society Annual Fall Mushroom Show**

(Mid-October)  
c/o Maggie Rogers  
1943 S.E. Locust  
Portland, OR. 97214

**Puget Sound Mycological Society Annual Mushroom Exhibit**

(Mid-October)  
University of Washington  
Urban Horticulture  
GF-15  
Seattle, WA. 98195-0001

**Richmond's Annual Mushroom Festival**

(1st weekend of May)  
c/o Richmond Chamber of Commerce  
108 West Main  
Richmond, MO. 64085

**The Santa Cruz Fungus Fair**

Fungus Federation of Santa Cruz  
1305 E. Cliff St.  
Santa Cruz, CA. 95062-3722

**Spokane Mycological Society's Priest Lake Foray**

(Late September)  
P.O. 2791  
Spokane, WA. 99220-2791

**Vancouver Mycological Society Mushroom Show**

(Mid-October)  
c/o Van Deusen Botanical Gardens  
Paul Kroeger (604) 322-0074  
395 E. 40th Ave  
Vancouver, B.C. V5W 1M1 Canada

**Wild Mushrooms: Telluride**

(303) 296-9359  
(Late August)  
Fungophile, Inc.  
P.O. Box 480503  
Denver, CO. 80248-0503

---

## **Mushroom Cultivation Seminars & Training Centers**

### **Arunyik Mushroom Center**

( Fax: 662-441-9246)  
Mr. Satit Thaithatgoon  
P.O. Box 1  
Bangkok 10162  
Thailand

### **Centrum voor Champignonteelt odnerwijs (CCO)**

Westerholtstraat 2  
Horst (L) 5640  
Holland

### **Forest Resource Center**

(507) 467-2437  
1991 Brightsdale Rd  
Rte. 2 Box 156 A  
Lanesboro, MN. 55949

### **International Mushroom School**

(051/893-768)  
Mushroom Information  
OK Press S. R. L.  
Via Poggiorenatico, 2  
40016 San Giorgio di Piano (Bo) Italy

### **Mushroom Society of India**

National Centre for Mushroom Research  
& Training  
Chambaghat, Solan 173213 (H. P.) India

### **Pennsylvania State University Short Course**

Agricultural Short Course Office  
College of Agriculture  
The Pennsylvania State University  
210 Buckhout Laboratory  
University Park, PA. 16802-4507

### **The Stamets Seminars**

(360) 426-9292 Fax (360) 426-9377  
c/o Fungi Perfecti  
P.O. Box 7634  
Olympia, WA. 98507

## **Mushroom Study Tours/Adventures**

### **David Arora's International Mushroom Adventures**

c/o David Arora (408) 425-0188  
343 Pacheco Ave  
Santa Cruz, CA. 95062

### **Adirondack Mushroom Weekends**

(315) 792-3132  
c/o Alan Bessette  
Utica College of Syracuse University  
1600 Burrstone Rd  
Utica, N.Y. 13502

### **Gerry Miller's Amazon Forays**

(203) 873-8286  
Box 126  
East Haddam, CT. 06423

### **Fungophile's Mushroom Study Tours**

w/ Gary Lincoff & Dr. Emanuel Salzman  
P.O. Box 480503  
Denver, CO. 80248

### **North American Mycological Association**

3556 Oakwood Drive  
Ann Arbor, MI. 48104-5213

---

## **International Mushroom Associations**

**International Mycological Association**  
CAB International Mycological Institute  
Ferry Lane, Kew  
Surrey, TW9 3AF  
United Kingdom

**International Society for Mushroom Science**  
50 St. Flora's Rd.  
Littlehampton, West Sussex  
England BN17 6BB  
United Kingdom

**Associazione Micologica Bresadola**  
Via S. Croce 6  
C.P. 396, 38100  
Trento, Italy

## **North American Mushroom Societies & Associations**

**Arkansas Mycological Society**  
4715 W. Hensley Rd.  
Hensley, AR. 72065

**Alaska Mycological Society**  
P.O. Box 2526  
Homer, AK. 99603-2526

**Albion Mushroom Club**  
Whitehouse Nature Center  
Albion, MI. 49224

**Arkansas Mycological Society**  
5115 S. Main St  
Pine Bluff, AR. 71601-7452

**Asheville Mushroom Club**  
Nature Center  
Gashes Cr Rd  
Asheville, N.C. 28805

**Berkshire Mycological Society**  
Pleasant Valley Sanctuary  
Lenox, MA. 01240

**Blue Ridge Mushroom Club**  
PO Box 2032  
North Wilkesboro, N.C. 28659-2032

**Boston Mycological Club**  
855 Commonwealth Ave  
Newton Centre, MA. 02159

**Central New York Mycological Society**  
343 Randolph St  
Syracuse, N.Y. 13205-2357

**Cercle des Mycologues de Montreal**  
4101 E. Rue Sherbrooke, # 125  
Montreal, P.Q.  
Canada

**Cercle des Mycologues de Rimouski**  
University of Quebec  
Rimouski, P.Q.  
Canada

**Cercle Mycologues de Quebec**  
Pav. Comtois  
Univ. Laval  
Ste. Foy, P.Q.  
Canada

**Cercle des Mycologues du Saguenay**  
438 Rue Perrault  
Chicoutimi, P.Q.  
Canada

---

**Chibougamau Mycological Club**

804 5e Rue  
Chibougamau, P.Q.  
Canada

**Colorado Mycological Society**

P.O. Box 9621  
Denver, CO. 80209

**COMA**

Connecticut-Westchester Mycological  
Association  
c/o Sandy Sheine  
93 Old Mill River Road  
Pound Ridge, N.Y. 10576-1833

**Connecticut Valley Mycological  
Association**

c/o Marteka  
Jobs Pond Rd  
Portland, CT. 06480

**Fungus Federation of Santa Cruz**

1305 E. Cliff Dr  
Santa Cruz, CA. 95062-3722

**Gulf States Mycological Society**

1000 Adams St  
New Orleans, LA. 70118-3540

**Humboldt Bay Mycological Society**

P.O. Box 4419  
Arcata, CA. 95521-1419

**Illinois Mycological Association**

4020 Amelia Ave  
Lysons, IL. 60534

**Kaw Valley Mycological Society**

601 Mississippi St.  
Lawrence, KS. 66044

**Kitsap Peninsula Mycological Society**

P.O. Box 265  
Bremerton, WA. 98310-0054

**Lewis County Mycological Society**

196 Taylor Rd. S.  
Chehalis, WA. 98532

**Lincoln County Mycological Society**

207 Hudson Loop  
Toledo, OR 97391

**Los Angeles Mycological Society**

Biology Dept.  
5151 State University Drive  
Los Angeles, CA. 90003

**Lower East Shore Mushroom Club**

RR. 1 Box 94B  
Princess Anne, MD. 21853-9801

**Maine Mycological Society**

c/o Sam Ristich  
81 Sligo Rd.  
N. Yarmouth, ME. 04021

**Michigan Mushroom**

**Hunters Association**  
15223 Marl Dr.  
Linden, MI. 48451

**Mid Hudson Mycological Association**

43 South St  
Highland, N.Y. 12528

---

**Minnesota Mycological Society**

7637 East River Rd.  
Fridley, MN. 55432

**Missouri Mycological Society**

2888 Ossenfort Rd  
Glencoe, MO. 63038

**Montshire Mycological Club**

c/o Carlson  
P.O. Box  
Sunapee, N.H. 03782

**Mount Shasta Mycological Society**

623 Pony Trail Rd  
Mount Shasta, CA. 96067

**Mycological Association of Washington**

12200 Remington Drive  
Silver Springs, MD. 20902

**Mycological Society of America**

Iris Charvat  
220 Biosci Center  
University of Minnesota  
St. Paul, MN. 55108

**Mycological Society of San Francisco**

P.O. Box 882163  
San Francisco, CA. 94188-2163

**Mycological Society of Toronto**

4 Swallow Court  
New York, Ontario  
Canada

**Mycological Society of Vancouver**

403 3rd St. c/o Tamblin  
New Westminster, B.C.  
Canada

**New Jersey Mycological Society**

1187 Millstone River Rd  
Somerville, N.J. 08876

**New Hampshire Mycological Society**

84 Cannongate III  
Nashua, N.H. 03063

**New Mexico Mycological Society**

1511 Marble Ave. NW  
Albuquerque, N.M. 87104

**New York Mycological Society**

c/o Lynn Payer  
720 W. 181st #54  
New York, N.Y. 10033

**North American Mycological Association**

3556 Oakwood Drive  
Ann Arbor, MI. 48104

**North American Truffling Society**

PO Box 296  
Corvallis, OR. 97339

**North Idaho Mycological Association**

E. 2830 Marine Drive  
Post Falls, ID. 83854

**Northwestern Mushroomers Association**

831 Mason St c/o Marlowe  
Bellingham, WA. 98225-5715

**Northwestern Wisconsin  
Mycological Society**

311 Ash St.  
Frederic, WI. 54837

---



**Nutmeg Mycological Society**

c/o Kovak  
191 Mile Creek Rd  
Old Lyme, CT. 06371

**Ohio Mycological Society**

10489 Barchester Dr.  
Concord, OH. 44077

**Olympic Mountain Mycological Society**

PO Box 720  
Forks, WA. 98331-0720

**Oregon Coast Mycological Society**

P.O. Box 1590  
Florence, OR. 97439

**Oregon Mycological Society**

14605 S. W. 92nd Ave  
Tigard, OR. 97224

**Pacific Northwest Key Council**

1943 SE Locust Ave  
Portland, OR. 97201-2250

**Parkside Mycological Club**

5219 85th ST  
Kenosha, WI. 53142-2209

**Prairie States Mushroom Club**

310 Central Drive  
Pella, IA. 50219-1901

**Puget Sound Mycological Society**

Center for Urban Horticulture  
GF-15 University of Washington  
Seattle, WA. 98195

**Rochester Area Mycological Association**

54 Roosevelt Rd.  
Rochester, N.Y. 14618-2933

**Snohomish Mycological Society**

Box 2822 Claremont Station  
Everett, WA. 98203

**Sonoma County Mycological Association**

1218 Bennett Lane  
Calistoga, CA. 94515

**South Idaho Mycological Association**

P.O. Box 843  
Boise, ID. 83701

**South Sound Mushroom Club**

c/o Ralph & Bonnie Hayford  
6439 32nd Ave  
Olympia, WA. 98507

**Spokane Mushroom Club**

N. 2601 Barder Rd. Sp. 5  
Otis Orchards, WA. 99027

**Tacoma Mushroom Club**

P.O. Box 99577  
Tacoma, WA. 98499-0577

**Texas Mycological Society**

7445 Dillon  
Houston, TX. 77061

**Triangle Area Mushroom Club**

P.O. Box 61061  
Durham, N.C. 27705

**Vancouver Mycological Society**

403 Third St.  
New Westminster, B.C.  
Canada

**Wenatchee Valley Mushroom Society**

287 N. Iowa Ave.  
East Wenatchee, WA. 98802

---

**West Michigan Mycological Society**

923 E. Ludington Ave  
Ludington, MI. 49431

**Willamette Valley Mushroom Society**

2610 East Nob Hill SE  
Salem, OR. 97303

**Wisconsin Mycological Society**

800 W. Wells St. Rm. 614  
Milwaukee, WI. 53233

## Mushroom Growers' Associations

Many of the previously listed mycological societies have established "Cultivation Committees" which organize members interested in mushroom cultivation. The following organizations are independent of any mycological society.

**Alabama Shiitake Grower's Association**

(205) 532-1697  
c/o Hosea Nall  
Cooperative Extension Service  
Alabama A & M University  
819 Cooke Ave.  
Normal, AL. 35762

**American Mushroom Institute**

(215)388-7806  
907 East Baltimore Pike  
Kennett Square, PA. 19348

**Appalachian Mushroom Growers' Association**

c/o Margey Cook  
Rt. 1 Box BYY  
Haywood, VA. 22722

**Canadian Mushroom Growers' Association**

310-1101  
Prince of Wales Drive  
Ottawa, Ontario K2C 3W7  
Canada

**Carolina Exotic Mushroom Association**

c/o Ellie Litts  
P.O. Box 356  
Hodges, S. C. 29653

**Florida Mushroom Growers Association**

c/o Charlie Tarjan  
3426 S.W. 75th St.  
Gainesville, FL. 32607

**Northwest Shiitake Growers Association**

P.O. Box 207  
Salem, OR. 97308

**SHIIGAW**

Shiitake Growers Association of Wisconsin  
P.O. Box 99  
Birchwood, WI. 54817

## Sources for Mushroom Cultures

**American Type Culture Collection**

12301 Parklawn Drive  
Rockville, MD. 20852-1776  
USA

**Arunyik Mushroom Center**

P.O. Box 1 Nongkhaem  
Bangkok 10162  
Thailand

---

**Centre for Land & Biological Research**

Research Branch, Agriculture Canada  
Ottawa, Ontario K1A 0C6  
Canada

**Collection of Higher**

**Basidiomycetes Cultures**

Komarov Botanical Institute  
Academy of Sciences  
Leningrad, Russia

**Culture Collection of Fungi**

Commonwealth Mycological Institute  
Kew, Great Britain

**Culture Collection of Basidiomycetes**

Department of Experimental Mycology  
Videnska 1083, 142 20 Praha 4 Krc.  
Czechoslovakia

**Forest Research Institute**

Private Bag  
Rotorua, New Zealand

**Forintek Canada Corporation**

800 Chemin Montreal Rd.  
Ottawa, Ontario  
Canada K1G 3Z5

**Fungi Perfecti**

360-426-9292  
(Catalogue \$ 4.50 U.S. Funds)  
Stamets Culture Collection  
P.O. Box 7634  
Olympia, WA. 98507  
USA

**Instituto de Ecologia, A. C.**

AP 63 K. M. 2. 5 Antigua Carretera  
A Coatepec  
Xalapa, Veracruz  
Mexico

**INRA**

Station de Recherches sur les Champi-  
gnons  
Villenave D'Ormon  
France

**Institute for Fermentation**

17-85 Juso-honmachi 2-chome  
Yodagawa-ku  
Osaka 532  
Japan

**Japanese Federation of  
Culture Collections**

Tokyo Agriculture College  
Sakuragaoka 1-1-1  
Setagaya-ku Tokyo 156  
Japan

**Mushroom Research Centre**

Huettenallee 235  
4150 Krefeld  
West Germany

**Mushroom Kingdom Labs**

P.O. Box 901  
Elkin, NC 28621

**National Type Culture Collection**

Forest Pathology Branch  
Forest Research Institute & Colleges  
Dehra Dun  
India

**Pennsylvania State University**

Mushroom Research Station  
Buckhout Laboratory  
University Park, PA. 16802  
USA

---

**Somycel**

Centre de Recherches sur les Champignons  
Langeais  
France

**Tottori Mycological Institute**

Furukage 211  
Tottori, 689-11  
Japan

**Sources for  
Mushroom Spawn**

**Alpha Spawn**

(215) 268-2018  
R.D. #1, Box 34  
Avondale, PA. 19311

**Amycel, Inc.**

553 Mission Vineyard Rd.  
P.O. Box 1260  
San Juan Bautista, CA. 95045

**Field & Forest Products**

(715) 582-4997  
N 3296 Kozuzek Rd.  
Peshtigo, WI. 54157

**Fungi Perfecti**

(360) 426-9292/FAX (360) 426-9377  
Catalogue \$ 4.50 U. S. funds.  
P.O. Box 7634  
Olympia, WA. 98507

**Gourmet Mushrooms**

P.O. Box 515  
Graton, CA. 95444

**International Spawn Laboratory**

Beechmount, Navan  
Co. Meath, Ireland

**Lambert Spawn**

(215) 384-5031  
P.O. Box 407  
Coatesville, PA. 19320

**Longwood Biological Laboratories**

(215) 869-3950  
Hepburn Rd. RR. 2 Box 475  
Avondale, PA. 19311

**Morel Mountain**

(617) 676-6373  
(Fresh & Dried Morels, Outdoor Morel  
Spawn)  
P.O. Box 158  
Mason, MI. 48854

**MushroomPeople**

(615) 964-2200  
(Shiitake Spawn & Inoculation Equip-  
ment, Books)  
P.O. Box 220  
Summertown, TN. 38483-0220

**Northwest Mycological Consultants**

(503) 753-8198  
702 NW 4th St  
Corvallis, OR. 97330

**Rainforest Mushroom Spawn**

(604) 886-7799  
P.O. Box 1793  
Gibsons, B.C. V0N 1V0  
Canada

---

**J. B. Swayne Spawn**  
 (215) 444-0888  
 87 Lakes Blvd.  
 Dayton, NV. 89403

**Sylvan Spawn**  
 87 Lakes Blvd.  
 Dayton, NV 89403

## **Growers' Associations & Sources for Marketing Information**

**American Mushroom Institute**  
 (215) 388-7806  
 907 East Baltimore Pike  
 Kennett Square, PA. 19348

**Appalachian Mushroom Growers, Inc.**  
 Rt. 1 Box 30  
 Haywood, VA. 22722

**Canadian Mushroom  
 Grower's Association**  
 310 - 1101 Prince of Wales Drive  
 Ottawa, Ontario K2C 3W7  
 Canada

**The Mushroom Growers' Newsletter**  
 c/o The Mushroom Company  
 P.O. Box 5065  
 Klamath Falls, OR. 97601

**Mushroom Grower's Association of Great  
 Britain & N. Ireland**  
 Agriculture House  
 Knightsbridge, London SW1X 7Nj  
 England

**National Agricultural Statistics Service**  
 ERS/NASS  
 United States Dept. of Agriculture  
 (800-727-9540)  
 "Mushrooms" (National marketing trends)  
 P.O. Box 1608  
 Rockville, MD. 20849-1608

**Northwest Shiitake Grower's Association**  
 PO Box 207  
 Salem, OR. 97308

**SHII-GAW**  
 Shiitake Growers Association of  
 Wisconsin  
 P.O. Box 99  
 Birchwood, WI. 54817

## **Mushroom Newsletters & Journals**

**Cultivated Mushroom Report**  
 University of Toronto  
 Mississauga, Ontario  
 Canada

**Fungiflora A/S**  
 PO Box 95  
 Blindern  
 N-0314 Oslo 3  
 Norway

**McIlvainea, Journal of Amateur  
 Mycology & The Mycophile**  
 North American Mycological Association  
 3556 Oakwood  
 Ann Arbor, MI. 48104-5213

---

**The Mushroom Growers' Newsletter**

c/o The Mushroom Company  
P.O. Box 5056  
Klamath Falls, OR. 97601

**Mushroom Information**

La Rivista del Fungicoltura Moderno  
40016 S. Giorgio di Plano (BO)  
Postale Grupo III/70  
Bologna, Italy

**Mushroom, The Journal**

Box 3156  
Moscow, ID. 83843

**Mushroom Journal of the Tropics**

The International Mushroom Society for  
the Tropics,  
c/o Department of Botany,  
Chinese University of Hong Kong  
Shatin, New Territories, Hong Kong

**Mushroom News**

American Mushroom Institute  
(215) 388-7806  
907 East Baltimore Pike  
Kennett Square, PA. 193587

**Mushroom Research**

International Journal of Research  
& Development  
National Centre for Mushroom Research  
& Training  
Chambaghat, Solan 173 213 (HP)  
India

**Mycologia**

Official Publication of the  
Mycological Society of America  
The New York Botanical Garden  
Bronx, N.Y. 10458

**Mycological Research**

Cambridge University Press  
North American Branch  
40 West 20th St.  
New York, N.Y. 10011-4211

**Mycotaxon**

POBox 264  
Ithaca, N.Y. 14850

**Shiitake News**

Forest Resource Center  
Rt. 2 box 156 A  
Lanesboro, MN. 55949

**Mushroom Museums**

**The Mori Mushroom Institute**

PH: 0277-22-0591  
Kiryu-shi Gumma 376  
Kiryu, Japan

**Mushroom Museum of Holland**

S. O. M. /Tweede Walstrat 99  
6511 Lr Nijmegen  
Nijmegen, 6511 Holland

---

**The Mushroom Museum at Phillips Place**  
 909 E. Baltimore Pike  
 Kennett Square, PA. 19348 USA

## Sources for Medicinal Mushroom Products



**Eclectic Institute**  
 (800) 332-4372  
 14385 S. E. Lusted Rd.  
 Sandy, OR. 97055

**Fungi Perfecti**  
 (360) 426-9292  
 P.O. Box 7634  
 Olympia, WA. 98507

**Maitake, Inc.**  
 (800) 747-7418  
 P.O. Box 1354  
 6 Aster Court,  
 Paramus, N. J. 07653

**North American Reishi**  
 (604) 886-7799  
 P.O. Box 1780,  
 Gibsons, B. C. VON 1VO.  
 Canada

**Organotech**  
 7960 Cagnon Road  
 San Antonio, TX. 78252-2202

## Mycological Resources on Internet

**Cornell WWW Virtual Library for  
 Mycologists**  
[http://muse.bio.cornell.edu/taxonomy/  
 fungi.html](http://muse.bio.cornell.edu/taxonomy/fungi.html)

**Econet**  
[http://www.igc.apc.org/igc/  
 www.myc.html](http://www.igc.apc.org/igc/www.myc.html)

**Fungi Perfecti**  
[http://www.halycon.com/mycomed/  
 fppage.html](http://www.halycon.com/mycomed/fppage.html)

**Fungus**  
<http://www.mtjeff.com/fungi>

**MushroomPeople**  
[http://www.gaia.org/farm/mushroom/  
 mp.html](http://www.gaia.org/farm/mushroom/mp.html)

**Mycelium**  
[http://www.econet.apc.org/mushroom/  
 welco.html](http://www.econet.apc.org/mushroom/welco.html)

**Mycological Society America: Inoculum  
 Newsletter**  
[gopher://nmnhgoph.si.edu/70/11/botany/  
 .myco/inoculum](mailto:gopher://nmnhgoph.si.edu/70/11/botany/.myco/inoculum)

**Mycopage**  
[http://www.inf.unitn.it/~mflorian/  
 mycopage.html](http://www.inf.unitn.it/~mflorian/mycopage.html)

**USDA**  
 National Agricultural Statistics Service  
 Mushroom Market Trends  
<http://www.usda.gov/nass/>

---





# Analysis of Basic Materials Used in Substrate Preparation

## DRY ROUGHAGES OF FIBROUS MATERIALS

Material	Total dry matter	Protein	Fat	Fiber	N-free extract	Total minerals	Calcium	Phosphorus	Nitrogen	Potassium
	Per ct.	Per ct.	Per ct.	Per ct.	Per ct.	Per ct.	Per ct.	Per ct.	Per ct.	Per ct.
Alfalfa hay, all analyses	90.5	14.8	2.0	28.9	36.6	8.2	1.47	0.24	2.37	2.05
Alfalfa hay, very leafy (less than 25% fiber)	90.5	17.2	2.6	22.6	39.4	8.7	1.73	0.25	2.75	2.01
Alfalfa hay, leafy (25-28% fiber)	90.5	15.8	2.2	27.4	36.6	8.5	1.50	0.24	2.53	2.01
Alfalfa hay, stemmy (over 34% fiber)	90.5	12.1	1.4	36.0	33.4	7.6	1.10	0.18	1.94	1.68
Alfalfa hay, before bloom	90.5	19.0	2.7	22.6	36.7	9.5	2.22	0.33	3.04	2.14
Alfalfa hay, past bloom	90.5	12.8	2.1	31.9	36.2	7.5	—	—	2.05	—
Alfalfa hay, brown	87.9	17.3	1.6	24.5	35.1	9.4	1.37	0.26	2.77	—
Alfalfa hay, black	83.1	17.5	1.5	29.1	25.3	9.7	—	—	2.80	—
Alfalfa leaf meal	92.3	21.2	2.8	16.6	39.7	12.0	1.69	0.25	3.39	—
Alfalfa leaves	90.5	22.3	3.0	14.2	40.5	10.5	2.22	0.24	3.57	2.06
Alfalfa meal	92.7	16.1	2.2	27.1	38.2	9.1	1.32	0.19	2.58	1.91
Alfalfa stem meal	91.0	11.5	1.3	36.3	34.8	7.1	—	—	1.84	—
Alfalfa straw	92.6	8.8	1.5	40.4	35.1	6.8	—	0.13	1.41	—
Alfalfa and bromegrass hay	89.3	12.4	2.0	28.6	38.1	8.2	0.74	0.24	1.98	2.18
Alfalfa and timothy hay	89.8	11.1	2.2	29.5	40.3	6.7	0.81	0.21	1.78	1.78
Alfilaria, dry ( <i>Erodium cicutarium</i> )	89.2	10.9	2.9	23.4	40.2	11.8	1.57	0.41	1.74	—
Alfilaria, dry, mature	89.0	3.5	1.5	31.4	44.1	8.5	—	—	0.56	—
Atlas sorghum stover	85.0	4.0	2.0	27.9	44.2	6.9	0.34	0.09	0.64	—
Barley hay	90.8	7.3	2.0	25.4	49.3	6.8	0.26	0.23	1.17	1.35
Barley straw	90.0	3.7	1.6	37.7	41.0	6.0	0.32	0.11	0.59	1.33
Bean hay, mung	90.3	9.8	2.2	24.0	46.6	7.7	—	—	1.57	—
Bean hay, tepary	90.0	17.1	2.9	24.8	34.7	10.5	—	—	2.74	—
Bean pods, field, dry	91.8	7.1	1.0	34.8	45.0	3.9	0.78	0.10	1.14	2.02
Bean straw, field	89.1	6.1	1.4	40.1	34.1	7.4	1.67	0.13	0.98	1.02
Beggarweed hay	90.9	15.2	2.3	28.4	37.2	7.8	1.05	0.27	2.43	2.32
Bent grass hay, Colonial	88.5	6.6	3.0	29.5	42.8	6.6	—	0.18	1.06	1.42
Bermuda grass hay	90.6	7.2	1.8	25.9	48.7	7.0	0.37	0.19	1.15	1.42
Bermuda grass hay, poor	90.0	5.8	0.9	38.8	37.7	6.8	—	—	0.93	—
Berseem hay, or Egyptian clover	91.7	13.4	2.7	21.0	42.7	11.9	3.27	0.28	2.14	2.05
Birdsfoot trefoil hay	90.5	13.8	2.1	27.5	41.2	5.9	1.13	0.22	2.35	1.52
Black grass hay ( <i>Juncus Gerardi</i> )	89.7	7.5	2.5	25.1	47.3	7.3	—	0.09	1.20	1.56
Bluegrass hay, Canada	89.3	6.6	2.3	28.2	46.4	5.8	—	0.20	1.06	1.94

498 ANALYSIS OF BASIC MATERIALS

Material	Total dry matter	Protein	Fat	Fiber	N-free extract	Total minerals	Calcium	Phosphorus	Nitrogen	Potassium
	Per ct.	Per ct.	Per ct.	Per ct.	Per ct.	Per ct.	Per ct.	Per ct.	Per ct.	Per ct.
Bluegrass hay, Kentucky, all analyses	89.4	8.2	2.8	29.8	42.1	6.5	0.46	0.32	1.31	1.73
Bluegrass hay, Kentucky, in seed	87.3	5.5	2.5	31.0	41.9	6.4	0.23	0.20	0.88	1.48
Bluegrass hay, native western	91.9	11.2	3.0	29.8	39.9	8.0	—	—	1.79	—
Bluejoint hay ( <i>Calamagrostis Canadensis</i> )	88.5	7.2	2.3	32.9	39.6	6.5	—	—	1.15	—
Bluestem hay ( <i>Andropogon</i> , spp.)	86.6	5.4	2.2	30.2	43.4	5.4	—	—	0.86	—
Bromegrass hay, all analyses	88.1	9.9	2.1	28.4	39.5	8.2	0.20	0.28	1.58	2.35
Bromegrass hay, before bloom	89.0	14.5	2.3	24.6	37.9	9.7	—	—	2.32	—
Broom corn stover	90.6	3.9	1.8	36.8	42.4	5.7	—	—	0.62	—
Buckwheat hulls	88.6	3.0	1.0	42.9	40.1	1.6	0.26	0.02	0.48	0.27
Buckwheat straw	88.6	4.3	1.0	36.2	38.8	8.3	1.24	0.04	0.69	2.00
Buffalo grass hay ( <i>Bulbilis dactyloides</i> )	88.7	6.8	1.8	23.8	46.2	10.1	0.70	0.13	1.09	1.36
Bunchgrass hay, misc. varieties	91.7	5.8	2.0	30.4	44.1	9.4	—	—	0.93	—
Carpet grass hay	92.1	7.0	2.2	31.8	40.9	10.2	—	—	1.12	—
Cat-tail, or tule hay ( <i>Typha angustifolia</i> )	90.8	5.8	1.7	30.8	44.3	8.2	—	—	0.93	—
Cereals, young, dehydrated	92.8	24.5	4.7	16.1	33.1	14.4	0.66	0.46	3.92	—
Chess, or cheat hay ( <i>Bromus</i> , spp.)	91.7	6.9	2.1	29.2	46.1	7.4	0.29	0.25	1.10	1.47
Clover hay, alsike, all analyses	88.9	12.1	2.1	27.0	39.9	7.8	1.15	0.23	1.94	2.44
Clover hay, alsike, in bloom	89.0	13.4	3.2	26.9	37.7	7.8	1.32	0.25	2.14	2.27
Clover hay, Alyce	89.0	10.9	1.6	35.4	35.5	5.6	—	—	1.74	—
Clover hay, bur	92.1	18.4	2.9	22.9	37.8	10.1	1.32	0.45	2.94	2.96
Clover hay, crimson	89.5	14.2	2.2	27.4	37.0	8.7	1.23	0.24	2.27	2.79
Clover hay, Ladino	88.0	19.4	3.2	20.7	34.9	9.8	1.32	0.29	3.10	2.78
Clover, Ladino, and grass hay	88.0	16.3	2.2	20.7	41.7	7.1	1.05	0.26	2.61	1.97
Clover hay, mammoth red	88.0	11.7	3.4	29.2	37.0	6.7	—	0.24	1.87	—
Clover hay, red, all analyses	88.1	11.8	2.6	27.2	40.1	6.4	1.35	0.19	1.89	1.43
Clover hay, red, leafy (less than 25% fiber)	88.1	13.4	3.1	23.6	40.8	7.2	—	—	2.14	—
Clover hay, red, stemmy (over 31% fiber)	88.2	10.1	2.1	34.1	36.0	5.9	0.99	0.15	1.62	1.77
Clover hay, red, before bloom	88.1	18.3	3.6	18.0	41.1	7.1	1.69	0.28	2.93	2.26
Clover hay, red, early to full bloom	88.1	12.5	3.5	26.1	39.7	6.3	1.47	0.22	2.00	1.73
Clover hay, red, second cutting	88.1	13.4	2.9	24.5	40.4	6.9	—	—	2.14	—
Clover hay, sweet, first year	91.8	16.5	2.5	24.6	39.7	8.5	1.37	0.26	2.64	1.57
Clover hay, sweet, second year	90.7	13.5	1.9	30.2	37.6	7.5	1.25	0.23	2.16	1.78
Clover hay, white	88.0	14.4	2.4	22.5	40.9	7.8	1.16	0.24	2.30	1.66
Clover leaves, sweet	92.2	26.6	3.2	9.5	41.9	11.0	—	—	4.26	—
Clover stems, sweet	92.7	10.6	1.1	38.0	35.6	7.4	—	—	1.70	—
Clover straw, crimson	87.7	7.5	1.5	38.8	32.9	7.0	—	—	1.20	—
Clover and mixed grassy, high in clover	89.7	9.6	2.7	28.8	42.2	6.2	0.90	0.19	1.54	1.46
Clover and timothy hay, 30 to 50% clover	88.1	8.6	2.2	30.3	41.2	5.8	0.68	0.20	1.38	1.47
Corn cobs, ground	90.4	2.3	0.4	32.1	54.0	1.6	—	0.02	0.37	0.37
Corn fodder, well-eared, very dry (from barn or in arid districts)	91.1	7.8	2.2	27.1	47.6	6.4	0.24	0.16	1.25	0.82
Corn fodder, high in water	60.7	4.8	1.4	16.7	34.2	3.6	0.16	0.11	0.77	0.55
Corn fodder, sweet corn	87.7	9.2	1.8	26.4	41.3	9.0	—	0.17	1.47	0.98
Corn husks, dried	85.0	3.4	0.9	28.2	49.6	2.9	0.15	0.12	0.54	0.55
Corn leaves, dried	82.8	7.7	1.9	23.9	42.6	6.7	0.29	0.10	1.23	0.36
Corn stalks, dried	82.8	4.7	1.5	28.0	43.3	5.3	0.25	0.09	0.75	0.50

Material	Total dry matter	Protein	Fat	Fiber	N-free extract	Total minerals	Calcium	Phosphorus	Nitrogen	Potassium
	Per ct.	Per ct.	Per ct.	Per ct.	Per ct.	Per ct.	Per ct.	Per ct.	Per ct.	Per ct.
Corn stover (ears removed), very dry	90.6	5.9	1.6	30.8	4.65	5.8	0.29	0.05	0.94	0.67
Corn stover, high in water	59.0	3.9	1.0	20.1	30.2	3.8	0.19	0.04	0.62	0.44
Corn tops, dried	82.1	5.6	1.5	27.4	42.0	5.6	—	—	0.90	—
Cotton bolls, dried	90.8	8.7	2.4	30.8	42.0	6.9	0.61	0.09	1.39	3.18
Cotton leaves, dried	91.7	15.3	6.8	10.3	43.5	15.8	4.58	0.18	2.45	1.36
Cotton stems, dried	92.4	5.8	0.9	44.0	37.5	4.2	—	—	0.93	—
Cottonseed hulls	90.7	3.9	0.9	46.1	37.2	2.6	0.14	0.07	0.62	0.87
Cottonseed hull bran	91.0	3.4	0.9	37.2	46.7	2.8	—	—	0.54	—
Cowpea hay, all analyses	90.4	18.6	2.6	23.3	34.6	11.3	1.37	0.29	2.98	1.51
Cowpea hay, in bloom to early pod	89.9	18.1	3.2	21.8	36.7	10.1	—	—	2.90	—
Cowpea hay, ripe	90.0	10.1	2.5	29.2	41.8	6.4	—	—	1.62	—
Cowpea straw	91.5	6.8	1.2	44.5	33.6	5.4	—	—	1.09	—
Crabgrass hay	90.5	8.0	2.4	28.7	42.9	8.5	—	—	1.28	—
Durra fodder	89.9	6.4	2.8	24.1	51.4	5.2	—	—	1.02	—
Emmer hay	90.0	.97	2.0	32.8	36.4	9.1	—	—	1.55	—
Fescue hay, meadow	89.2	7.0	1.9	30.3	43.2	6.8	—	0.20	1.12	1.43
Fescue hay, native western ( <i>Festuca</i> , spp.)	90.0	8.5	2.0	31.0	42.8	5.7	—	—	1.36	—
Feterita fodder, very dry	88.0	8.0	2.1	18.7	51.5	7.7	0.30	0.21	1.28	—
Feterita stover	86.3	5.2	1.7	29.2	41.9	8.3	—	—	0.83	—
Flat pea hay	92.3	22.7	3.2	27.7	32.0	6.7	—	0.30	3.63	2.02
Flax plant by product	91.9	6.4	2.1	44.4	33.1	5.9	—	—	1.02	—
Flax straw	92.8	7.2	3.2	42.5	32.9	7.0	0.48	0.07	1.15	0.73
Fowl meadow grass hay	87.4	8.7	2.3	29.7	39.5	7.2	—	—	1.39	—
Furze, dried	94.5	11.6	2.0	38.5	35.5	7.0	—	—	1.86	—
Gama grass hay ( <i>Tripsacum dactyloides</i> )	88.2	6.7	1.8	30.4	43.1	6.2	—	—	1.07	—
Grama grass hay ( <i>Bouteloua</i> , spp.)	89.8	5.8	1.6	28.9	45.6	7.9	0.34	0.18	0.93	—
Grass hay, mixed, eastern states, good quality	89.0	7.0	2.5	30.9	43.1	5.5	0.48	0.21	1.12	1.20
Grass hay, mixed, second cutting	89.0	12.3	3.3	24.8	41.7	6.9	0.79	0.31	1.97	1.15
Grass straw	85.0	4.5	2.0	35.0	37.8	5.7	—	—	0.72	—
Guar hay ( <i>Cyamopsis psoraloides</i> )	90.7	16.5	1.3	19.3	41.2	12.4	—	2.64	—	—
Hegari fodder	86.0	6.2	1.7	18.1	52.5	7.5	0.27	0.16	0.99	—
Hegari stover	87.0	5.6	1.8	28.0	41.7	9.9	0.33	0.08	0.90	—
Hops, spent, dried	93.8	23.0	3.6	24.5	37.4	5.3	—	—	3.68	—
Horse bean hay	91.5	13.4	0.8	22.0	49.8	5.5	—	—	2.14	—
Horse bean straw	87.9	8.6	1.4	36.4	33.1	8.4	—	—	1.38	—
Hyacinth bean hay ( <i>Dilichoua lablab</i> )	90.2	14.8	1.4	33.6	33.6	6.8	—	—	2.37	—
Johnson grass hay	90.1	6.5	2.1	30.4	43.7	7.4	0.87	0.26	1.04	1.22
June grass hay, western ( <i>Koeleria cristata</i> )	88.3	8.1	2.5	30.4	40.5	6.8	—	—	1.30	—
Kafir fodder, very dry	90.0	8.7	2.6	25.5	44.2	9.0	0.35	0.18	1.39	1.53
Kafir fodder, high in water	71.7	6.5	2.7	21.6	37.6	3.3	0.28	0.14	1.04	1.23
Kafir stover, very dry	90.0	5.5	1.8	29.5	44.3	8.9	0.54	0.09	0.88	—
Kafir stover, high in water	72.7	3.8	1.3	23.7	36.6	7.3	0.44	0.07	0.61	—
Koahaole forage, dried	88.7	12.7	1.9	29.8	39.2	5.1	—	—	2.03	—
<i>Kochia scoparia</i> hay	90.0	11.4	1.5	23.6	40.7	12.8	—	—	1.82	—
Kudzu hay	89.0	15.9	2.5	28.6	35.1	6.9	2.78	0.21	2.54	—
Lespedeza hay, annual, all analyses	89.2	12.7	2.4	26.7	42.2	5.2	0.98	0.18	2.03	0.91

# 500 ANALYSIS OF BASIC MATERIALS

Material	Total dry matter	Protein	Fat	Fiber	N-free extract	Total minerals	Calcium	Phosphorus	Nitrogen	Potassium
	Per ct.	Per ct.	Per ct.	Per ct.	Per ct.	Per ct.	Per ct.	Per ct.	Per ct.	Per ct.
Lespedeza hay, annual, before bloom	89.1	14.3	2.7	22.7	43.0	6.4	1.04	0.19	2.29	1.06
Lespedeza hay, annual, in bloom	89.1	13.0	1.8	26.5	42.7	5.1	1.02	0.18	2.08	0.94
Lespedeza hay, annual, after bloom	89.1	11.5	1.9	32.6	38.6	4.5	0.90	0.15	1.84	0.82
Lespedeza hay, perennial	89.0	13.2	1.7	26.5	42.7	4.9	0.92	0.22	2.11	0.98
Lespedeza leaves, annual	89.2	17.1	2.9	19.7	43.1	6.4	1.30	0.20	2.74	0.92
Lespedeza stems, annual	89.2	8.3	1.0	38.5	37.7	3.7	0.64	0.13	1.33	0.89
Lespedeza straw	90.0	6.8	2.3	29.2	47.1	4.6	—	—	1.09	—
Lovegrass hay, weeping	91.2	9.2	2.8	30.9	43.4	4.9	—	—	1.47	—
Marsh or swamp hay, good quality	90.2	7.7	2.3	28.2	44.3	7.7	—	—	1.23	—
Millet hay, foxtail varieties	87.6	8.2	2.7	25.3	44.7	6.7	0.29	0.16	1.31	1.70
Millet hay, hog millet, or proso	90.3	9.3	2.2	23.9	47.6	7.3	—	—	1.49	—
Millet hay, Japanese	86.8	8.3	1.6	27.7	40.8	8.4	0.20	—	1.33	2.10
Millet hay, pearl, or cat-tail	87.2	6.7	1.7	33.0	36.8	9.0	—	—	1.07	—
Millet straw	90.0	3.8	1.6	37.5	41.6	5.5	0.08	—	0.61	1.44
Milo fodder	88.5	8.0	3.3	21.9	48.4	6.9	0.35	0.18	1.28	—
Milo stover	91.0	3.2	1.1	29.1	48.1	9.5	0.58	0.11	0.51	—
Mint hay	88.3	12.7	2.1	20.3	45.6	7.6	1.51	0.19	2.03	—
Mixed hay, good, less than 30% legumes	88.0	8.3	1.8	30.7	41.8	5.4	0.61	0.18	1.33	1.47
Mixed hay, good, more than 30% legumes	88.0	9.2	1.9	28.1	42.8	6.0	0.90	0.19	1.47	1.46
Mixed hay, cut very early	90.0	13.3	2.7	25.3	39.4	9.3	—	—	2.13	—
Napier grass hay	89.1	8.2	1.8	34.0	34.6	10.5	—	—	1.31	—
Natal grass hay	90.2	7.4	1.8	36.8	39.2	5.0	0.45	0.29	1.18	—
Native hay, western mt. states, good quality	90.0	8.1	2.1	29.8	43.2	6.8	0.39	0.12	1.30	—
Native hay, western mt. states, mature and weathered	90.0	3.9	1.4	33.6	43.6	7.5	—	—	0.62	—
Needle grass hay ( <i>Stipa</i> , spp.)	88.1	7.2	2.0	30.8	41.9	6.2	—	—	1.15	—
Oak leaves, live oak, dried	93.8	9.3	2.7	29.9	45.3	6.6	—	—	1.49	—
Oat chaff	91.8	5.9	2.4	25.7	46.3	11.5	0.80	0.30	0.94	0.86
Oat hay	88.1	8.2	2.7	28.1	42.2	6.9	0.21	0.19	1.31	0.83
Oat hay, wild ( <i>Avena fatua</i> )	92.5	6.6	2.6	32.5	44.0	6.8	0.22	0.25	1.06	—
Oat hulls	92.8	4.5	1.3	29.7	50.8	6.5	0.20	0.10	0.78	0.48
Oat straw	89.7	4.1	2.2	36.1	41.0	6.3	0.19	0.10	0.66	1.35
Oat grass hay, tall	88.7	7.5	2.4	30.1	42.7	6.0	—	0.14	1.20	1.36
Orchard grass hay, early-cut	88.6	7.7	2.9	30.5	40.7	6.8	0.19	0.17	1.23	1.61
Picnic grass hay ( <i>Panicum</i> , spp.)	92.1	8.3	2.3	29.5	44.9	7.1	—	—	1.33	—
Para grass hay	90.2	4.6	0.9	33.6	44.5	6.6	0.35	0.35	0.74	1.44
Pasture grasses and clovers, mixed, from closely grazed, fertile pasture, dried (northern states)	90.0	20.3	3.6	19.7	38.7	7.7	0.58	0.32	3.25	2.18
Pasture grasses, mixed, from poor to fair pasture, before heading out, dried	90.0	14.1	2.3	19.4	43.2	11.0	0.41	0.12	2.26	0.74
Pasture grass, western plains, growing, dried	90.0	11.6	2.5	28.0	40.2	7.7	0.37	0.24	1.86	—
Pasture grass, western plains, mature, dried	90.0	4.6	2.3	31.9	45.3	5.9	0.34	0.14	0.74	—
Pasture grass, western plains, mature and weathered	90.0	3.3	1.8	34.1	44.5	6.3	0.33	0.09	0.53	—

ANALYSIS OF BASIC MATERIALS 501

Material	Total dry	Protein	Fat	Fiber	N-free	Total	Calcium	Phos-	Nitro-	Potas-
	matter				extract	minerals		phorus	gen	sium
	Per ct.	Per ct.	Per ct.	Per ct.	Per ct.	Per ct.	Per ct.	Per ct.	Per ct.	Per ct.
Pasture grass and other forage on western mt. ranges, spring, dried	90.0	17.0	3.1	14.0	49.1	6.8	1.21	0.38	2.72	—
Pasture grass and other forage on western mt. ranges, autumn, dried	90.0	8.8	4.3	17.4	51.4	8.1	—	—	1.41	—
Pea hay, field	89.3	14.9	3.3	24.3	39.1	7.7	1.22	0.25	2.38	1.25
Pea straw, field	90.2	6.1	1.6	33.1	44.0	5.4	—	0.10	0.98	1.08
Pea-and-oat hay	89.1	12.1	2.9	27.2	39.1	7.8	0.72	0.22	1.94	1.04
Peanut hay, without nuts	90.7	10.1	3.3	23.4	44.2	9.7	1.12	0.13	1.62	1.25
Peanut hay, with nuts	92.0	13.4	12.6	23.0	34.9	8.1	1.13	0.15	2.14	0.85
Peanut hay, mowed	91.4	10.6	5.1	23.8	42.2	9.7	—	—	1.70	—
Peanut hulls, with a few nuts	92.3	6.7	1.2	60.3	19.7	4.4	0.30	0.07	1.07	0.82
Peavine hay, from pea-cannery vines, sun-cured	86.3	11.9	2.4	23.0	42.2	6.8	1.48	0.16	1.90	—
Prairie hay, western, good quality	90.7	.57	2.3	30.4	44.9	7.4	0.36	0.18	0.91	—
Prairie hay, western, mature	91.7	3.8	2.4	31.9	47.1	6.5	0.28	0.09	0.61	0.49
Quack grass hay	89.0	6.9	1.9	34.5	38.8	6.9	—	—	1.10	—
Ramie meal	92.2	19.2	3.8	20.1	35.9	13.2	4.32	0.22	3.07	—
Red top hay	91.0	7.2	2.3	29.3	45.3	6.9	0.33	0.23	1.15	1.93
Reed canary grass hay	91.1	7.7	2.3	29.2	44.3	7.6	0.33	0.16	1.23	—
Rescue grass hay	90.2	9.8	3.2	24.6	44.5	8.1	—	—	1.57	—
Rhodes grass hay	89.0	5.7	1.3	31.7	41.8	8.5	0.35	0.27	0.91	1.18
Rice hulls	92.0	3.0	0.8	40.7	28.4	19.1	0.08	0.08	0.48	0.31
Rice straw	92.5	3.9	1.4	33.5	39.2	14.5	0.19	0.07	0.62	1.22
Rush hay, western ( <i>Juncus</i> , spp.)	90.0	9.4	1.8	29.2	44.2	5.4	—	—	1.50	—
Russian thistle hay	87.5	8.9	1.6	26.9	37.4	12.7	—	—	1.42	—
Rye grass hay, Italian	88.6	8.1	1.9	27.8	43.3	7.5	—	0.24	1.30	1.00
Rye grass hay, perennial	88.0	9.2	3.1	24.2	43.4	8.1	—	0.24	1.47	1.25
Rye grass hay, native western	87.4	7.8	2.1	33.5	37.6	6.4	—	—	1.25	—
Rye hay	91.3	6.7	2.1	36.5	41.0	5.0	—	0.18	1.07	1.05
Rye straw	92.8	3.5	1.2	38.7	45.9	3.5	0.26	0.09	0.56	0.90
Salt bushes, dried	93.5	13.8	1.6	22.1	38.8	17.2	1.88	0.11	2.21	4.69
Salt grass hay, misc. var.	90.0	8.1	1.8	28.8	39.5	11.8	—	—	1.30	—
Sanfoin hay ( <i>Onobrychis viciaefolia</i> )	84.1	10.5	2.6	19.7	44.2	7.1	—	—	1.68	—
Seaweed, dried ( <i>Fucus</i> , spp.)	88.7	5.2	4.2	9.4	53.6	16.3	—	—	0.83	—
Seaweed, dried ( <i>Laminaria</i> , spp.)	83.7	11.4	1.1	8.6	45.8	16.8	—	—	1.82	—
Sedge hay, eastern ( <i>Carex</i> , spp.)	90.7	6.1	1.7	29.2	46.3	7.4	—	—	0.98	—
Sedge hay, western ( <i>Carex</i> , spp.)	90.6	10.1	2.4	27.3	44.0	6.8	0.60	0.24	1.62	—
Seradella hay	89.0	16.4	3.2	29.8	32.0	7.6	—	0.33	2.62	1.25
Sorghum bagasse, dried	89.3	3.1	1.4	31.3	50.0	3.5	—	—	0.50	—
Sorghum fodder, sweet, dry	88.8	6.2	2.4	25.0	48.1	7.1	0.34	0.12	0.99	1.29
Sorghum fodder, sweet, high in water	65.7	4.5	2.4	16.6	37.6	4.6	0.25	0.09	0.72	0.96
Soybean hay, good, all analyses	88.0	14.4	3.3	27.5	35.8	7.0	0.94	0.24	2.30	0.82
Soybean hay, in bloom or before	88.0	16.7	3.3	20.6	37.8	9.6	1.53	0.27	2.67	0.86
Soybean hay, seed developing	88.0	14.6	2.4	27.2	36.5	7.3	1.35	0.25	2.34	0.78
Soybean hay, seed nearly ripe	88.0	15.2	6.6	24.0	38.2	4.0	0.86	0.32	2.43	0.81
Soybean hay, poor quality, weathered	89.0	9.2	1.2	41.0	30.4	7.2	0.94	—	1.47	—

# 502 ANALYSIS OF BASIC MATERIALS

Material	Total dry matter	Protein	Fat	Fiber	N-free extract	Total minerals	Calcium	Phosphorus	Nitrogen	Potassium
	Per ct.	Per ct.	Per ct.	Per ct.	Per ct.	Per ct.	Per ct.	Per ct.	Per ct.	Per ct.
Soybean straw	88.8	4.0	1.1	41.1	37.5	5.1	—	0.13	0.64	0.62
Soybean and Sudan grass hay, chiefly Sudan	89.0	7.4	2.2	31.1	43.4	4.9	—	—	1.18	—
Spanish moss, dried	89.2	5.0	2.4	26.6	47.7	7.5	—	0.04	0.80	0.46
Sudan grass hay, all analyses	89.3	8.8	1.6	27.9	42.9	8.1	0.36	0.26	1.41	1.30
Sudan grass hay, before bloom	89.6	11.2	1.5	26.1	41.3	9.5	0.41	0.26	1.79	—
Sudan grass hay, in bloom	89.2	8.4	1.5	30.7	41.8	6.8	—	—	1.34	—
Sudan grass hay, in seed	89.5	6.8	1.6	29.9	44.4	6.8	0.27	0.19	1.09	—
Sudan grass, young, dehydrated	88.0	14.5	2.5	20.4	41.2	9.4	0.52	0.39	2.32	—
Sudan grass straw	90.4	7.1	1.5	33.0	42.3	6.5	—	—	1.14	—
Sugar cane fodder, Japanese, dried	89.0	1.3	1.8	19.7	64.3	1.9	0.32	0.14	0.21	0.58
Sugar cane bagasse, dried	95.5	1.1	0.4	49.6	42.0	2.4	—	—	0.18	—
Sugar cane pulp, dried	93.8	1.7	0.6	45.6	42.2	3.7	—	—	0.27	—
Sweet potato vine, dried	90.7	12.6	3.3	19.1	45.5	10.2	—	—	2.02	—
Teosinte fodder, dried	89.4	9.1	1.9	26.5	41.7	10.3	—	0.17	1.46	0.88
Timothy hay, all analyses	89.0	6.5	2.4	30.2	45.0	4.9	0.23	0.20	1.04	1.50
Timothy hay, before bloom	89.0	9.7	2.7	27.4	42.7	6.5	—	—	1.55	—
Timothy, full bloom	89.0	6.4	2.5	30.4	44.8	4.9	0.23	0.20	1.02	1.50
Timothy hay, in bloom, nitrogen fertilized	89.0	9.7	2.1	31.6	42.6	3.9	0.40	0.21	1.41	1.41
Timothy hay, late seed	89.0	5.3	2.3	31.0	45.9	4.5	0.14	0.15	0.85	1.41
Timothy hay, in bloom, dehydrated	89.0	7.7	2.3	28.3	45.5	5.2	—	—	1.23	—
Timothy hay, second cutting	88.7	15.0	4.6	25.4	36.5	7.2	—	—	2.40	—
Timothy and clover hay, one-fourth clover	88.8	7.8	2.4	29.5	43.8	5.3	0.51	0.20	1.25	1.48
Velvet bean hay	92.8	16.4	3.1	27.5	38.4	7.4	—	0.24	2.62	2.20
Vetch hay, common	89.0	13.3	1.1	25.2	32.2	6.2	1.18	0.32	2.13	2.22
Vetch hay, hairy	88.0	19.3	2.6	24.5	33.1	8.5	1.13	0.32	3.09	1.96
Vetch-and-oat hay, over half vetch	87.6	11.9	2.7	27.3	37.5	8.2	0.76	0.27	1.90	1.51
Vetch-and-wheat hay, cut early	90.0	15.4	2.2	28.8	36.4	7.2	—	—	2.46	—
Wheat chaff	90.0	4.4	1.5	29.4	47.1	7.6	0.21	0.14	0.70	0.50
Wheat hay	90.4	6.1	1.8	26.1	50.0	6.4	0.14	0.18	0.98	1.47
Wheat straw	92.5	3.9	1.5	36.9	41.9	8.3	0.21	0.07	0.62	0.79
Wheat grass hay, crested, cut early	90.0	9.2	2.0	32.2	40.2	6.4	—	—	1.47	—
Wheat grass hay, slender	90.0	8.0	2.1	32.2	41.0	6.7	0.30	0.24	1.28	2.41
Winter fat, or white sage, dried ( <i>Eurotia lanata</i> )	92.6	12.9	1.9	27.4	40.8	9.6	—	—	2.06	—
Wire grass hay, southern ( <i>Aristida</i> , spp.)	90.0	5.5	1.4	31.8	47.9	3.4	0.15	0.14	0.88	—
Wire grass hay, western ( <i>Aristida</i> , spp.)	90.0	6.4	1.3	34.1	41.0	7.2	—	—	1.02	—
Yucca, or beargrass, dried	92.6	6.6	2.2	38.6	38.3	6.9	—	—	1.06	—

## CONCENTRATES

Material	Total dry matter	Protein	Fat	Fiber	N-free extract	Total minerals	Calcium	Phosphorus	Nitrogen	Potassium
	Per ct.	Per ct.	Per ct.	Per ct.	Per ct.	Per ct.	Per ct.	Per ct.	Per ct.	Per ct.
Acorns, whole (red oak)	50.0	3.2	10.7	9.9	25.0	1.2	—	—	0.51	—
Acorns, whole (white and post oaks)	50.0	2.7	3.0	9.3	33.7	1.3	—	—	0.43	—
Alfalfa-molasses feed	86.0	11.4	1.2	18.5	46.2	8.7	—	—	1.82	—
Alfalfa seed	88.3	33.2	10.6	8.1	32.0	4.4	—	—	5.31	—

Material	Total dry	Protein	Fat	Fiber	N-free	Total	Calcium	Phos-	Nitro-	Potas-
	matter	Per ct.	Per ct.	Per ct.	extract	minerals	Per ct.	phorus	gen	sium
	Per ct.	Per ct.	Per ct.	Per ct.	Per ct.	Per ct.	Per ct.	Per ct.	Per ct.	Per ct.
Alfalfa seed screenings	90.3	31.1	9.9	11.1	33.1	5.1	—	—	4.98	—
Apple-pectin pulp, dried	91.2	7.0	7.3	24.2	49.4	3.3	—	—	1.12	—
Apple-pectin pulp, wet	16.7	1.5	0.9	5.8	7.9	0.6	—	—	0.24	—
Apple pomace, dried	89.4	4.5	5.0	15.6	62.1	2.2	0.10	0.09	0.72	0.43
Apple pomace, wet	21.1	1.3	1.3	3.7	13.9	0.9	0.02	0.02	0.21	0.10
Atlas sorghum grain	89.1	11.3	3.3	2.0	70.6	1.9	—	—	1.81	—
Atlas sorghum head chops	88.0	9.5	2.8	10.7	60.2	4.8	—	—	1.52	—
Avocado oil meal	91.4	18.6	1.1	17.6	36.0	18.1	—	—	2.98	—
Babassu oil meal	92.8	24.2	6.8	12.0	44.6	5.2	0.13	0.71	3.87	—
Bakery waste, dried (high in fat)	91.6	10.9	13.7	0.7	64.7	1.6	—	—	1.74	—
Barley, common, not including Pacific Coast states	89.4	12.7	1.9	5.4	66.6	2.8	0.06	0.37	2.03	0.49
Barley, Pacific Coast states	89.8	8.7	1.9	5.7	70.9	2.6	—	—	1.39	—
Barley, light weight	89.1	12.1	2.1	7.4	64.3	3.2	—	—	1.94	—
Barley, hull-less, or bald	90.2	11.6	2.0	2.4	72.1	2.1	—	—	1.86	—
Barley feed, high grade	90.3	13.5	3.5	8.7	60.5	4.1	0.03	0.40	2.16	0.60
Barley feed, low grade	92.0	12.3	3.45	14.7	56.2	5.3	—	—	1.97	—
Barley, malted	93.4	12.7	2.1	5.4	70.9	2.3	0.06	0.42	2.03	0.37
Barley screenings	88.6	11.6	2.7	9.1	61.3	3.9	—	—	1.86	—
Beans, field, or navy	90.0	22.9	1.4	4.2	57.3	4.2	0.15	0.57	3.66	1.27
Beans, kidney	89.0	23.0	1.2	4.1	56.8	3.9	—	—	3.68	—
Beans, lima	89.7	21.2	1.1	4.7	58.2	4.5	0.09	0.37	3.39	1.70
Beans, mung	90.2	23.3	1.0	3.5	58.5	3.9	—	—	3.73	—
Beans, pinto	89.9	22.5	1.2	4.1	57.7	4.4	—	—	3.60	—
Beans, tepary	90.5	22.2	1.4	3.4	59.3	4.2	—	—	3.56	—
Beechnuts	91.4	15.0	30.6	15.0	27.5	3.3	0.58	0.30	2.40	0.62
Beef scraps	94.5	55.6	10.9	1.2	0.5	26.3	—	—	8.90	—
Beet pulp, dried	90.1	9.2	0.5	19.8	57.2	3.4	0.67	0.08	1.47	0.18
Beet pulp, molasses, dried	91.9	10.7	0.7	16.0	59.4	5.1	0.62	0.09	1.71	1.63
Beet pulp, wet	11.6	1.5	0.3	4.0	5.3	0.5	0.09	0.01	0.24	0.02
Beet pulp, wet, pressed	14.2	1.4	0.4	4.6	7.1	0.7	—	—	0.22	—
Blood flour, or soluble blood meal	92.2	84.7	1.0	1.1	0.7	4.7	0.68	0.50	13.55	—
Blood meal	91.8	84.5	1.1	1.0	0.7	4.5	0.33	0.25	13.52	0.09
Bone meal, raw	93.6	26.0	5.0	1.0	2.5	59.1	23.05	10.22	4.16	—
Bone meal, raw, solvent process	93.1	25.7	1.0	1.0	1.9	63.5	24.02	10.65	4.11	—
Bone meal, steamed	96.3	7.1	3.3	0.8	3.8	81.3	31.74	15.00	1.14	0.18
Bone meal, steamed, solvent process	96.8	7.2	0.4	1.5	3.7	84.0	—	—	1.15	—
Bone meal, steamed, special	97.7	13.5	7.9	1.0	5.1	70.2	31.88	13.48	2.16	—
Bone meal, 10 to 20% protein	97.2	14.6	6.5	1.5	3.6	71.0	26.00	12.66	2.34	—
Bread, white, enriched	64.1	8.5	2.0	0.3	52.0	1.3	0.06	0.10	1.36	0.10
Brewers' grains, dried, 25% protein or over	92.9	27.6	6.5	14.3	40.9	3.6	0.29	0.48	4.42	0.10
Brewers' grains, dried, below 25% protein	92.3	23.4	6.4	16.1	42.5	3.9	—	—	3.74	—
Brewers' grains, dried, from California barley	91.1	20.0	5.7	18.1	43.6	3.7	—	—	3.20	—
Brewers' grains, wet	23.7	5.7	1.6	3.6	11.8	1.0	0.07	0.12	0.91	0.02
Broom corn seed	89.7	9.2	3.7	5.1	69.1	2.6	—	—	1.47	—
Buckwheat, ordinary varieties	88.0	10.3	2.3	10.7	62.8	1.9	0.09	0.31	1.64	0.45

# 504 ANALYSIS OF BASIC MATERIALS

Material	Total dry matter	Protein	Fat	Fiber	N-free extract	Total minerals	Calcium	Phosphorus	Nitrogen	Potassium
	Per ct.	Per ct.	Per ct.	Per ct.	Per ct.	Per ct.	Per ct.	Per ct.	Per ct.	Per ct.
Buckwheat, Tartary	88.1	10.1	2.4	12.7	60.9	2.0	0.13	0.31	1.62	0.44
Buckwheat feed, good grade	89.3	18.5	4.9	18.2	43.5	4.2	—	0.48	2.96	0.66
Buckwheat feed, low grade	88.3	13.3	3.4	28.6	39.8	3.2	—	0.37	2.13	0.68
Buckwheat flour	88.1	10.2	2.1	0.9	73.4	1.5	0.01	0.09	1.63	0.16
Buckwheat kernels, without hulls	88.0	14.1	3.4	1.8	66.5	2.2	0.05	0.45	2.26	0.49
Buckwheat middlings	88.7	29.7	7.3	7.4	39.4	4.9	—	1.02	4.76	0.98
Buttermilk	9.4	3.5	0.6	0	4.5	0.8	0.14	0.08	0.56	0.07
Buttermilk, condensed	29.7	10.9	2.2	0	12.6	4.0	0.44	0.26	1.74	0.23
Buttermilk, dried	92.4	32.4	6.4	0.3	43.3	10.0	1.36	0.82	5.18	0.71
Carob bean and pods	87.8	5.5	2.6	8.7	68.5	2.5	—	—	0.88	—
Carob bean pods	89.5	4.7	2.5	8.7	70.9	2.7	—	—	0.75	—
Carob bean seeds	88.5	16.7	2.6	7.6	58.4	3.2	—	—	2.67	—
Cassava roots, dried	94.4	2.8	0.5	5.0	84.1	2.0	—	—	0.45	—
Cassava meal (starch waste)	86.8	0.9	0.7	4.6	78.8	1.8	—	0.03	0.14	0.23
Cheese rind, or cheese meal	91.0	59.5	8.9	0.4	10.7	11.5	—	—	9.52	—
Chess, or cheat, seed	89.6	9.7	1.7	8.2	66.4	3.6	—	—	1.56	—
Chick peas	90.0	20.3	4.3	8.5	54.0	2.9	—	—	3.24	—
Citrus pulp, dried	90.1	5.9	3.1	11.5	62.7	6.9	2.07	0.15	0.94	—
Citrus pulp and molasses, dried	92.0	5.3	2.8	9.3	66.6	8.0	—	—	0.84	—
Citrus pulp, wet	18.3	1.2	0.6	2.3	12.8	1.4	—	—	0.19	—
Clover seed, red	87.5	32.6	7.8	9.2	31.2	6.7	—	—	5.22	—
Clover seed screenings, red	90.5	28.2	5.9	10.2	40.3	5.9	—	—	4.51	—
Clover seed screenings, sweet	90.1	21.7	3.7	14.7	41.1	8.9	—	—	3.47	—
Cocoa meal	96.0	24.3	17.1	5.1	43.7	5.8	—	—	3.89	—
Cocoa shells	95.1	15.4	3.0	16.5	49.9	10.3	—	0.59	2.46	2.16
Coconut oil meal, hydr. or exp. process	93.2	21.3	6.7	10.7	48.3	6.2	0.21	0.64	3.41	1.95
Coconut oil meal, high in fat	93.7	21.0	10.6	11.3	44.4	6.4	—	—	3.36	—
Coconut oil meal, solvent process	91.1	21.4	2.4	13.3	47.4	6.6	—	—	3.42	—
Cod-liver oil meal	92.5	50.4	28.9	0.7	9.6	2.9	0.18	0.61	8.06	—
Corn, dent, Grade No. 1	87.0	8.8	4.0	2.1	70.9	1.2	0.02	0.28	1.41	0.28
Corn, dent, Grade No. 2	85.0	8.6	3.9	2.0	69.3	1.2	0.02	0.27	1.38	0.27
Corn, dent, Grade No. 3	83.5	8.4	3.8	2.0	68.1	1.2	0.02	0.27	1.34	0.27
Corn, dent, Grade No. 4	81.1	8.2	3.7	1.9	66.2	1.1	0.02	0.26	1.31	0.26
Corn, dent, Grade No. 5	78.5	7.9	3.6	1.9	64.0	1.1	0.02	0.25	1.26	0.25
Corn, dent, soft or immature	70.0	7.2	2.3	2.5	56.5	1.5	—	0.24	1.16	0.26
Corn, flint	88.5	9.8	4.3	1.9	71.0	1.5	—	0.33	1.57	0.32
Corn, pop	90.0	11.5	5.0	1.9	70.1	1.5	—	0.29	1.84	—
Corn ears, including kernels and cobs (corn-and-cob meal)	86.1	7.3	3.2	8.0	66.3	1.3	—	0.22	1.17	0.29
Corn ears, soft or immature	64.3	5.8	1.9	7.8	47.7	1.1	—	—	0.93	—
Corn, snapped, or ear-corn chops with husks	88.8	8.0	3.0	10.6	64.8	2.4	—	—	1.28	—
Corn, snapped, very soft or immature	60.0	5.3	1.8	8.2	42.7	2.0	—	—	0.85	—
Corn bran	90.6	9.7	7.3	9.2	62.0	2.4	0.03	0.27	1.56	0.56
Corn feed meal	88.6	9.8	4.7	2.9	69.2	2.0	0.03	0.34	1.57	0.28
Corn germ meal	93.0	19.8	7.8	8.9	53.2	3.3	—	0.58	3.17	0.21
Corn gluten feed, all analyses	90.9	25.5	2.7	7.6	48.8	6.3	0.48	0.82	4.08	0.54



ANALYSIS OF BASIC MATERIALS 505

Material	Total dry matter	Protein	Fat	Fiber	N-free extract	Total minerals	Calcium	Phosphorus	Nitrogen	Potassium
	Per ct.	Per ct.	Per ct.	Per ct.	Per ct.	Per ct.	Per ct.	Per ct.	Per ct.	Per ct.
Corn gluten feed, 25% protein guarantee	91.1	26.6	3.0	7.2	48.2	6.1	—	—	4.26	—
Corn gluten feed, 23% protein guarantee	91.4	24.8	2.6	7.8	49.8	6.4	—	—	3.97	—
Corn gluten feed with molasses	88.8	22.6	2.1	6.8	50.9	6.4	—	—	3.62	—
Corn gluten meal, all analyses	91.4	43.1	2.0	4.0	39.8	2.5	0.13	0.38	6.90	0.02
Corn gluten meal, 41% protein guarantee	91.4	42.9	2.0	3.9	40.1	2.5	—	—	6.86	—
Corn grits	88.4	8.5	0.5	0.6	78.4	0.4	—	—	1.36	—
Corn meal, degerminated, yellow	88.7	8.7	1.2	0.6	77.1	1.1	0.01	0.14	1.39	—
Corn meal, degerminated, white	88.4	8.6	1.2	0.7	76.1	1.8	0.01	0.14	1.38	—
Corn oil meal, old process	91.7	22.3	7.8	10.3	49.0	2.3	0.06	0.56	3.57	—
Corn oil meal, solvent process	91.7	23.0	1.5	10.4	54.6	2.2	0.03	0.50	3.68	—
Corn-starch	88.6	11.6	0.6	0.1	0.2	87.6	0.1	—	—	0.10
Corn-and-oat feed, good grade	89.6	11.9	4.0	5.4	65.9	2.4	0.05	0.30	1.90	0.34
Corn-and-oat feed, low grade	89.6	9.1	2.9	13.4	59.0	5.2	—	—	1.46	—
Cottonseed, whole	92.7	23.1	22.9	16.9	26.3	3.5	0.14	0.70	3.70	1.11
Cottonseed, immature, dried	93.2	20.5	15.9	24.1	29.0	3.7	—	—	3.28	—
Cottonseed, whole pressed, 28% protein guarantee	93.5	28.2	5.8	22.6	32.2	4.7	—	—	4.51	—
Cottonseed, whole pressed, below 28% protein	93.5	26.9	6.5	24.7	30.8	4.6	0.17	0.64	4.30	1.25
Cottonseed feed, below 36% protein	92.4	34.6	6.3	14.1	31.5	5.9	0.26	0.83	5.54	1.22
Cottonseed flour	94.4	57.0	7.2	2.1	21.6	6.5	—	—	9.12	—
Cottonseed kernels, without hulls	93.6	38.4	33.3	2.3	15.1	4.5	—	—	6.14	—
Cottonseed meal, 45% protein and over	93.5	46.2	7.7	8.6	24.9	6.1	0.22	1.13	7.39	—
Cottonseed meal, 43% protein grade, not including Texas analyses	92.7	43.9	7.1	9.0	26.3	6.4	0.23	1.12	7.02	1.45
Cottonseed meal, 43% protein grade, Texas analyses	92.5	42.7	6.4	10.6	27.0	5.8	0.19	0.96	6.83	1.34
Cottonseed meal, 41% protein grade, not including Texas analyses	92.8	41.5	6.3	10.4	28.1	6.5	0.20	1.22	6.64	1.48
Cottonseed meal, 41% protein grade, Texas analyses	92.1	41.0	6.0	11.6	27.6	5.9	—	—	6.56	—
Cottonseed meal, below 41% protein grade	92.4	38.2	6.2	12.3	29.4	6.3	0.23	1.29	6.11	1.57
Cottonseed meal, solvent process	90.8	44.4	2.6	12.7	24.3	6.8	—	—	7.10	—
Cowpea seed	89.0	23.4	1.4	4.0	56.7	3.5	0.11	0.46	3.74	1.30
Crab meal	92.4	31.5	2.0	10.7	5.0	43.2	15.15	1.63	5.04	0.45
Darso grain	90.0	10.1	3.1	1.9	73.5	1.4	0.02	0.32	1.62	—
Distillers' dried corn grains, without solubles	92.9	28.3	8.8	11.4	41.9	2.5	0.11	0.47	4.53	0.24
Distillers' dried corn grains, with solubles	93.1	28.8	8.9	9.0	41.7	4.7	0.16	0.74	4.61	—
Distillers' dried corn grains, solvent extracted	93.7	33.4	1.4	8.6	46.4	3.9	—	—	5.34	—
Distillers' dried rye grains	93.9	18.5	6.4	15.6	51.0	2.4	0.13	0.43	2.96	0.04
Distillers' rye grains, wet	22.4	4.4	1.5	2.5	13.3	0.7	—	—	0.70	—
Distillers' dried wheat grains	93.7	28.7	6.1	13.0	42.2	3.7	—	—	4.59	—
Distillers' dried wheat grains, high protein	94.7	46.2	5.7	10.9	30.0	1.9	—	—	7.39	—
Distillers' solubles, dried, corn	93.0	26.7	7.9	2.6	48.4	7.4	0.30	1.41	4.27	1.75
Distillers' solubles, dried, wheat	94.0	28.2	1.5	2.8	58.9	2.6	—	—	4.51	—
Distillery stillage, corn, whole	7.9	2.3	0.6	0.7	4.0	0.3	0.006	0.05	0.37	—
Distillery stillage, rye, whole	5.9	1.9	0.3	0.5	2.9	0.3	—	—	0.30	—

# 506 ANALYSIS OF BASIC MATERIALS

Material	Total dry matter Per ct.	Protein Per ct.	Fat Per ct.	Fiber Per ct.	N-free extract Per ct.	Total minerals Per ct.	Calcium Per ct.	Phos- phorus Per ct.	Nitro- gen Per ct.	Potas- sium Per ct.
Distillery stillage, strained	3.8	1.1	0.4	0.2	1.8	0.3	0.004	0.05	0.18	—
Durra grain	89.8	10.3	3.5	1.6	72.4	2.0	—	—	1.64	—
Emmer grain	91.1	12.1	1.9	9.8	63.6	3.7	—	0.33	1.94	0.47
Feterita grain	89.4	12.2	3.2	2.2	70.1	1.7	0.02	0.33	1.96	—
Feterita head chops	89.6	10.7	2.6	7.4	65.7	3.2	—	—	1.71	—
Fish-liver oil meal	92.8	62.8	17.3	1.2	5.4	6.1	—	—	10.04	—
Fish meal, all analyses	92.9	63.9	6.8	0.6	4.0	17.6	4.14	2.67	10.22	0.40
Fish meal, over 63% protein	92.7	66.8	5.3	0.5	4.5	15.6	—	—	10.69	—
Fish meal, 58-63% protein	93.1	60.9	8.1	0.8	3.5	19.8	—	—	9.74	—
Fish meal, below 58% protein	93.2	56.2	11.0	0.7	2.9	22.4	—	—	8.99	—
Fish meal, herring	93.5	72.5	7.3	0.7	1.5	11.5	2.97	2.08	11.60	—
Fish meal, menhaden	93.6	62.2	8.5	0.7	4.2	18.0	5.30	3.38	9.96	—
Fish meal, redfish	94.2	56.7	11.4	0.9	0.9	24.3	4.01	2.44	9.07	—
Fish meal, salmon	92.8	59.4	9.8	0.3	4.3	19.0	5.49	3.65	9.50	—
Fish meal, sardine	93.1	67.2	5.0	0.6	5.4	14.9	4.21	2.54	10.76	0.33
Fish meal, tuna	90.1	58.2	7.9	0.7	3.4	19.9	4.80	3.10	9.31	—
Fish meal, whitefish	90.4	63.0	6.7	0.1	0.1	20.5	—	—	10.08	—
Fish solubles, condensed	49.5	29.3	8.4	—	2.2	9.6	—	—	4.69	—
Flaxseed	93.8	24.0	35.9	6.3	24.0	3.6	0.26	0.55	3.84	0.59
Flaxseed screenings	91.1	16.4	9.4	12.7	45.8	6.8	0.37	0.43	2.62	—
Flaxseed screenings oil feed	91.9	25.0	7.1	11.7	40.3	7.8	—	—	4.00	—
Garbage	39.3	6.0	7.2	1.1	22.2	2.8	—	—	0.96	—
Garbage, processed, high in fat	95.9	17.5	23.7	20.0	21.8	12.9	—	0.33	2.80	0.62
Garbage, processed, low in fat	92.3	23.1	3.5	13.5	38.1	14.1	—	—	3.70	—
Grapefruit pulp, dried	91.7	4.9	1.1	11.9	69.6	4.2	—	—	0.78	—
Grape pomace, dried	91.0	12.2	6.9	30.2	36.7	5.0	—	—	1.96	—
Hegari grain	89.7	9.6	2.6	2.0	73.9	1.6	0.18	0.30	1.54	—
Hegari head chops	89.6	10.0	2.1	11.9	60.6	5.0	—	—	1.60	—
Hempseed oil meal	92.0	31.0	6.2	23.8	22.0	9.0	0.25	0.43	4.96	—
Hominy feed, 5% fat or more	90.4	11.2	6.9	5.2	64.2	2.9	0.22	0.71	1.79	0.61
Hominy feed, low in fat	89.7	10.6	4.3	5.0	67.4	2.4	—	—	1.70	—
Horse beans	87.5	25.7	1.4	8.2	48.8	3.4	0.13	0.54	4.11	1.16
Ivory nut meal, vegetable	89.4	4.7	0.9	7.2	75.5	1.1	—	—	0.76	—
Jack beans	89.3	24.7	3.2	8.2	50.4	2.8	—	—	3.96	—
Kafir grain	89.8	10.9	2.9	1.7	72.7	1.6	0.02	0.31	1.74	0.34
Kafir head chops	89.2	10.0	2.6	6.9	66.4	3.3	0.08	0.27	1.60	—
Kalo sorghum grain	89.2	11.8	3.2	1.6	70.9	1.7	—	—	1.89	—
Kaoliang grain	89.9	10.5	4.1	1.6	71.8	1.9	—	—	1.68	—
Kelp, dried	91.3	6.5	0.5	6.5	42.6	35.2	2.48	0.28	1.04	—
Lamb's-quarters seed	90.0	20.6	4.5	15.1	40.2	9.6	—	—	3.30	—
Lespedeza seed, annual	91.7	36.6	7.6	9.6	32.8	5.1	—	—	5.86	—
Lespedeza seed, sericea	92.3	33.5	4.2	13.5	37.3	3.8	—	—	5.36	—
Lemon pulp, dried	92.8	6.4	1.2	15.0	65.2	5.0	—	—	1.02	—
Linseed meal, old process, all analyses	91.0	35.4	5.8	8.2	36.0	5.6	0.39	0.87	5.66	1.24
Linseed meal, o.p., 37% protein or more	90.9	38.0	5.9	7.7	33.7	5.6	0.39	0.86	6.08	1.10
Linseed meal, o.p., 33-37% protein	91.0	35.0	5.7	8.3	36.4	5.6	0.41	0.86	5.60	1.14

ANALYSIS OF BASIC MATERIALS 507

Material	Total dry matter Per ct.	Protein Per ct.	Fat Per ct.	Fiber Per ct.	N-free extract Per ct.	Total minerals Per ct.	Calcium Per ct.	Phos- phorus Per ct.	Nitro- gen Per ct.	Potas- sium Per ct.
Linseed meal, o.p., 31-33% protein	91.0	32.4	5.9	8.3	38.7	5.7	0.36	0.90	5.18	1.40
Linseed meal, solvent process, older analyses	90.4	36.9	2.9	8.7	36.3	5.6	—	—	5.90	—
Linseed meal and screenings oil feed (linseed feed)	90.5	31.2	5.4	10.1	37.0	6.8	0.43	0.65	4.99	—
Liver meal, animal	92.3	66.2	16.4	1.4	1.9	6.4	0.62	1.27	10.59	—
Locust beans and pods, honey	88.4	9.3	2.4	16.1	57.1	3.5	—	—	1.49	—
Lupine seed, sweet, yellow	88.9	39.8	4.9	14.0	25.7	4.5	0.23	0.39	6.37	0.81
Malt, barley	90.6	14.3	1.6	1.8	70.6	2.3	0.08	0.47	2.29	—
Malt sprouts	92.6	26.8	1.3	14.2	44.3	6.0	—	—	4.29	—
Meat scraps, or dry-rendered tankage, 60% protein grade	93.8	60.9	8.8	2.4	1.1	20.6	6.09	3.49	9.74	—
Meat scraps, or dry-rendered tankage, 55% protein grade	93.9	55.8	9.3	2.1	1.3	25.4	8.33	4.04	8.93	—
Meat scraps, or dry-rendered tankage, 55% protein grade, low fat	93.0	56.0	3.5	2.6	1.5	29.4	—	—	8.96	—
Meat scraps, or dry-rendered tankage, 52% protein grade	93.1	52.9	7.3	2.2	4.3	26.4	—	—	8.46	—
Meat and bone scraps, or dry-rendered tankage with bone, 50% protein grade	93.9	51.0	10.1	2.1	1.6	29.1	9.71	4.81	8.16	—
Meat and bone scraps, or dry-rendered tankage with bone, 45% protein grade	94.5	46.3	12.0	2.0	2.3	31.9	11.21	4.88	7.41	—
Mesquite beans and pods	94.0	13.0	2.8	26.3	47.4	4.5	—	—	2.08	—
Milk, cow's	12.8	3.5	3.7	0	4.9	0.7	0.12	0.09	0.56	0.14
Milk, ewe's	19.2	6.5	6.9	0	4.9	0.9	0.21	0.12	1.04	0.19
Milk, goat's	12.8	3.7	4.1	0	4.2	0.8	0.13	0.10	0.59	0.15
Milk, mare's	9.4	2.0	1.1	0	5.9	0.4	0.08	0.05	0.32	0.08
Milk, sow's	19.0	5.9	6.7	0	5.4	1.0	—	—	0.94	—
Milk albumin, or lactalbumin, commercial	92.0	49.5	0.9	1.0	12.8	27.8	—	—	7.92	—
Milk, whole, dried	96.8	24.8	26.2	0.2	40.2	5.4	—	—	3.97	—
Millet seed, foxtail varieties	89.1	12.1	4.1	8.6	60.7	3.6	—	0.20	1.94	0.31
Millet seed, hog, or proso	90.4	11.9	3.4	8.1	63.7	3.3	0.05	0.30	1.90	0.43
Millet seed, Japanese	89.8	10.6	4.9	14.6	54.7	5.0	—	0.44	1.70	0.33
Milo grain	89.4	11.3	2.9	2.2	71.3	1.7	0.03	0.30	1.81	0.36
Milo head chops	90.1	10.2	2.5	6.9	66.2	4.3	0.14	0.26	1.63	—
Molasses, beet	80.5	8.4	0	0	62.0	10.1	0.08	0.02	1.34	4.77
Molasses, beet, Steffen's process	78.7	7.8	0	0	62.1	8.8	0.11	0.02	1.25	4.66
Molasses, cane, or blackstrap	74.0	2.9	0	0	62.1	9.0	0.74	0.08	0.46	3.67
Molasses, cane, high in sugar	79.7	1.3	0	0	74.9	3.5	—	—	0.21	—
Molasses, citrus	69.9	4.0	0.2	0	61.3	4.4	—	—	0.64	—
Molasses, corn sugar, or hydrol	80.5	0.2	0	0	77.8	2.5	—	—	0.03	—
Mustard seed, wild yellow	95.9	23.0	38.8	5.0	23.6	5.5	—	—	3.68	—
Oat clippings, or clipped-oat by-product	92.2	8.8	2.3	25.3	44.9	10.9	—	—	1.41	—
Oat kernels, without hulls (oat groats)	90.4	16.3	6.1	2.1	63.7	2.2	0.08	0.46	2.61	0.39
Oat meal, feeding, or rolled oats without hulls	90.8	16.0	5.5	2.7	64.2	2.4	0.07	0.46	2.56	0.37
Oat middlings	91.4	15.9	5.2	3.3	64.6	2.4	0.08	0.45	2.54	0.57
Oat mill feed	92.4	5.6	1.8	27.9	50.8	6.3	0.13	0.16	0.90	0.60

508 ANALYSIS OF BASIC MATERIALS

Material	Total dry	Protein	Fat	Fiber	N-free	Total	Calcium	Phos-	Nitro-	Potas-
	matter	Per ct.	Per ct.	Per ct.	extract	minerals	Per ct.	phorus	gen	sium
	Per ct.	Per ct.	Per ct.	Per ct.	Per ct.	Per ct.	Per ct.	Per ct.	Per ct.	Per ct.
Oat mill feed, poor grade	92.4	4.3	1.8	30.5	50.2	5.6	—	—	0.69	—
Oat mill feed, with molasses	92.4	5.5	1.4	24.1	55.0	6.4	—	—	0.88	—
Oats, not including Pacific Coast states	90.2	12.0	4.6	11.0	58.6	4.0	0.09	0.34	1.92	0.43
Oats, Pacific Coast states	91.2	9.0	5.4	11.0	62.1	3.7	—	—	1.44	—
Oats, hull-less	90.0	15.4	4.2	2.6	65.7	2.1	—	—	2.46	—
Oats, light weight	91.3	12.3	4.7	15.4	54.4	4.5	—	—	1.97	—
Oats, wild	89.0	12.7	5.5	15.2	50.9	4.7	—	—	2.03	—
Olive pulp, dried, pits removed	95.1	14.0	27.4	19.3	31.0	3.4	—	—	2.24	—
Olive pulp, dried, with pits	92.0	5.9	15.6	36.5	31.5	2.5	—	—	0.94	—
Orange pulp, dried	87.9	7.7	1.5	8.0	67.3	3.4	—	—	1.23	—
Palm-kernel oil meal	91.4	19.2	6.7	11.9	49.7	3.9	—	0.69	3.07	0.42
Palm seed, Royal	86.5	6.1	8.3	22.8	43.8	5.5	—	—	0.98	—
Palmo middlings	94.1	16.1	9.7	6.7	56.3	5.3	—	—	2.58	—
Pea feed, or pea meal	90.0	17.7	1.4	23.7	43.7	3.5	—	—	2.83	—
Pea hulls of seeds, or bran	91.5	4.8	0.4	48.5	34.3	3.5	—	—	0.77	—
Pea seed, field	90.7	23.4	1.2	6.1	57.0	3.0	0.17	0.51	3.74	1.03
Pea seed, field, cull	89.7	24.8	2.5	7.1	52.0	3.3	—	—	3.97	—
Pea seed, garden	89.2	25.3	1.7	5.7	53.6	2.9	0.08	0.40	4.04	0.90
Peanut kernels, without hulls	94.6	30.4	47.7	2.5	11.7	2.3	0.06	0.44	4.86	—
Peanut oil feed	94.5	37.8	9.6	14.3	26.2	6.6	—	6.04	—	—
Peanut oil feed, unhulled, or whole pressed peanuts	93.1	35.0	9.2	22.5	21.4	5.0	—	—	5.60	—
Peanut oil meal, old process, all analyses	93.0	43.5	7.6	13.3	23.4	5.2	0.16	0.54	6.96	1.15
Peanut oil meal, o.p., 45% protein and over	93.4	45.2	7.4	12.1	23.7	5.0	—	—	7.23	—
Peanut oil meal, o.p., 43% protein grade	92.8	43.1	7.6	13.9	23.0	5.2	—	—	6.90	—
Peanut oil meal, o.p., 41% protein grade	93.8	41.8	7.8	12.7	25.9	5.6	—	—	6.69	—
Peanut oil meal, solvent process	91.6	51.5	1.4	5.7	27.2	5.8	—	—	8.24	—
Peanut skins	93.8	16.3	23.9	11.8	39.1	2.7	—	—	2.61	—
Peanut screenings	93.6	23.8	11.5	18.9	33.0	6.4	—	—	3.81	—
Peanuts, with hulls	94.1	24.9	36.2	17.5	12.6	2.9	—	0.33	3.98	0.53
Perilla oil meal	91.9	38.4	8.4	20.9	16.0	8.2	0.56	0.47	6.14	—
Pigeon-grass seed	89.8	14.4	6.0	17.3	45.8	6.3	—	—	2.30	—
Pigweed seed	90.0	16.8	6.2	15.9	47.8	3.3	—	—	2.69	—
Pineapple bran, or pulp, dried	85.3	4.0	1.9	19.4	57.2	2.8	0.20	0.10	0.64	—
Pineapple bran, or pulp, and molasses, dried	87.4	3.9	1.0	15.9	63.4	3.2	—	—	0.62	—
Poppy-seed oil meal	89.2	36.6	7.9	11.6	20.7	12.4	—	—	5.86	—
Potato meal, or dried potatoes	92.8	10.4	0.3	2.0	75.8	4.3	0.08	0.22	1.66	1.97
Potato pomace, dried	89.1	6.6	0.5	10.3	69.0	2.7	—	—	1.06	—
Pumpkin seed, not dried	55.0	17.6	20.6	10.8	4.1	1.9	—	—	2.82	—
Raisin pulp, dried	89.4	9.6	7.8	16.1	50.6	5.3	—	—	1.54	—
Raisins, cull	84.8	3.4	0.9	4.4	73.1	3.0	—	—	0.54	—
Rape seed	90.5	20.4	43.6	6.6	15.7	4.2	—	—	3.26	—
Rape-seed oil meal	89.5	33.5	8.1	10.8	30.2	6.9	—	—	5.36	—
Rice, brewers'	88.3	7.5	0.6	0.6	78.8	0.8	0.04	0.10	1.20	—
Rice, brown	87.8	9.1	2.0	1.1	74.5	1.1	0.04	0.25	1.46	—
Rice, polished	87.8	7.4	0.4	0.4	79.1	0.5	0.01	0.09	1.18	0.04

ANALYSIS OF BASIC MATERIALS 509

Material	Total dry matter	Protein	Fat	Fiber	N-free extract	Total minerals	Calcium	Phos-phorus	Nitro-gen	Potas-sium
	Per ct.	Per ct.	Per ct.	Per ct.	Per ct.	Per ct.	Per ct.	Per ct.	Per ct.	Per ct.
Rice bran	90.9	12.5	13.5	12.0	39.4	13.5	0.08	1.36	2.00	1.08
Rice grain, or rough rice	88.8	7.9	1.8	9.0	64.9	5.2	0.08	0.32	1.26	0.34
Rice polishings, or rice polish	89.8	12.8	13.2	2.8	51.4	9.6	0.04	1.10	2.04	1.17
Rubber seed oil meal	91.1	28.8	9.2	10.0	37.6	5.5	—	—	4.61	—
Rye grain	89.5	12.6	1.7	2.4	70.9	1.9	0.10	0.33	2.02	0.47
Rye feed	90.4	16.1	3.3	4.6	62.7	3.7	0.08	0.69	2.58	0.83
Rye flour	88.6	11.2	1.3	0.6	74.6	0.9	0.02	0.28	1½79	0.46
Rye flour middlings	90.6	16.5	3.5	4.2	63.1	3.3	—	—	2.64	—
Rye middlings	90.2	16.6	3.4	5.2	61.2	3.8	—	0.44	2.66	0.63
Rye middlings and screenings	90.4	16.7	3.8	6.1	59.5	4.3	—	—	2.67	—
Safflower seed	93.1	16.3	29.8	26.6	17.5	2.9	—	—	2.61	—
Safflower seed oil meal, from hulled seed	91.0	38.0	6.8	21.0	17.0	8.2	—	—	6.08	—
Safflower-seed oil meal from unhulled seed	91.0	18.2	5.5	40.4	24.1	2.8	—	—	2.91	—
Sagrain sorghum grain	90.0	9.5	3.5	2.1	73.4	1.5	0.43	0.39	1.52	—
Screenings, grain, good grade	90.0	15.8	5.2	9.2	54.3	5.5	—	—	2.53	—
Screenings, grain, chaffy	91.5	14.3	4.4	18.3	46.1	8.4	—	—	2.29	—
Schrock sorghum grain	89.1	10.2	3.0	3.4	70.8	1.7	—	—	1.63	—
Sesame oil meal	93.7	42.8	9.4	6.2	22.8	12.5	2.02	1.61	6.84	1.35
Sesbania seed	90.8	31.7	4.3	13.5	38.0	3.3	—	—	5.07	—
Shallu grain	89.8	13.4	3.7	1.9	68.9	1.9	—	—	2.14	—
Shallu head chops	90.5	12.7	3.5	9.2	61.9	3.2	—	—	2.03	—
Shark meal	91.2	74.5	2.7	0.5	0	13.5	3.48	1.92	12.69	—
Shrimp meal	89.7	46.7	2.8	11.1	1.3	27.8	—	—	7.47	—
Skimmilk, centrifugal	9.5	3.6	0.1	0	5.1	0.7	0.13	0.10	0.58	0.15
Skimmilk, gravity	10.1	3.6	0.8	0	5.0	0.7	0.13	0.10	0.58	0.15
Skimmilk, dried	94.2	34.7	1.2	0.2	50.3	7.8	1.30	1.03	5.56	1.46
Sorghum seed, sweet	89.2	9.5	3.3	2.0	72.8	1.6	0.02	0.28	1.52	0.37
Soybean seed	90.0	37.9	18.0	5.0	24.5	4.6	0.25	0.59	6.06	1.50
Soybean flour, medium in fat	92.9	47.9	6.7	2.4	29.9	6.0	—	—	7.66	—
Soybean flour, solvent extracted	91.5	48.5	0.8	2.6	33.0	6.6	—	—	7.76	—
Soybean mill feed, chiefly hulls	90.8	11.8	2.7	34.0	38.1	4.2	—	—	1.89	—
Soybean oil meal, expeller or hydraulic process, all analyses	90.0	44.3	5.3	5.7	29.6	6.0	0.29	0.66	7.09	1.77
Soybean oil meal, exp. or hydr. process, 44-45% protein guarantee	91.3	45.4	5.3	5.4	29.3	5.9	0.31	0.68	7.26	1.92
Soybean oil meal, exp. or hydr. process, 43% protein guarantee	91.2	44.6	5.3	5.8	29.4	6.1	0.30	0.67	7.14	—
Soybean oil meal, exp. or hydr. process, 41% protein guarantee	90.9	44.2	5.3	5.7	29.7	6.0	0.26	0.59	7.07	—
Soybean oil meal, solvent process	90.6	46.1	1.0	5.9	31.8	5.8	0.30	0.66	7.38	1.92
Starfish meal	96.5	30.6	5.8	1.9	14.3	43.9	—	—	4.90	—
Sudan-grass seed	92.4	14.2	2.4	25.4	38.4	12.0	—	—	2.27	—
Sunflower seed	93.6	16.8	25.9	29.0	18.8	3.1	—	0.55	2.69	0.66
Sunflower seed, hulled	95.5	27.7	41.4	6.3	16.3	3.8	0.20	0.96	4.43	0.92
Sunflower-seed oil cake, from unhulled seed, solvent process	89.2	19.6	1.1	35.9	27.0	5.6	—	—	3.14	—

# 510 ANALYSIS OF BASIC MATERIALS

Material	Total dry matter	Protein	Fat	Fiber	N-free extract	Total minerals	Calcium	Phosphorus	Nitrogen	Potassium
	Per ct.	Per ct.	Per ct.	Per ct.	Per ct.	Per ct.	Per ct.	Per ct.	Per ct.	Per ct.
Sunflower-seed oil cake, from hulled seed, hydr. process	90.6	36.3	13.5	14.2	20.2	6.4	0.43	1.04	5.81	1.08
Sweet clover seed	92.2	37.4	4.2	11.3	35.8	3.5	—	—	5.98	—
Sweet potatoes, dried	90.3	4.9	0.9	3.3	77.1	4.1	0.21	0.18	0.78	—
Tankage or meat meal, digester process, 60% protein grade	93.1	60.6	8.5	2.0	1.8	20.2	6.37	3.23	9.70	0.46
Tankage with bone, or meat and bone meal, digester process, 50% protein grade	93.5	51.3	11.5	2.3	2.3	26.1	10.97	5.14	8.21	—
Tankage with bone, or meat and bone meal, digester process, 40% protein grade	94.7	42.9	14.1	2.2	4.1	31.4	13.49	5.18	6.86	—
Tomato pomace, dried	94.6	22.9	15.0	30.2	23.4	3.1	—	—	3.66	—
Velvet bean seeds and pods (velvet bean feed)	90.0	18.1	4.4	13.0	50.3	4.2	0.24	0.38	2.90	1.20
Velvet beans, seeds only	90.0	23.4	5.7	6.4	51.5	3.0	—	—	3.74	—
Vetch seed	90.7	29.6	0.8	5.7	51.5	3.1	—	—	4.74	—
Whale meal	91.8	78.5	6.7	0	3.1	3.5	0.56	0.57	12.56	—
Wheat, average of all types	89.5	13.2	1.9	2.6	69.9	1.9	0.04	0.39	2.11	0.42
Wheat, hard spring, chiefly northern plains states	90.1	15.8	2.2	2.5	67.8	1.8	—	—	2.53	—
Wheat, hard winter, chiefly southern plains states	89.4	13.5	1.8	2.8	69.2	2.1	—	—	2.16	—
Wheat, soft winter, Miss. valley and eastward	89.2	10.2	1.9	2.1	73.2	1.8	—	—	1.63	—
Wheat, soft, Pacific Coast states	89.1	9.9	2.0	2.7	72.6	1.9	—	—	1.58	—
Wheat bran, all analyses	90.1	16.9	4.6	9.6	52.9	6.1	0.14	1.29	2.70	1.23
Wheat bran, chiefly hard spring wheat	91.1	17.9	4.9	10.1	52.2	6.1	0.13	1.35	2.86	—
Wheat bran, soft wheat	90.5	16.1	4.3	8.7	55.7	5.7	—	—	2.58	—
Wheat bran, winter wheat	89.9	15.5	4.2	8.9	55.1	6.2	—	—	2.48	—
Wheat bran and screenings, all analyses	90.0	16.8	4.5	9.6	53.0	6.1	0.14	1.21	2.69	—
Wheat brown shorts	88.7	16.9	4.2	7.1	56.0	4.5	—	—	2.70	—
Wheat brown shorts and screenings	88.7	17.0	4.1	7.0	56.0	4.6	—	—	2.72	—
Wheat flour, graham	88.1	12.5	1.9	1.8	70.4	1.5	0.04	0.36	2.00	0.46
Wheat flour, low grade	88.4	15.4	1.9	0.5	69.7	0.9	—	—	2.46	—
Wheat flour, white	88.0	10.8	0.9	0.3	75.6	0.4	0.02	0.09	1.73	0.05
Wheat flour middlings	89.2	18.3	4.2	3.8	59.8	3.1	0.09	0.71	2.93	0.89
Wheat flour middlings and screenings	89.6	18.2	4.5	5.2	57.8	3.9	0.14	0.68	2.91	—
Wheat germ meal, commercial	90.8	31.1	9.7	2.6	42.2	5.2	0.08	1.11	4.98	0.29
Wheat germ oil meal	89.1	30.4	4.9	2.6	46.4	4.8	—	—	4.86	—
Wheat gray shorts	88.9	17.9	4.2	5.7	56.9	4.2	0.13	0.84	2.86	—
Wheat gray shorts and screenings	88.6	17.6	4.0	5.8	57.0	4.2	—	—	2.82	—
Wheat mixed feed, all analyses	89.7	17.2	4.5	7.2	56.1	4.7	0.11	1.09	2.76	—
Wheat mixed feed, hard wheat	89.8	18.7	4.8	7.7	53.6	5.0	0.11	1.09	2.99	—
Wheat mixed feed and screenings	89.3	17.5	4.3	7.1	55.7	4.7	0.11	0.96	2.80	—
Wheat red dog	89.0	18.2	3.6	2.6	61.9	2.7	0.07	0.51	2.91	0.60
Wheat red dog, low grade	89.2	17.9	4.8	4.9	57.9	3.7	—	—	2.86	—
Wheat screenings, good grade	90.4	13.9	4.7	9.0	58.2	4.6	0.44	0.39	2.22	—
Wheat standard middlings, all analyses	89.6	18.1	4.8	6.5	55.8	4.4	0.09	0.93	2.90	1.04

Material	Total dry matter		Protein Per ct.	Fat Per ct.	Fiber Per ct.	N-free extract Per ct.	Total minerals Per ct.	Calcium Per ct.	Phos- phorus Per ct.	Nitro- gen Per ct.	Potas- sium Per ct.
	Per ct.	Per ct.									
Wheat standard middlings and screenings, all analyses	89.7	18.0	4.7	7.4	55.1	4.5	0.15	0.88	2.88	—	
Wheat white shorts	89.7	16.1	3.1	2.9	65.0	2.6	—	—	2.58	—	
Whey, from cheddar cheese	6.9	0.9	0.3	0	5.0	0.7	0.05	0.04	0.14	0.19	
Whey, skimmed	6.6	0.9	0.03	0	5.0	0.7	—	—	0.14	—	
Whey, condensed	57.3	8.8	0.6	0	42.0	5.9	—	—	1.41	—	
Whey, dried	93.5	12.2	0.8	0.2	70.4	9.9	0.86	0.72	1.96	—	
Whey solubles, dried	96.3	17.5	2.0	0	62.8	14.0	—	—	2.80	—	
Yeast, brewers', dried	93.8	49.3	1.0	3.7	31.9	7.9	0.13	1.56	7.89	—	
Yeast, irradiated, dried	93.9	48.7	1.1	5.5	32.2	6.4	0.07	1.55	7.79	2.14	
Yeast, dried, with added cereal	90.2	12.3	3.7	3.2	68.5	2.5	0.09	0.45	1.97	—	
Yeast, molasses distillers', dried	91.0	38.8	1.9	6.1	30.2	14.0	—	—	6.21	—	

(These tables have been adapted from "U.S.-Canadian Tables of Feed Composition"; Publication 1684; Committee on Animal Nutrition and National Committee on Animal Nutrition, Canada, National Academy of Sciences—National Research Council, Washington, D.C. 1969)





# Data Conversion Tables

## Weights & Volumes

1 liter water = 1000 ml. = 1000 grams = 1 kilogram = 2.205 lbs.  
1 gallon water = 3785 ml. = 133.44 ounces = 3.785 liters = 8.34 lbs.  
1 cubic foot water = 62.41 lbs. at 10°C.

1 gallon = 4 quarts = 3.79 liters  
1 quart = 32 fluid ounces = .95 liters  
2 cups = .47 liters

1 cubic inch = 16.3872 cubic centimeters  
1 cubic foot = .0283 cubic meters  
1 cubic yard = .7646 cubic meters

1 cubic yard = 324 square feet 1 inch deep  
81 square feet 4 inches deep  
27 square feet 12 inches deep

1 cubic centimeter = .0610 cubic inches  
1 cubic meter = 35.3145 cubic feet  
1 cubic meter = 1.3079 cubic yards

1 pound = 16 ounces = .4536 kilograms = 454 grams  
1 ounce = 28.35 grams

1 net ton = 2000 pounds = .907 metric tons  
1 metric ton = 1000 kilograms  
1 gross ton = 2240 pounds = 1.016 tons

---

---

## Temperature

$$1^{\circ} \text{F} = .555^{\circ} \text{Kelvin}$$

$$1^{\circ} \text{F} = (.555 (\text{F}-32) + 273)$$

$$0^{\circ} \text{K} = -273^{\circ} \text{C.}$$

$$\text{C} = 5/9 (\text{F}-32)$$

$$\text{F} = 9/5^{\circ} \text{C} + 32$$

<u>0° C = 32° F.</u>
5° C = 41° F.
10° C = 50° F.
15° C = 59° F.
20° C = 68° F.
25° C = 77° F.
30° C = 86° F.
35° C = 95° F.
40° C = 104° F.
45° C = 113° F.
50° C = 122° F.
100° C = 212° F.
200° C = 392° F.

<u>0° F = -17.8° C</u>
5° F. = -15.5° C.
10° F. = -12.2° C.
15° F. = -9.4° C.
20° F. = -6.7° C.
25° F. = -3.9° C.
30° F. = -1.1° C.
35° F. = 1.6° C.
40° F. = 4.4° C.
45° F. = 7.2° C
50° F. = 10.0° C.
60° F. = 18.3° C.
70° F. = 21.2° C.
80° F. = 26.7° C.
90° F. = 32.2° C.
95° F. = 35.0° C.
100° F. = 37.8° C.
120° F. = 48.9° C.
140° F. = 60.0° C.
160° F. = 71.1° C.
180° F. = 82.2° C.
200° F. = 93.4° C.

## Heat Energy

1 calorie = the heat energy to raise to 1 gram (1 ml.) H<sub>2</sub>O 1° C.  
1 BTU = 252 calories = the heat energy to raise 1 pound H<sub>2</sub>O 1° F.

## Light

1 foot-candle = 10.7639 lux = the amount of light from 1 lumen from a distance of 1 foot over the surface area of 1 square foot.

1 lux = 1 lumen at a distance of 1 meter over a surface area of 1 square meter.



## Pressure & Power

1 horsepower = 746 watts

1 kilogram/square centimeter = 14.233 pounds per square inch

1 pound/square inch = .0703 kilograms per square centimeter

1 kilogram per square meter = .2048 pounds per square foot

1 atmosphere pressure = 1.0332 kilograms per square centimeter  
= 4.696 pounds per square inch.  
= 1.0133 bars

---

---

## Miscellaneous Data

1 level tablespoon of malt/agar (50:50) media = approximately 7 grams

1 US 5 cent piece (nickel) = approximately 5 grams

50 pounds of dry rye grain = approximately 125 cups

100 grams of dry rye grain = approximately 125 milliliters

1 standard U.S. glass gallon "mayonnaise" jar = 3800 milliliters when filled to brim

1 dry ton finely chopped wheat straw, when wetted and compressed, occupies approximately 200-250 cubic feet.

1 ton compost (straw/manure) = 2 cubic yards = 70 square feet of beds (10-12 inches deep).

1 yard fresh alder sawdust = approximately 700 lbs.

Household bleach = 5% sodium hypochlorite

1 tablespoon bleach/gallon water = 200 ppm chlorine

1 cup household bleach/gallon = 3200 ppm chlorine

---

---



# Glossary

## A

**agar:** a product derived from seaweed, valued for its gelatinizing properties, and commonly used for to solidify nutritied media for sterile tissue culture.

**agarics:** mushrooms with gills.

**anamorph:** forms of mycelia which do not include basidia.

**anastomosis:** the fusion of hyphal cells followed by an exchange of cellular contents between two mycelial networks.

**annulus:** a ring, a collar or cellular skirt forming on the stem, typically originating from a portion of the partial veil.

**appressed:** flattened.

**ascus, asci:** a sac-like cell typical of the Class Ascomycetes, usually containing 6 or 8 spores. Most cup fungi and morels (*Morchella*) belong to this group.

**autoclave:** a steam pressurized vessel used for heat treating.

## B

**Basidiomycetes:** fungi which bear spores upon a club-like cell known as a basidium. Pore, tooth, and jelly fungi (*Auricularia* spp.) belong to this Class.

**basidia:** the club like cells which give rise to four (more rarely 2 or 6) spores

**Basidiomycetes:** the Class of fungi producing spores on basidia. The gilled, pored, toothed and some cup mushrooms are basidiomycetes.

**biological efficiency:** the percentage measurement of the yield of fresh mushrooms from the dry weight of the substrate. (See Page 57.) 100% biological efficiency is equivalent to saying that from a substrate with a moisture content of 75%, 25% of its mass will yield fresh mushrooms having a moisture content of 90%.

**bleach-bombing:** an industry used phrase to describe the use of bleach being sprayed on the walls and floors. The rooms so treated are usually sealed tight for 24 hours, allowing the chlorine gas to thoroughly disinfect the environment.

**block:** a term used in mushroom culture, referring to the cube-shaped mass of sawdust substrate contained within plastic bags. Once the mycelium has grown through the substrate, the plastic can be stripped off, and the mycelium holds the mass together. Blocks can be used individually or collectively to build "walls" of mushroom mycelium.

**brown rot:** a condition caused the degradation of cellulose by fungi which leaves the substrate brown in color. The brown color is largely due to undecomposed lignin. Solid blocks of wood are used for testing whether or not a fungus causes "brown rot" or "white rot".

## C

**capitate:** having a swollen head.

**carpophore:** the fruiting body of higher fungi.

**casings:** a layer of water retentive materials applied to a substrate to encourage and enhance fruitbody production.

**chlamydospores:** thick walled, secondary spores developing from hyphae but not from basidia, nor from conidiophores.

**cheilocystidia:** variously shaped, sterile cells on the gill edge of mushrooms.

**clamp connection:** a small, semicircular, hollow bridge that is laterally attached to the walls of two adjoining cells and spanning the septum between them. See Page 67.

**collyboid:** resembling mushrooms typical of the genus *Collybia*—groups of mushrooms clustered together at the base and having convex to plane caps.

**conidia:** a uninucleate, exteriorly borne cell formed by constriction of the conidiophore.

**conidiophore:** a specialized structure arising from mycelium upon which conidia are borne.

**conspecific:** equal to, i.e. two taxa are in fact the same species.

**contamination:** any organism other than the one desired to be cultivated.

**context:** the internal flesh of mushroom, existing between the differentiated outer layers of the mushroom.

**coprophilic:** dwelling on, and having an affection for manure.

**coremia:** a bundle of reproductive structures (conidiophores). Some *Pleurotus* species (*P. cystidiosus*, *P. abalonus* & *P. smithii*) produce coremic structures in culture—often black

---



droplets of spore bundles on relatively long stalks. Once the droplets dry, the spores become airborne. See Pages 73, 112.

**cystidia:** microscopic, sterile cells arising from the gill, cap or stem.

## D

**deciduous:** used to describe trees that seasonally shed their leaves.

**decurrent:** the attachment of the gill plates to the stem of a mushroom where the gills partially run down the stem.

**deliquescing:** the process of auto-digestion by which the gills and cap of a mushroom melt into a liquid. Typical of some members in the genus *Coprinus*.

**dikaryotic:** the state wherein two individual genetically different nuclei are present in each fungal cell.

**dimitic hyphae:** fungal flesh typified by two kinds of hyphae, usually generative and skeletal.

**dimorphic:** having two forms

**diploid:** a genetic condition wherein each cell has a full complement of chromosomes necessary for sexual reproduction, denoted as 2N.

**disc:** the central portion of the mushroom cap.

## E

**eccentric:** off-centered.

**ellipsoid:** oblong shaped.

**endospores:** spores formed internally.

**entheogen:** any naturally occurring substance which, when ingested, produces a profound religious state of mind, often described as God-like.

**evanescent:** fragile and soon disappearing.

## F

**farinaceous:** grain-like, usually in reference to the scent of mycelium or mushrooms.

**fermentation:** the state of actively growing microorganisms, usually in a liquid environment.

**fibrillose:** having fibrils, or small "hairs"

**filamentous:** composed of hyphae or thread-like cells.

**flexuose, flexuous:** bent alternatively in opposite directions.

**flush:** a crop of mushrooms, collectively forming within a defined time period, often repeating in a rhythmic fashion.

**foot candle:** a measurement of the intensity of light, equivalent to 10.7639 lux. A foot candle is the amount of light from 1 lumen at a distance of 1 foot over a surface area of 1 square foot.

**fruitbody:** the mushroom structure.

**fruiting:** the event of mushroom formation and development.

## G

**generative hyphae:** the thin walled, branched, and narrow cells that give rise to the spore producing layers and surface tissues. Species typified by clamp connections will have clamps at the septa of the generative hyphae.

**genotype:** the total genetic heritage of constitution of an organism, from which individual phenotypes are expressed.

**Gram (Gram's Stain):** A method for separating bacteria whereby bacteria are stained first with crystal violet (a red dye) and then washed with an iodine solution. Gram positive bacteria retain the dye. Gram negative bacteria lose the dye.

**gypsum:** calcium sulfate:  $\text{CaSO}_4 \times 2 \text{H}_2\text{O}$ . A buffer used in spawn making to keep grain kernels separated. Calcium sulfate slightly acidifies a substrate as sulphuric acids evolve.

## H

**heterothallic:** having two or more morphologically similar pairs of strains within the same species. The combination of compatible spore types is essential for producing fertile offspring.

**homothallic:** having one strain type that is dikaryotic and self-fertile, typically of mushrooms which produce two spores on a basidium.

**hygrophanous:** fading markedly in color upon drying.

**hymenium:** the fertile outer layer of cells from which basidia, cystidia and other cells are produced.

**hymenophore:** the fertile portion of the mushroom bearing the hymenium.

**hypha, hyphae (pl.):** the individual fungal cell.

**hyphal aggregates:** visible clusters of hyphae, resembling cottony tufts of mycelium, often preceding but not necessarily leading to primordia formation.

**hyphosphere:** the microscopic environment in direct proximity to the hyphae.

## K

**karyogamy:** the fusion of two sexually opposite nuclei within a single cell.

## L

**lageniform:** thin and sinuous

**lamellae:** the gills of a mushroom, located on the underside of the cap.

**lamellulae:** the short gills, originating from the edge of the outer peripheral edge of cap but not fully extending to the stem.

**lignicolous:** growing on wood or a substrate composed of woody tissue.

**lignin:** the organic substance which, with cellulose, forms the structural basis of most woody tissue.

**lumen:** the amount of the flow of light emitted from a single international foot candle.

**lux:** a measurement of light received by a surface equal to 1 lumen at a distance of 1 meter over a surface area of 1 square meter.

## M

**macroscopic:** visible to the naked eye.

**membranous:** being sheath-like in form.

**meiosis:** the process of reduction division by which a single cell with a diploid nucleus subdivides into four cells with one haploid nucleus each.

**mesophile:** an organism thriving in moderate temperature zone, usually between 40-90° F. (4-32° C.)

**micron:** 1,000,000th of a meter.

**mitosis:** the non-sexual process of nuclear division in a cell by which the chromosomes of one nucleus are replicated and divided equally into two daughter nuclei.

**monokaryon:** the haploid state of the mushroom mycelium, typically containing one nucleus.

**monomitic:** fungal flesh consisting only of thin walled, branched and narrow (generative) hyphae.

**mycelium:** a fungal network of thread-like cells.

**mycology:** the study of fungi.

---

**mycophagist:** a person or animal that eats fungi.

**mycophile:** a person who likes mushrooms.

**mycophobe:** a person who fears mushrooms.

**mycorrhizal:** a symbiotic state wherein mushroom mycelium forms on or in the roots of trees and other plants.

**mycosphere:** the environment in which the mycelium operates.

**mycotopia:** a term coined by Paul Stamets to describe an environment in which fungi are actively used to enhance and/or preserve ecological equilibrium.

## N

**natural culture:** the cultivation of mushrooms outdoors, benefitting from natural weather conditions.

**nucleus:** a concentrated mass of differentiated protoplasm in cells containing chromosomes and playing an integral role in the reproduction and continuation of genetic material.

## O

**oidia:** conidia (spores) borne in chains.

## P

**pan/panning:** the die-back of mycelium caused by a variety of reasons, primarily sudden drying after wetting.

**parasite:** an organism living on another living species and deriving its sustenance to the detriment of the host.

**partial veil:** the inner veil of tissue extending from the cap margin to the stem and at first covering the gills of mushrooms.

**pasteurization:** the rendering of a substrate to a state where competitor organisms are at a disadvantage, allowing mushroom mycelium

to flourish. Steam or hot water is usually used; biological and chemical pasteurization are alternative methods.

**phenotype:** the observable physical characteristics expressed from the genotype.

**photosensitive:** sensitive to light.

**phototropic:** growing towards light.

**pileocystidia:** sterile cells on the surface of the cap.

**pileus:** the mushroom cap.

**pinhead:** a dot-like form which develops into a mushroom. The pinhead is the earliest, visible indication of mushroom formation.

**pleurocystidium, pleurocystidia** (pl.): the sterile cells on the surface of mushroom gills, distinguished from those sterile cells occurring on their outer edges.

**primordium, primordia:** the mushroom at the earliest stage of growth, synonymous with "pinhead". See Pages 68, 114.

**psilocybian:** containing psilocybin and/or psilocin.

## R

**radicate:** tapering downwards downwards. Having a long root-like extension of the stem.

**rhizomorph:** a thick string-like strand of mycelium. A rhizomorph can consist of one enlarged cell or many, usually braided.

**rhizosphere:** the space encompassing the rhizomorph or the zone around the roots of plants.

## S

**saprophyte:** an organism that lives on dead organic matter.

**sclerotium, sclerotia:** a resting stage of mycelium typified by a mass of hardened mycelium resembling a tuber and from which mushrooms, mycelia, or conidia can arise. Sclerotia are produced by both ascomycetes and basidiomycetes.

**sector:** usually used to describe fans of mycelium morphologically distinct from the type of mycelium preceding and bordering it.

**senescence:** the state whereby a living organism declines in vigor due to age and becomes susceptible to disease.

**septum, septa** (pl.) structural divisions between cells, i.e. cell walls.

**septate:** cells with distinct walls.

**skeletal hyphae:** coarse, inflated cellular network consisting of thick-walled, unbranched, cells lacking cross-walls. Skeletal hyphae give mushrooms a tough, fibrous texture, especially at the stem base. Except for the basal cell, they are typically clamp-less.

**spawn:** any material impregnated with mycelium, the aggregation of which is used to inoculate more massive substrates.

**species:** a biologically discrete group of individuals which are cross-fertile, and give rise to fertile progeny.

**sporeless strains:** Strains which do not produce spores. Sporeless Oyster strains are highly sought after given the health problems associated with growing these mushrooms indoors.

**spores:** discrete cells which are used to spread fungi to new ecological niches, and are essential in the recombination of genetic material.

**sporocarps:** any fruitbody that produces spores.

**sterilization:** the rendering of a substrate to a state where all lifeforms have been made inviable. Sterilization by heat (steam) is more commonly employed in mushroom cultivation than chemical, gas, UV, or radioactive means. Sterilization usually implies prolonged exposure to temperatures at or above the boiling point of water (100° C; 212° F.) at or above atmospheric pressure.

**stipe:** the stem of a mushroom.

**strain:** a race of individuals within a species sharing a common genetic heritage but differing in some observable set of features which may or may not be taxonomically significant.

**stroma:** a dense, cushion-like aggregation of mycelium forming on the surface of substrate which generally does not lead to fruitbody formation.

**subhymenium:** the layer of cells directly below the hymenium.

**substrate:** straw, sawdust, compost, soil, or any organic material on which mushroom mycelium will grow.

**super-pasteurization:** prolonged pasteurization utilizing steam. Super-pasteurization typically is for 12-48 hours at or near to 100° C. (212° F.) at or near atmospheric pressure. Super-pasteurization is a method commonly used to render sawdust substrates, in bulk, into a form usable for the cultivation of Shiitake, Oyster, and/or similar mushrooms.

## T

**taxon (taxa pl.):** a taxonomic unit, usually in reference to a species.

**thermogenesis:** the natural and spontaneous escalation of temperature in substrates due to

---

metabolic heat released as fungi, bacteria and other microorganisms flourish.

**through-spawning:** mixing spawn evenly throughout the substrate.

**top-spawning:** placing spawn as a layer on the top of a substrate.

**trama:** the internal layers of cells between the gills of mushrooms.

### U

**universal veil:** an outer layer of tissue enveloping the cap and stem of some mushrooms, best seen in the youngest stages of fruitbody development.

### V

**variety:** a sub-species epithet used to describe

a consistently appearing variation of a particular mushroom species.

**veil:** a tissue covering mushrooms as they develop.

**vector:** the pathway through, or carrier on which an organism travels.

### W

**wedge-transfer:** the cutting of triangular shaped sections of mycelium from agar and their transfer into other vessels or substrates.

**white rot:** a condition whereby a substrate is rendered light in color from the decomposition of lignin ("delignification") and/or cellulose & hemicellulose from fungi. Solid blocks of wood are used for testing.

---



# Bibliography

- Adachi, K., H. Nanba, & H. Kuroda, 1987. Potential of host-mediated antitumor activity in mice by beta-glucan obtained from *Grifola frondosa* (Maitake). *Chem. Pharm. Bull.* 35: 262.
- Adachi, K., H. Nanba, M. Otsuka, & H. Kuroda, 1988. Blood pressure-lowering activity present in the fruit body of *Grifola frondosa* (Maitake). *Chem. Pharm. Bull.* 36(3):1000-1006.
- Adaskaveg, J.E. & R.L. Gilbertson, 1986. *Mycologia* 78: 694-705.
- \_\_\_\_\_. 1987. Vegetative incompatibility between intraspecific pairings of *Ganoderma lucidum* and *G. tsugae*. *Mycologia* 79:603-613.
- Ainsworth, G.C. 1971. *Dictionary of fungi*, 6th ed. Commonwealth Mycological Institute, Kew, Surrey, England.
- Ammirati, J. 1991-1993. Personal communications.
- Ando, M., 1974. Fruitbody formation of *Lentinus edodes* (Berk.) Sing. on the artificial media. *Mushroom Science IX* (Part I). Proceedings of the Ninth International Scientific Congress on the Cultivation of Edible Fungi, Tokyo.
- Anselmi, N. & G. Deandrea, 1979. Culture de *Pleurotus ostreatus* (Jacq.) Quel. sur du bois de salicacees: applications pratiques et risques eventuels de diffusion hemiparasitaire. *Mushroom Science X* (Part 2: 451-461.
- Arita, I., 1979. The mechanism of spontaneous dikaryotization in hyphae of *Pholiota nameko*. *Mycologia* 71: 603-611.
- Arnolds, E. 1992. Mapping and monitoring of macromycetes in relation to nature conservation. *McIlvainea* 10: 2, 4-27.
- Arora, D. 1979, (2nd ed., 1986). *Mushrooms demystified*. Ten Speed Press, Berkeley.
- \_\_\_\_\_. 1992. *All that the rain promises*. Ten Speed Press, Berkeley.
- \_\_\_\_\_. 1992. Personal communication.
- Azizi, K.A., T.R. Shamala, & K.R. 1990. Cultivation of *Pleurotus sajor-caju* on certain agro-industrial wastes and utilization of the residues for cellulase and D-xylanase production. *Mushroom Journal for the Tropics* (10)1: 21-26.

- Badham, E.R., 1985. The influence of humidity upon transpiration and growth in *Psilocybe cubensis*. *Mycologia* 77: 932-939.
- \_\_\_\_\_. 1988. Is autoclaving Shiitake substrate necessary? *Mushroom Journal for the Tropics* (8): 129-136.
- Bano, Z., S. Rajarathnam, & N. Nagaraja. Some aspects on the cultivation of *Pleurotus flabellatus* in India. *Mushroom Science* X, Part 2: 597-607.
- Bano, Z., S. Rajarathnam, 1981. Studies on the cultivation of *Pleurotus sajor-caju*, *Mushroom Journal* 101, pp. 243-245.
- Benjamin, D.R., *Mushrooms: poisons and panaceas*, 1995. W.H. Freeman & Co., New York.
- Bessette, A. 1988. *Mushrooms of the Adirondacks: a field guide*. North Country Books, Utica, New York.
- Bigwood, J. 1992. Personal communication.
- Blanchart, R.A., B. Compton, N. Turner, & R. Gilbertson, 1992. Nineteenth century shaman grave guardians are carved *Fomitopsis officinalis* sporophores. *Mycologia* 84(1), pp. 119-124. New York Botanical Garden, Bronx, New York
- Bo, L. and B. Yun-sun. 1980. *Fungi pharmacopoeia (Sinica)*. The Kinoko Company, Oakland, Ca.
- Bononi et al., 1991. *Pleurotus ostreatoroseus* cultivation in Brazil. *Mushroom Science* XI, A.A. Balkema, Netherlands.
- Bresinski, A., O. Hilber and HP Molitoris, 1977. The genus *Pleurotus* as an aid for understanding the concept of species in basidiomycetes. p. 229-259 in *The Species Concept in Hymenomycetes*, Cramer, Valduz.
- Bresinski, A., M. Fischer, B. Meixner and W. Paulus, 1987. Speciation in *Pleurotus*. *Mycologia* 79: 234-245.
- Brooke-Webster, D., 1987. The use of polyethylene film to control fructification of *Pleurotus* species on horizontal trays. *Developments in Crop Science X: Cultivating Edible Fungi*. Elsevier, Oxford.
- Brough, J. 1971. Soma and *Amanita muscaria*. *Bulletin of the School of Oriental and African Studies* (BSOAS) 34: 2, pp. 331-362.
- Buller, A.K., 1934. *Researches on Fungi* 6. Longmans, Green & Co., London, p. 310-324.
- Calzada, J.F., E. de Porres, R. de Leon, C. Rolz, & L.F. Franco, 1987. Production of food and feed from wheat straw by *Pleurotus sajor-caju*. *Mushroom Journal of the Tropics* (7): 45-46.
- Chang, S.C., J.A. Buswell & S.W. Chiu. *Mushroom biology & mushroom products*. The Chinese University Press.
- Chang, S.T. 1972. *The Chinese mushroom (Volvariella volvacea): morphology, cytology, genetics, nutrition and cultivation*. The Chinese University of Hong Kong, Hong Kong.
-



- Chang, S.T. & W.A. Hayes, 1978. *The Biology and Cultivation of Edible Mushrooms*. Academic Press, New York.
- Chang, S.T. & P.G. Miles, 1987. Historical record of the early cultivation of *Lentinus* in China. *Mushroom Journal of the Tropics* 7, 47.
- \_\_\_\_\_. 1989. *Edible mushrooms and their cultivation*. CRC Press, Boca Raton, Florida.
- Chang, S.T., J.A. Buswell & P.G. Miles (eds.), 1992. *Genetics and breeding of edible mushrooms*. Gordon & Breach Science Publishers, New York.
- Chantarasnit, A. 1989. Factors affecting contamination in plastic bag cultivation of the black mushroom (*Lentinus edodes*). *Mushroom Journal of the Tropics* (9): 15-20.
- Chen, Guo-Liang, 1992. Studies on the cultivation on the and medicinal efficacy of *Hericium erinaceus*. Translation. The Edible Fungi Research Institute of The Shanghai Academy of Agricultural Science, China.
- Chihara, G., 1978. Antitumor and immunological properties of polysaccharides from fungal origin. National Cancer Institute, Tokyo. *Proceedings of the Tenth International Congress on the Science and Cultivation of Edible Fungi*, France.
- Chilton, J., 1986. Grow the garden giant. *Mushroom* 14:5, no. 1, pgs. 17-19.
- Chu-Chous, M., 1983. Cultivating edible forest mushrooms. Vol. 119. *What's New in Forest Research*. Forest Research Institute, Rotorua, New Zealand.
- Chung H.C. and H.K. Joo, 1989. Selection of Superior Strain and Development of Artificial Culture Method of *Grifola frondosa*.
- Clemencon, H. & J.M. Moncalvo, 1990. Taxonomic analysis of cultural characters in the group *Lyophyllum shimeji* (Agaricales, Basidiomycetes) from Japan. *Transactions of the Mycological Society of Japan* 31: 479-488.
- Cochran, K.W., 1978. Medical effects in *The Biology & Cultivation of Edible Mushrooms*. Academic Press, New York.
- Cochran, K. 1989. Personal communication. *Mushrooms and cancer*. Unpublished bibliography on the anti-cancer properties of mushrooms.
- Corner, E.J.H., 1981. The agaric genera *Lentinus*, *Panus*, and *Pleurotus*. Nova Hedwigia, J. Cramer.
- Costantin, J. 1936. La culture de la morille et sa forme conidienne. *Ann. Sci. Nat. Bot.* (Ser.10)18: 111-129
- Crisan, E.V. & A. Sands, 1978. Nutritional value in *The Biology & Cultivation of Edible Mushrooms*. Academic Press, New York.
- Czarnecki, J. 1988. *Joe's book of mushroom cookery*. Atheneum/Macmillan Publishing Co., New York, N.Y.
- Donoghue, D.C., 1962. New light on fruitbody formation. *Mushroom Science* V: 247-249.

- Eger, G., 1974. The action of light and other factors on sporophore initiation in *Pleurotus ostreatus*. *Mushroom Science IX* (1): 575-583.
- Eger, G., G. Eden, and E. Wissig, 1976. *Pleurotus ostreatus* - breeding potential of a new cultivated mushroom. *Theor. Appl. Genet.* 47: 155-163.
- Eger, G., S.F. Li, and H. Leal-lara, 1979. Contribution to the discussion on the species concept in the *Pleurotus ostreatus* complex. *Mycologia*, 71: 577-588.
- Eger, G., 1980. Blue light photomorphogenesis in mushrooms. *The blue light syndrome*: 556-562. Springer-Verlage, Berlin.
- El-Kattan, M.H., Y. Gali, E.A. Abdel-Rahim, & A.Z.M. Aly, 1990. Submerged production of *Pleurotus sajor-caju* on bagasse hydrolyzate medium. *Mushroom Journal of Tropics* 10: 105-114.
- El-Kattan, M.H., Z.A. Helmy, M. A. E. El-Leithy, & K.A. Abdelkawi, 1991. Studies on cultivation techniques and chemical composition of Oyster mushrooms. *Mushroom Journal of the Tropics* (11) 59-66.
- Eugenio, C.P. & N.A. Anderson, 1968. The genetics and cultivation of *Pleurotus ostreatus*. *Mycologia* 60: 627- 634.
- Farr, D. 1983. Mushroom industry: diversity with additional species in the United States. *Mycologia* 75(2): 351-360.
- Fincham, J.R.S., P.R. Day & A. Radford, 1979 (4th ed.). *Fungal genetics*. Blackwell Scientific Publications, Oxford.
- Finkenstein, David B. & C. Ball, 1991. *Biotechnology of filamentous fungi*. Butterworth-Heinemann, Boston.
- Fisher, D.W. & Alan E. Bessette, 1992. *Edible mushrooms of North America: a field-to-kitchen guide*. University of Texas Press, Austin, Texas.
- Flegg, P.B., D.M. Spencer & D. A. Wood, 1985. *The biology and technology of the cultivated mushroom*. John Wiley & Sons, Chichester, U.K.
- Fletcher, J.T., R.F. White, & R.H. Gaze, 1986. Mushrooms: pest and disease control. *Intercept*, Andover, Hants. U.K.
- Fox, F.M., 1983. Role of basidiospores as inocula for mycorrhizal fungi of birch. *Tree Root Systems and their Mycorrhizas*. Nijhoff, The Hague.
- Fukuoka, M. 1978. *The One-Straw Revolution*. Rodale Press, Emmaus, Pa.
- Fujii, T., H. Maeda, F. Suzuki, & N. Ishida, 1978. Isolation and characterization of a new antitumor polysaccharide, KS- 2, extracted from cultured mycelia of *Lentinus edodes*. *Journal of Antibiotics* 31 (1): 1079-1090.
- Fujimoto, T., 1989. High speed year-round shiitake cultivation. *Shiitake News* 5 & 6.
- Gilbert, F.A., 1960. The submerged culture of *Morchella*. *Mycologia* 52: 201-209.
- Gilbertson R. & Ryvarde L. 1986. *North american polypores: Vol. I & II*. FungiFlora, Oslo, Norway.

- Gormanson, D. & M. Baughman, 1987. Financial analysis of three hypothetical, small scale Shiitake mushroom production enterprises. University of Minnesota Department of Forest Resources.
- Graham, K.M., R.M. Herbagiandono & M.E. Marvel, 1980. Cultivation of *Pleurotus flabellatus* on agricultural wastes in Indonesia. *Mushroom Newsletter for the Tropics*, Vol. 1: 1, pp.17-18.
- Guiochon, P.F.H.G.F., 1958. U.S. #2,851,821. U.S. Patent Office, Washington, D.C.
- Gunde-Cimerman, N.G. and A. Cimerman, 1995. *Pleurotus* fruiting bodies contain the inhibitor of 3-hydroxy-3-methylglutaryl-Coenzyme A Reductase-Lovastatin. *Experimental Mycology* 19: 1-6.
- Guzman, G. & J. Ott, 1976. Description and chemical analysis of a new species of hallucinogenic *Psilocybe* from the Pacific Northwest. *Mycologia* 68: 1261-1267.
- \_\_\_\_\_, J. Ott, J. Boydston, & S. H. Pollock, 1976. Psychotropic mycoflora of Washington, Idaho, Oregon, California, and British Columbia. *Mycologia* 68: 1267- 1272.
- \_\_\_\_\_, 1983. *The genus Psilocybe*. J. Cramer, Lichtenstein.
- \_\_\_\_\_, V. M. Bandala, & L. Montoya, 1991. A comparative study of telemorphs and anamorphs of *Pleurotus cystidiosus* and *Pleurotus smithii*. *Mycological Research* 95: 1264-1269.
- \_\_\_\_\_, 1992. Personal communication.
- \_\_\_\_\_, G., L. Montoya, D. Salmones & V.M. Bandala, 1993. Studies of the genus *Pleurotus* (Basidiomycotina) II. *P. djamour* (sic) in Mexico and in other Latin-American countries, taxonomic confusions, distribution, and semi-industrial culture. *Journal of Cryptogamic Botany* 3, 213-220.
- Hammerschmidt, D.E. 1980. Szechwan Purpura. *New England Journal of Medicine* 302:P 1191-1193.
- Hardenburg, R.E., A.E. Watada, & C.Y. Wang, 1993. *The commercial storage of fruits, vegetables, and florist and nursery stocks*. U.S.D.A., Government Printing Office, Washington, D.C.
- Harris, B., 1976. *Growing wild mushrooms*. Wingbow Press, Berkeley.
- \_\_\_\_\_, 1986. *Growing Shiitake commercially*. Science Tech Publishers, Madison.
- Heim, R. & R. G. Wasson, 1958. *Les champignons hallucinogènes du Mexique*. Editions du Museum National D'Histoire Naturelle, Extrait des Archives. Paris.
- Heim, R. & R. Cailleux, R.G. Wasson & P. Thevenard, 1967. *Nouvelles investigations sur les champignons hallucinogènes*. Editions du Museum National D'Histoire Naturelle, Extrait des Archives. Paris.
- Hengshan, C. et al., 1991. Log cultivation of *Ganoderma lucidum*. *Edible Fungi of China*, vol. 10 (2): 29-32.
- Hibbett, D.S. & R. Vilgalys, 1991. Evolutionary relationships of *Lentinus* to the Polyporaceae: Evidence from restriction analyses of enzymatically amplified ribosomal DNA. *Mycologia* 83(4), pp. 425-439.

- Hilber, O. 1982. Die Gattung *Pleurotus* (Fr.) Kummer. *Bibliotheca Mycologica* 87. J. Cramer, Vaduz.
- \_\_\_\_\_. 1989. Valid, invalid, and confusion taxa of the genus *Pleurotus*. *Mushroom Science XII* (Part II). *Proceedings of the Twelfth International Congress on the Science and Cultivation of Edible Fungi* Braunschweig, Germany.
- Hishida, I, H. Nanba, & H. Kuroda, 1988. Antitumor activity exhibited by orally administered extract from fruitbodies of *Grifola frondosa* (maitake). *Chem. Pharm. Bull.* 36(5):819-1827.
- Hirofani, M., T. Furuya, & M. Shiro, 1985. A ganoderic acid derivative, a highly oxygenated lanostrene-type triterpenoid from *Ganoderma lucidum*. *Phytochemistry*, Vol. 24, No. 9, pp. 2055-2061.
- Ho, M.S., 1971. Straw mushroom cultivation in plastic house. *Proceedings from the VIIIth International Congress on Mushroom Science*, pp. 257-263. London.
- Hobbs, C., 1995. *Medicinal mushrooms: an exploration of tradition, healing & culture*. Botanica Press, Santa Cruz.
- Houdeau, G. & J.M. Olivier, 1992. *Pathology of cultivated mushrooms*. OK Press, Bologna, Italy.
- Hseu, R.S. & H.H. Wang, 1991. A new system for identifying cultures of *Ganoderma* species. *Science and Cultivation of edible fungi*, ed. Maher. *Balkema*, Rotterdam.
- Huguang, D. 1992. High yield and quality cultivation of *Hericium erinaceus* under new technology. *Edible Fungi of China*, Vol: II, No. 4: 40-43; No. 5: 29-30.
- Ikekawa, 1990. Personal communication to Paul Stamets and Andrew Weil.
- Ikekawa, j., Nakamishi, M., Uehara, N., Charara, G. and Fukuoka, F., 1968. Antitumor action of some basidiomycetes, especially *Phellinus linteus*. *Gann.* 59:155-157.
- Imazeki, R. 1937. Reishi and *Ganoderma lucidum* that grow in Europe and America: their differences. *Botany & Zoology May*, Vol. 5, No. 5.
- \_\_\_\_\_. 1943. Genera of polyporaceae of Nippon. *Bull. Tokyo Sci. Mus.* 6:1-111.
- \_\_\_\_\_. 1973. Japanese mushroom names. *The Transactions of the Asiatic Society of Japan*. Third Series, Vol. XI, Tokyo.
- Imazeki, R., Y. Otani, & N. Mizuno, 1988. *Fungi of Japan*. Yama- Kei Publishers, Tokyo.
- Imbernon, M. & J. Labarere, 1989. Selection of sporeless or poorly spored induced mutants from *Pleurotus ostreatus* and *Pleurotus pulmonarius* and selective breeding. Vol. I:109-123. *Mushroom Science XII*.
- Imbernon, M. & G. Houdeau, 1991. *Pleurotus pulmonarius* 3300 INRA-Somycel: A new poorly spore producing strain. *Science and Cultivation of Edible Fungi*, Maher (ed.), pp. 555-559. *Balkema*, Rotterdam.
- Ingle, S. 1988. Mycotopia: Paul Stamets, visionary, is perfecting the art of mushroom cultivation. *Harrowsmith Magazine* May/June, Vol. III, No. 15: 68-73.
- Ishikawa, H. 1967. Physiological and ecological studies on the *Lentinus edodes* (Berk.) Sing. *J. Agri. Lab. (Abiko)* Japan (8) 1-57.

- Ito, T. 1978. Cultivation of *Lentinus edodes* in *The Biology and Cultivation of Edible Mushrooms*, ed. by S.T. Hayes & W.A. Hayes. Academic Press, New York., pp. 461-473.
- Jianjung, Z., 1991. Bottle cultivation techniques of *Auricularia auricula* with straw won the Golden Medal in Thailand (sic). *Edible Fungi of China*, No. 10 (2): 48.
- Jifeng, W., Z. Jiajun & C. Wenwei, 1985. Study of the action of *Ganoderma lucidum* on scavenging hydroxyl radical from plasma. *Journal of Traditional Chinese Medicine* 5(1): 55- 60.
- Jinxia, Z. & S.T. Chang, 1992 Study on productivity and quality of *Volvariella volvacea* (Bull. ex. Fr.) Sing. stock culture after storage. *Edible Fungi of China* vol. 11: No.4, 3-9.
- Jones, K. 1992. *Reishi, ancient herb for modern times*. Sylvan Press, Issaquah, Washington.
- \_\_\_\_\_. 1995. *Shiitake: the healing mushrooms*. Healing Arts Press, Rochester, New York.
- Jong, S.C. & J.T. Peng, 1975. Identity and cultivation of a new commercial mushroom in Taiwan. *Mycologia* 67: 1235- 1238.
- Jong, S.C., 1989. Commercial cultivation of the Shiitake mushroom on supplemented sawdust. *Mushroom Journal of the Tropics* (9), 89-90.
- Jong, S.C., J.M. Birmingham, and S.H. Pai 1991. Immuno-modulatory substances of fungal origin. *Journal of Immunol. Immunopharmacol.* Vol. XI, N. 3.
- \_\_\_\_\_. 1992-3. Personal communications.
- Jung-lieh, Chang, 1983. Experimental study of antitumor effect of an extract derived from Zhu-Ling (*Polyprous umbellatus*). Institute of Material Medica, Academy of Traditional Chinese Medicine, Peking, China.
- Kabir, Y.M. & S. Kimura, 1987. Effect of shiitake (*Lentinus edodes*) and maitake (*Grifola frondosa*) mushrooms on blood pressure and plasma lipids of spontaneously hypertensive rats. *J. Nutr. Sci. Vitaminol.* 33:341-346.
- Kalberer, P.P., 1974. The cultivation of *Pleurotus ostreatus*: Experiments to elucidate the influence of different culture conditions on the crop yield. *Mushroom Science* IX: 653-662.
- Kawaano, et al., 1990. Novel strains of *Lyophyllum ulmarium* (sic). United States Patent 4,940,837. U.S. Patent Office, Washington, D.C.
- Kawagishi, H. 1994. Eninacines A, B & C, strong stimulators of nerve growth factor synthesis, from the mycelia of *Hericium erinaceum*. *Tetrahedron Letters* 25\* (10): 1569-1572.
- Kay, E. & R. Vilgalys, 1992. Spatial distribution and genetic relationships among individuals in a natural population of the oyster mushroom, *Pleurotus ostreatus*. *Mycologia* 84 (2): 173-182.
- Kerrigan, R. 1982. *Is shiitake farming for you?* Far West Fungi, South San Francisco.
- Khan, S.M., J. H. Mirza & M. A.. Khan, 1991 Physiology and cultivation of wood's ear mushroom *Auricularia polytricha* (Mont.) Sacc. *Mushroom Science* XII: 503-508.

- Kim, B.K., H.W. Kim & E.C. Choi, 1994. Anti-HIV effects of *Ganoderma lucidum*. *Ganoderma: Systematics, Phytopathology & Pharmacology. Proceedings of Contributed Symposium 59A,B at the 5th International Mycological Congress, Vancouver, Canada, August 14-21*, pg. 115. (Short Communication)
- Komatsu, M., Y. Nozaki, A. Inoue, & M. Miyauchi, 1980. Correlation between temporal changes in moisture contents of the wood after felling and mycelial growth of *Lentinus edodes* (Berk.) Sing. *Report of the Tottori Mycological Institute* 18: 169-187.
- Komatusu, M. & K. Tokimoto, 1982. Effects of incubation temperature and moisture content of bed logs on primordium formation of *Lentinus edodes* (Berk.) Sing. *Report of the Tottori Mycological Institute* 20: 104-112.
- Kozak, M & J. Krawczyk, 1989. *Growing shiitake mushrooms in a continental climate*. Field & Forest Products, Peshtigo, Wisconsin.
- Kuck, U., H.D. Osiewacz, U. Schmidt, B. Kappelhoff, E. Schulte, U. Stahl & K. Esser, 1985. The onset of senescence is affected by DNA rearrangements of a discontinuous mitochondrial gene in *Podospora anserina*. *Current Genetics* 9:373-382.
- Kuo, D.D & M.H. Kuo, 1983. *How to grow forest mushroom (sic) (Shiitake)*. Mushroom Technology Corp., Naperville, Il.
- Kroeger, P., 1993. Personal communication.
- Kruger, E. 1992. A new status for the lowly ironwood. *Shiitake News* (9): 2.
- Ladanyi, A., J. Timar & K. Lapis, 1993. Effect of lentinan on macrophage cytotoxicity against metastatic tumor cells. *Journal of Cancer Immunology and Immunotherapy* 36: 123-126.
- Leatham, G. 1992. Personal communication.
- \_\_\_\_\_. 1982. Cultivation of Shiitake, the Japanese forest mushroom, on logs: a potential industry for the United States. *Forest Products Journal* 332: 29-35.
- \_\_\_\_\_. & T.J. Griffin, 1984. Adapting liquid spawn of *Lentinus edodes* to oak wood. *Applied Microbiology and Biotechnology* 20: 360-364.
- \_\_\_\_\_. & M.A. Stahlman, 1987. Effect of light and aeration on fruiting of *Lentinus edodes*. *Transactions of the British Mycological Society* 88, 9-20.
- \_\_\_\_\_. 1989. The effects of common nutritionally-important cations on the growth and development of the cultivated mushroom *Lentinula edodes*. *Mushroom Science XII*: 253-265.
- Leck, Charles. 1991. Mass extinction of European fungi. *Trends in Ecology and Evolution*. Vol. 6, No. 6, June.
- Leonard, T.J. & T.J. Volk, 1992. Production of Specialty Mushrooms in North America: Shiitake & Morels. *Frontiers in Industrial Mycology*, Chapman Hall, New York.
- Li, S. and G. Eger, 1978. Characteristics of some *Pleurotus* strains from Florida, their practical and taxonomic importance. *Mushroom Science X*: 155-169.
- Li, Y.Y., L. Wang, Q.Y. Jia, J. Li, & Y. Wu, 1988. A study on the cultivation of straw mushrooms with

- wheat straw. *Mushroom Journal of the Tropics* (8): 67-72.
- Lincoff, G. & D.H. Mitchel, 1977. *Toxic and hallucinogenic mushroom poisoning: a handbook for physicians and mushroom hunters*. Van Nostrand Reinhold, New York.
- Lincoff, G., 1981. *The audubon society field guide to north american mushrooms*. Knopf, New York.
- \_\_\_\_\_. 1990-93. Personal communications.
- Lomax, K.M., 1990. Heat transfer for fresh-market mushrooms. *Shiitake News* vol. 7:2.
- Lonik, L., 1984. *The curious morel: mushroom hunter's recipes, lore & advice*. RKT Publishers, Royal Oak, Michigan.
- Maher, M.J. 1991. *Mushroom Science XIII: Science & Cultivation of Edible Fungi*. vol. I & II. A.A. Balkema, Rotterdam, Netherlands.
- Martinez, D., G. Guzman, C. Soto, 1985. The effect of fermentation of coffee pulp in the cultivation of *Pleurotus ostreatus* in Mexico. *Mushroom Newsletter for the Tropics*, (6):1, pp.21-28.
- Martinez-Carrera, D. 1987. Design of a mushroom farm for growing *Pleurotus* on coffee pulp. *Mushroom Journal of the Tropics* (7), 13-23.
- Matsumoto II, Kosai 1979. *The mysterious reishi mushroom*. Woodbridge Press Publishing Co., Santa Barbara.
- McKenna, T. 1993. Transcendental communication.
- McKenny, M., D. Stuntz, & J. Ammirati. *The new savory wild mushroom*. University of Washington Press.
- McKnight, K.B., 1985. The adaptive morphology of *Flammulina velutipes* with respect to water stress. Ph D. Thesis. University Microfilms, Ann Arbor, Michigan.
- McKnight, K.B. 1990. Effect of low humidity on spore production and basidiocarp longevity among selected isolates of *Flammulina velutipes*. *Mycologia* 82: 379- 384.
- \_\_\_\_\_. 1992. Evolution of the *Flammulina velutipes* basidiocarp size with respect to relative humidity. *Mycologia* 84(2), p. 219-228.
- McKnight, K.B. and G.F. Estabrook, 1990. Adaptations of sporocarps of the basidiomycete *Flammulina velutipes* (Agaricales) to lower humidity. *Bot. Gas. (Crawfordsville)* 151: 528-537.
- Miles, P.G. & S.T. Chang, 1986. Application of biotechnology in strain development of edible mushrooms. *Asian Food Journal* 2(1):3-10.
- Miller, O.K., 1969. A new species of *Pleurotus* with a coremoid imperfect stage. *Mycologia* 61:887-893.
- \_\_\_\_\_. 1977. *Mushrooms of north america*. E.P. Dutton, New York.
- Miller, M.W. & S.C. Jong, 1986. Commercial cultivation of shiitake in sawdust filled plastic bags. Proceedings of the International Symposium on Scientific and Technical Aspects of Cultivating Edible Fungi. July, University Park, Pa. *Elsevier Science Publishers*: 421-426.

- Mimura, S., 1904. Notes on "Shiitake" culture. *Journal of the Forestry Society of Japan*, Vol. 4. Tokyo.
- \_\_\_\_\_. 1915. Notes on "Shiitake" (*Cortinellus Shiitake* Schrot) culture. *Bulletin of the Forest Experiment Station*, Meguro, Tokyo.
- Miyasaki, T., 1983. Antitumor activity of fungal crude drugs. *Journal of Traditional Sino-Japanese Medicine* 4(1), 61-65.
- Mollison, B., 1990. *Permaculture: a practical guide for a sustainable future*. Island Press, Washington, D.C.
- \_\_\_\_\_. 1993. *The permaculture book of ferment and human nutrition*, Tagari Publications, Tyalgum, Australia.
- Morales, P., D. Martinez-Carrera, W. Martinez-Sanchez, 1991. Cultivo de Shiitake sobre diversos substratos en Mexico. *Micologia Neotropical Aplicada* 4: 75-81.
- Mori, K. 1974. *Mushrooms as health foods*. Japan Publications, Tokyo.
- Mori, K., T. Toyomasu, H. Nanba, and H. Kuroda, 1987. Antitumor activity of fruitbodies of edible mushrooms orally administered to mice. *Mushroom Journal of the Tropics* 7: 121-126.
- Morigawa, A., K. Kitabatake, Y. Fujimoto, & N. Ikekawa, 1986. Angiotensin converting enzyme-inhibitory triterpenes from *Ganoderma lucidum*. *Chemical and Pharmaceutical Bulletin* 34 (7): 3025-3028.
- Moser, M. 1978. *Keys to Agarics and Boleti*. Roger Phillips, London.
- Motohashi, T., 1993. Personal communication.
- Mueller, J.C., J.R. Gawley, 1983. Cultivation of phoenix mushrooms on pulp mill sludges. *Mushroom Newsletter for the Tropics* 4(1):3-12.
- Mueller, J.C., J.R. Gawley, & W. A. Hayes, 1985. Cultivation of the Shaggy Mane Mushroom (*Coprinus comatus*) on cellulosic residues from pulp mills. *Mushroom Newsletter for the Tropics* (6)1: 15-20.
- Murr, D.P. and L. Morris, 1975. Effects of storage temperature on post-harvest changes in mushrooms. *Journal of American Society of Horticultural Science* 100: 16-19.
- \_\_\_\_\_. 1975. Effects of storage atmosphere on post-harvest growth of mushrooms. *Journal of American Society of Horticultural Science* 100: 298-301.
- Nair, L. N. and V.P. Kaul, 1980. The anamorphs of *Pleurotus sajor-caju* (Fr.) Singer and *Pleurotus gemmellarii* (Inzeng.) Sacc. *Sydowia* 33: 221-224.
- Nanba, H. 1992. Maitake: The king of mushrooms. *Explore* 3(5) pp. 44-46.
- Nagasawa, E. and I. Arita, 1988. A note on *Hypsizygos ulmarius* and *H. marmoreus*. *Rept. Tattori Myc. Inst.* 26: 71-78.
- Nishitoba, T., H. Sato, T. Kasai, H. Kawagishi, & S. Sakamura, 1984. New bitter C27 and C30 Terpenoids from the fungus, *Ganoderma lucidum* (Reishi). *Agric. Biol. Chem.* 48(11), 2905-2907.
- Oei, P. 1991. *La culture des champignons*. Tool, Amsterdam.
-



- \_\_\_\_\_. 1991. *Manual on mushroom cultivation*. Tool, Amsterdam
- Ohno, N., K. Iino, T. Takeyama, I. Suzuki, K. Sato, S. Oikawa, T. Miyazaki, & T. Yadomae, 1985. Structural characterization and antitumor activity of the extracts from matted mycelium of cultured *Grifola frondosa*. *Chem. Pharm. Bull.* 33(8) 3395-3401.
- Okhuoya, J.A. and C.Ajerio, 1988. Analysis of sclerotia and sporophores of *Pleurotus tuber-regium* Fr. an edible mushroom in Nigeria. *Kor. J. Mycol.* Vol. 6: 4, 204-206.
- \_\_\_\_\_. 1988. Sporocarp development of *Pleurotus tuber-regium* Fr. under different watering systems. *Kor. J. Mycol.* Vol. 16: 4, 207-209.
- \_\_\_\_\_. J.A. and F.O. Okogbo, 1991. Cultivation of *Pleurotus tuber-regium* (Fr.) Sing. on various farm wastes. *Proc. Okla. Sci.* 71:1-3.
- Okwujiako, I.A., 1990. The effect of vitamins on the vegetative growth and fruitbody formation of *Pleurotus sajor-caju* (Fr.) Singer. *Mushroom Journal of the Tropics* (10): 35-39.
- Omoanghe, S., 1992. Studies on the cultivation of edible sclerotia of *Pleurotus tuber-regium* (Fr.) Sing. on various farm wastes. Master's Thesis, University of Benin, Benin City, Nigeria.
- Oso, B.A., 1977. *Pleurotus tuber-regium* from Nigeria. *Mycologia* 69: 271-279.
- Oss, O. & E. Oeric, 1976. *Psilocybin magic mushroom grower's guide*. Arno Press, Berkeley.
- Ott, J., 1976. *Hallucinogenic plants of north america*. Wingbow Press, Berkeley.
- \_\_\_\_\_. 1978. Mr. Jonathan Ott's rejoinder to Dr. Alexander Smith. *Ethnomycological Studies No. 6*. Botanical Museum of Harvard University, Cambridge.
- \_\_\_\_\_. 1993. *Pharmacotheon: entheogenic drugs, their plants and history*. Natural Products Co., Kennewick, WA.
- Ott, J. & J. Bigwood, ed. 1978. *Teonanacatl: Hallucinogenic mushrooms of north america: abstracts from the second international conference on hallucinogenic mushrooms Oct.27-30, 1977*. Madrona Publishers, Seattle.
- Ower, R. 1981-2. Personal communications.
- \_\_\_\_\_. 1982. Notes on the development of the Morel ascocarp: *Morchella esculenta*. *Mycologia* 74:142-144.
- Ower, R., G. Mills, & J. Malachowski, 1986. Cultivation of *Morchella*. *U.S. Patent No.* 4,594,809.
- \_\_\_\_\_. 1988. Cultivation of *Morchella*. *U.S. Patent No.* 4,757,640.
- Pegler, D., 1975. The classification of the genus *Lentinus* Fr. (Basidiomycota) *Kavaka* 3:11-20
- \_\_\_\_\_. 1983. *The genus Lentinus, a world monograph*. Kew Bulletin Additional Series X, London.
- \_\_\_\_\_. 1983. The genus *Lentinula* (Tricholomataceae tribe Collybiaeae). *Sydowia* 36:227-239.
- Petersen, R., 1992. Neohaploidization and neohaplont mating as a means of identification of *Pleurotus* cultures. *Mycosystema* 5: 165-170.
- Petersen, R. & K.W. Hughes, 1992. Intercontinental, interbreeding collections of *Pleurotus pulmonarius*, with notes on other species. *Sydowia*. (In Press).

- \_\_\_\_\_. 1993. Personal communication.
- Platt, M., I. Chet, & Y. Henis, 1982. Growth of *Pleurotus ostreatus* on cotton straw. *Mushroom Journal* 20: 425-426.
- Pollock, S.H., 1977. *Magic mushroom cultivation*. Herbal Medicine Research Foundation, San Antonio.
- Prance, G.T., 1984. The use of edible fungi by Amazonian indians. *Advances in Economic Botany* 1: 127-139.
- Przybylowicz, P. & J. Donoghue, 1989. *Shiitake grower's handbook: the art and science of mushroom cultivation*. Kendall Hunt, Dubuque, Iowa.
- Qingtian, Z. et al., 1991. Antitumor activity of *Flammulina velutipes* polysaccharide (FVP). *Edible Fungi of China* Vol.10, No. 2:11-15.
- Raaska, L., 1990. Production of *Lentinula edodes* mycelia in liquid media: improvement of mycelial growth by medium modification. *Mushroom Journal of the Tropics* (10), 79-92.
- Rai, R.D., S. Saxena, R.C. Upadhyay, & H.S. Sohi, 1988. Comparative nutritional value of various *Pleurotus* species grown under identical conditions. *Mushroom Journal of the Tropics* (8): 93-98.
- Rathke, D.M., & M.J. Baughman, 1993. Can shiitake production be profitable? *Shiitake News* 10:1 pp. 1-10.
- Rayner, A. 1988. Life in a collective. *New Scientist*, pp. 49-53.
- Redhead, S. 1984. Mycological observations 13-14: on *Hypsizygus* and *Tricholoma*. *Trans. Myco. Soc. Japan* 25:1-9.
- \_\_\_\_\_. & J.H. Ginns, 1985. A reappraisal of agaric genera associated with brown rots of wood. *Trans. Myco. Soc. Japan* 26: 349-381.
- \_\_\_\_\_. 1986. Mycological observations 15-16: on *Omphalina* and *Pleurotus*. *Mycologia* 78(4), pp. 522-528.
- \_\_\_\_\_. 1992-93. Personal communications.
- Reshef, A., I. Moulalem, & P. Weiner. Acute and long-term effect of exposure to basidiomycetes spores to mushroom growers. *Journal of Aller. Clin. Immunol.* 81(1) 275.
- Rice, M.C., 1980. *Mushrooms for color*. Mad River Press, Eureka.
- Roberts, T. 1988. Review of Financial analysis of three hypothetical, small scale Shiitake mushroom production enterprises. L.F. Lambert Spawn Co., Coatesville, Pa.
- Robinson, W., 1885. *Mushroom culture: its extension & improvement*. David McKay, Philadelphia.
- Romaine, C.P. and B. Schlagnhauser 1992. Characteristics of a hydrated, alginate-based delivery system for the cultivation of the button mushroom. *Applied and Environmental Microbiology*, pp. 3060-3066.
- Roxon, J.E. & S.C. Jong, 1977. Sexuality of an edible mushroom, *Pleurotus sajor-caju*. *Mycologia* LXIX (1): 203-205.

- Royse, D.J. 1985. Effect of spawn run time and substrate nutrition on yield and size of the Shiitake mushroom. *Mycologia* 77: 756-762.
- \_\_\_\_\_, L.C. Schisler, D.A. Diehle, 1985. Shiitake mushrooms: consumption, production, and cultivation. *Interdisciplinary Science Reviews* 10(4):329-335.
- \_\_\_\_\_ & C.C. Bahler, 1986. Effects of genotype, spawn run time, and substrate formulation on biological efficiency of Shiitake. *Applied and Environmental Microbiology* 52: 1425-1427.
- \_\_\_\_\_ and L.C. Schisler, 1987a. Yield and size of *Pleurotus ostreatus* and *Pleurotus sajor-caju* as affected by delayed-release nutrient. *Applied Microbiology and Biotechnology* 26: 191-194.
- \_\_\_\_\_ 1987b. Influence of benomyl on yield response of *Pleurotus sajor-caju* to delayed release nutrient supplementation. *HortScience* (22): 60-62.
- \_\_\_\_\_ and B.D. Bahler, 1988. The effect of alfalfa hay and delayed release nutrient on biological efficiency of *Pleurotus sajor-caju*. *Mushroom Journal of the Tropics* (8): 59-65.
- \_\_\_\_\_ 1989. Yield and size of Shiitake as influenced by synthetic log diameter and genotype. *Mushroom Journal for the Tropics* (9): 109-113.
- \_\_\_\_\_ B.D. Bahler, & C.C. Bahler. 1990. Enhanced yield of Shiitake by saccaride amendment of the synthetic substrate. *Journal of Applied Environmental Microbiology*. Feb., pp. 479-482.
- \_\_\_\_\_ 1991. Yield stimulation of *Pleurotus flabellatus* by dual nutrient supplementation of pasteurized wheat straw. *Science and Cultivation of Edible Fungi*, Maher (ed.), Blakema, Rotterdam.
- \_\_\_\_\_ & S.A. Zaki, 1991. Yield stimulation of *Pleurotus flabellatus* by dual nutrient supplementation of pasteurized wheat straw. *Science and Cultivation of Edible Fungi*, Maher (ed.), pp. 545-547.
- Samajpati, N., 1979. Nutritive value of some Indian edible mushrooms. *Mushroom Science X* (Part II): 695-703.
- SanAntonio, J.P., 1971. A laboratory method to obtain fruit from cased grain spawn of the cultivated mushroom *Agaricus bisporus*. *Mycologia* 63: 16-21.
- \_\_\_\_\_ 1981. Cultivation of the Shiitake mushroom. *HortScience* 16 (2): 151-156.
- \_\_\_\_\_ 1984. Using Basidiospores of the Oyster mushroom to prepare grain spawn for mushroom cultivation. *HortScience* 19 (5), pp. 684-686.
- \_\_\_\_\_ & P.K. Hanners, 1983. Spawn disk inoculation of logs to produce mushrooms. *HortScience* 18 (5): 708-710.
- \_\_\_\_\_, F.B. Abeles, & P.K. Hanners, 1989. Shiitake mushroom production on oak logs inoculated with grain-spawn disks by 23 different Shiitake strains. *Mushroom Journal of the Tropics* 9: 161-164.
- Sanderson, R. 1969. *Some field and laboratory observations on Morchella*. Master's Thesis, South Dakota State University.
- Sato, H., T. Nishitoba, S. Shirasu, K. Oda & S. Sakamura, 1986. Ganoderiol A & B, new triterpenoids from the fungus *Ganoderma lucidum* (Reishi). *Agric. Biol. Chem.* 50 (11), 2887-2890.
- Schenck, N.C. 1982. *Methods and principles of rycorrhizal research*. The American Phytopathological Society. St. Paul, Minnesota.

Sharma, A.D. and C.L. Jandalk., 1985. Studies on recycling *Pleurotus* waste. *Mushroom Journal of the Tropics*, (6)2, pp. 13-15.

Shirota, M., 1993. Personal communications.

Singer, R. & A.H. Smith, 1958. New species of *Psilocybe*. *Mycologia* 50: 141-142.

\_\_\_\_\_. 1958. Mycological investigations on *Teonanacatl*, the Mexican hallucinogenic mushroom. Part I: The history of *Teonanacatl*, field work and culture work. Part II: A taxonomic monograph on *Psilocybe*, section *Caerulescentes*. *Mycologia* 50:239-303.

Singer, R. 1961. *Mushrooms & truffles: botany, cultivation and utilization.*, Interscience Publishers, New York.

\_\_\_\_\_. 1986. *The agaricales in modern taxonomy*. 4th ed. Koeltz Scientific Books, FDR.

Smith, A.H., 1959. *Mushrooms in their natural habitats*. Hafner Press, New York.

\_\_\_\_\_. 1977. Comments on hallucinogenic agarics and the hallucinations of those who study them. *Mycologia* 69:1196-1200.

\_\_\_\_\_. 1979. Notes on the Strophariaceae. *Taxon* 28:19-21.

\_\_\_\_\_. 1977-82. Personal communications.

Snell, W.H. & Dick, E.A., 1971. *A glossary of mycology*. Harvard University Press, Cambridge.

Stamets, P., 1978. *Psilocybe mushrooms & their allies*. Homestead Book Co., Seattle.

\_\_\_\_\_. M.W. Beug, & G. Guzman, 1980. A new species and a new variety of *Psilocybe* from North America. *Mycotaxon* 11: 476-484,

\_\_\_\_\_. & Chilton, J., 1983. *The mushroom cultivator*. Agarikon Press, Olympia.

\_\_\_\_\_. A. Weil, et alia. 1983. Personal communication. Mushroom study tour of China, Fungophile, Denver.

\_\_\_\_\_. 1989. How to grow mushrooms: a simplified overview of mushroom cultivation strategies. *Shiitake News*: 6: 1, pp. 11-13.

\_\_\_\_\_. 1990. A discussion on the cultivation of *Ganoderma lucidum* (Curtis:Fr.) Kar., the Reishi or Ling Zhi, mushroom of immortality. *McIlvainea* 9 (2): 40-50.

\_\_\_\_\_. 1990. Potential uses of saprophytic fungi in the recycling of wood wastes from the forest environment. Special Forest Products Conference. Portland, Oregon.

\_\_\_\_\_. 1993. Mycofiltration of gray water run-off utilizing *Stropharia rugoso-annulata*, a white rot fungus (Unpublished Research Proposal awarded a grant by the Mason County Water Conservation District, Shelton, Washington.)

\_\_\_\_\_. 1993. Permaculture with a mycological twist. *Mushroom, the Journal* 40, vol. 11: 3. pp. 5-7.

Stavinoha, W.B., S. Weintraub, T. OPham, A. Colorado, R. Opieda, & J. Slama, 1990. Study of the anti-inflammatory activity of *Ganoderma lucidum*. *Proceedings from the Academic/Industry Conference* (AIJC), August 18-20, Sapporo, Japan.

Stickney, Larry, 1993. Personal communication.

---

- Stijve, T., 1992. Certain mushrooms do accumulate heavy metals. *Mushroom, the Journal of Wild Mushrooming* : 38: II, No. 1, p. 9-14.
- Stoller, B.b., 1962. Some practical aspects of making mushroom spawn. *Mushroom Science V*: 170-184.
- Stone, R., 1993. Surprise! A fungus factory for taxol? *Science* April, vol. 260: 9.
- Streeter, C.L., K.E. Conway, & G.W. Horn, 1981. Effect of *Pleurotus ostreatus* and *Erwinia caratovora* on wheat straw digestibility. *Mycologia*, 73 (6): 1040-1048.
- Styler, J. F., 1933. Modern mushroom culture. *Edw. H. Jacob*, West Chester, Pennsylvania.
- Tan & Chang, 1989. Yield and mycelial growth response of the Shiitake mushroom, *Lentinus edodes* (Berk.) Sing to supplementation on sawdust media. *Mushroom Journal of the Tropics*, 1989 (9): 1-14.
- Thaithatgoon, S.T. & S. Triratana, 1993. Wild, naturally grown "Reishi": cultivation, breeding, identification and their development in Thailand. In press.
- Thielke, C., 1989. Cultivation of edible fungi on coffee grounds. *Mushroom Science XII* (Part II): 337-343.
- Triratana, S., S. Thaithatgoon, & M. Gawgla. 1991. Cultivation of *Ganoderma lucidum* in sawdust bags. *Mushroom Science XII*; Science and Cultivation of Edible Fungi. A.A. Balkema, Rotterdam.
- Thorn, R.G. and G.L. Barron. 1984. Carnivorous mushrooms. *Science*, 224: 76-78.
- Tong, C. & Z. Chen, 1990. Cultivation of *Ganoderma ucidum* in Malaysia. *Mushroom Journal of the Tropics*, 10; 27-30.
- Trappe, J. 1991. Personal communication.
- Upadhyay, R.C. & B. Vijay, 1991. Cultivation of *Pleurotus* species during winter in India. *Mushroom Science XI*, Proceedings of the 13th International Congress on the Science and Cultivation of Edible Fungi. A.A. Balkema, Netherlands.
- UPI, 1988. Seattle Post Intelligencer, November 17, 1988. Seattle.
- Van de Bogart, F. 1976-1979. The genus *Coprinus* in Western North America I: *Mycotaxon* 4: 233-275; II: *Mycotaxon* 8: 243-291. III *Mycotaxon* 10: 154-174.
- Vasilov, P. B. 1955. Abriss der geographischen verbreitung der hutpilze in der Sowjetunion. Moscow-Leningrad.
- Vela, R.M. & D. Martinez-Carrera, 1989. Cultivation of *Volvariella bakeri* and *V. volvacea* in Mexico: a comparative study. *Mushroom Journal for the Tropics* (9): 99-108.
- Vilgalys, R. & M. Hester, 1990. Rapid genetic identification and mapping of enzymatically amplified ribosomal DNA from several *Cryptococcus* species. *J. Bacteriol.* 172: 4238- 4246.
- \_\_\_\_\_, A. Smith, B.L. Sun, & O.K. Miller, 1993. Intersterility groups in the *Pleurotus ostreatus* complex from the continental United States and adjacent Canada. *Canadian Journal of Botany* 71:113-128.

- \_\_\_\_\_. 1993. Personal communication.
- Volk, T.J. & T.J. Leonard, 1989. Experimental studies on the morel. I. Heterokaryon formation between monoascospore strains of *Morchella*. *Mycologia* 81(4), pp. 523-531.
- \_\_\_\_\_. 1989. Physiological and environmental studies of sclerotium formation and maturation in isolates of *Morchella crassipes*. *Applied and Environmental Microbiology*, Dec., 55: 3095-3100.
- \_\_\_\_\_. 1990. Cytology of the life-cycle of *Morchella*. *Mycological Research* 94 (3): 399-406.
- Volk, T.J., 1990. The current state of Morel cultivation. *Mushroom News* 38: 24-27.
- Volz, P.A. 1972. Nutritional studies on species and mutants of *Lepista*, *Cantharellus*, *Pleurotus* and *Volvariella*. *Mycopathol. Mycol. Appl.* 48, pp. 175-185.
- Wang, B.C., C.T. Lin, & S.C. Jong. 1990. Investigation on preservation of *Agaricus bisporus* and some other mushroom. *Mushroom Journal of the Tropics*. Vol. 10:1, pp. 1-8. The International Mushroom Society for the Tropics, Chinese University of Hong Kong.
- Wasson, R.G. & R. Heim, 1958. *Les champignons hallucinogenes du Mexique*. Editions du Museum National D'Histoire Naturelle, Extrait des Archives series 7, no., 6. Paris.
- \_\_\_\_\_. 1972. *Soma and the fly-agaric: Mr. Wasson's rejoinder to Professor Brough*. Botanical Museum of Harvard University, Cambridge.
- \_\_\_\_\_. 1973. Mushrooms and Japanese culture. *The Transactions of the Asiatic Society of Japan*. Third Series., Vol. II, Dec (1973) (April 1975), pp. 305-324.
- \_\_\_\_\_. 1976. *Soma: divine mushroom of immortality*. Harcourt, Brace & Jovanovich, New York.
- \_\_\_\_\_. 1978. *The wondrous mushroom: mycolatry in Mesoamerica*. McGraw-Hill, New York.
- \_\_\_\_\_, A. Hofmann, & C. Ruck, 1978. *The road to Eleusis: unveiling the secret of the mysteries*. Harcourt Brace Jovanovich, New York and London.
- Watling, R., 1982. Bolbitaceae: *Agrocybe*, *Bolbitious* & *Conocybe*. *British Fungus Flora* 3. Royal Botanic Garden, Edinburgh.
- Watling, R., 1984. *How to identify mushrooms to genus v: cultural and developmental features*. Mad River Press, Eureka.
- Watling, R. & N.M. Gregory, 1989. Crepidotaceae: Pleurotaceae and other pleurotoid agarics. *British Fungus Flora*. Agarics and Boleti 6. Royal Botanic Garden, Edinburgh.
- Weil, A. 1987. Recipes: a mushroom a day. *American Health Magazine* 6:4, May.
- \_\_\_\_\_. 1980-93. Personal communications.
- \_\_\_\_\_. 1980. *The marriage of the sun & the moon*. Houghton Mifflin, Boston.
- \_\_\_\_\_. 1991. *Natural health, natural medicine*. Houghton Mifflin, New York.
-

- 
- \_\_\_\_\_. 1993. Boost immunity with medicinal mushrooms. *Natural Health Magazine*, May-June, pp.12-17. New York.
- \_\_\_\_\_. 1995. *Spontaneous Healing*. Knopf, New York.
- Weir, J.R., 1917. Montana forest tree fungi- I. Polyporaceae. *Mycologia* 9: 129-137.
- Willard, T. 1990. *The Reishi Mushroom: Herb of Spiritual Potency and Medical Wonder*. Sylvan Press, Vancouver, B.C.
- Xiang, Y., 1991. A new granular structure medium for spawn manufacture and the preservation of strains. *Mushroom Science* XIII, (1): 123-124.
- Yamada, Yuko, Hioraki, Nanba, Kuroda, 1990. Antitumor effect of orally administered extracts from fruitbody of *Grifola frondosa* (Maitake). *Chemotherapy* 38: August.
- Yang Q.Y. and S.C. Jong. 1987. A quick and efficient method of making mushroom spawn. *Mushroom Science* XII, pp. 317- 324.
- Yang Q.Y. and Wang, M.M., 1994. The effect of *Ganoderma lucidum* extract against fatigue and endurance in the absence of oxygen. *Proceedings of Contributed Symposiim 59A,B at the 5th International Mycological Congress*, Vancouver, Canada, August 14-21.
- Yang Q.Y. and J.N., Fang, X.T., 1994. The isolation and identification of two polysaccharides of *Ganoderma lucidum* (GL-A, GL-B). *Proceedings of Contributed Symposiim 59A,B at the 5th International Mycological Congress*, Vancouver, Canada, August 14-21.
- Ying, Jianzhe, 1987. *Icons of medicinal fungi*. Science Press, Beijing.
- Zadrazil, F. 1976. The ecology and industrial production of *Pleurotus ostreatus*, *P. florida*, *P. cornucopiae*, and *P. eryngii*. *Mushroom Science* IX (Part I): 621-652.
- \_\_\_\_\_. 1977. The conversion of starch into feed by basidiomycetes. *European Journal of Applied Microbiology*, 4: 273.
- \_\_\_\_\_. 1980. Influence of ammonium nitrate and organic supplements on the yield of *Pleurotus sajor-caju* (Fr.) Singer. *European Journal of Applied Microbiology Biotechnology* 9: 243-248.
- \_\_\_\_\_. 1993. Personal communication.
- Zeng, Q., J. Zhao, Z. Deng, 1990. The anti-tumor activity of *Flammulina velutipes* Polysaccharide (FVP). *Edible Fungi of China*, vol. (10): 2. Szechwan Institute of Materia Medica.
- Zhao, J.D., 1989. The Ganodermataceae in China. *Bibliotheca Mycologica* 132.
- Zhuliang, Y. & Y. Chonglin, 1992. Recognition of *Hypsizgus marmoreus* (Peck) Bigelow and its cultivation. *Edible Fungi of China*, vol.II, No. 5 : 19-20.
-

## Acknowledgements

I first acknowledge the Mushrooms who have been my greatest teachers. They are the Body Intellect, the Neural Network of this book.

My family has been extremely patient and forgiving during this multi-year project. Cruz has never wavered in her belief in me and the global/spiritual significance of this book. Azureus & Ladena have tolerated my insistent need for their modeling talents and have helped on many mushroom projects.

My parents have taught me many things. My father heralded education and science and impressed upon me that a laboratory is a natural asset to every home. My mother taught me patience, kindness, and that precognition is a natural part of the human experience. My brother John first piqued my interest for mushrooms upon his return from adventures in Columbia and Mexico. Additionally, his knowledge on the scientific method of photography has greatly helped my own techniques. In some mysterious way, their combined influences set the stage for my unfolding love of fungi.

Other people warrant acknowledgement in their assistance in the completion of this book. Andrew Weil played a critical role in helping build the creative milieu, the well spring of spiritual chi from which this manuscript flowed. Gary Lincoff was extremely helpful in uncovering some of the more obscure references and waged intellectual combat with admirable skill. Brother Bill Stamets is thanked for his critical editorial remarks. Satit Thaitatgoon, my friend from Thailand, is appreciated for his insights about mushroom culture and life. I must thank Kit & Harley Barnhart for their advice on photographic technique. Michael Beug deserves acknowledgement for his unwavering support through all these years. Erik Remmen kept me healthy and strong through the many years of rigorous training in the ancient and noble martial art of Hwa Rang Do.

Joseph Ammirati, David Arora, Alan & Arleen Bessette, Janet Butz, Jonathan Caldwell, Jeff Chilton, Ken Cochran, Don Coombs, Kim & Troy Donahue, Eliza Drummond, Robert Ellingham, Gaston Guzman, Paxton Hoag, Rick Hoss, Eric Iseman, Mike Knoke, Gary Leatham, Mike Maki, Orson & Hope Miller, Scott Moore, Tomiro Motohashi, Takeshi Nakagawa, Louise North, George Osgood, Paul Paddock, Jeff Paddock, Heidi Paddock, Paul Przybylowicz, Scott Redhead, Warren Rekow, Maggie Rogers, Lynn Sabol, Bulmaro Solano, Lillian Stamets, Harry Thiers, Tom O'Dell, James Trappe, and Rytas Vilgalys all helped in their own special ways.

The late Jim Roberts, of Lambert Spawn, gained my respect and admiration for his devotion to helping the gourmet mushroom industry. And, I will never forget the generosity shown to me by the late Alexander Smith and Daniel Stuntz who were instrumental in encouraging me to continue in the field of mycology—in spite of those who fervently opposed me.

Companies which unselfishly contributed photographic or other material to this work, and to whom I am grateful, are: The Minnesota Forest Resource Center, The Growing Company, Morel Mountain, The Mori Mushroom Institute, Northwest Mycological Consultants, Organotech and Ostrom's Mushroom Farms. The Evergreen State College generously supported my studies in scanning electron microscopy and in *Psilocybe*.

Finally, I wish to acknowledge all those bewildered and bemushroomed researchers who have paved my path into the future. For your help on this odyssey through life, I will forever be in your debt.

Paul Stamets

July, 1993



## INDEX

## A

- agaricum 351  
 agarikon 351  
 agar media 90  
*Agaricus augustus* 18, 337  
   *A. bitorquis* 19, 109, 210  
   *A. brunnescens* 11, 18, 26, 109, 120, 143,  
   192, 193, 198, 204, 210, 222, 424, 429, 476  
*Agrocybe aegerita* 18, 113-115, 143, 178, 210,  
 220-223  
   *A. cylindracea* 220  
   *A. molesta* 220  
   *A. praecox* 220  
 AIDS 272, 368, 384  
 air systems 463  
*Albatrellus* 353  
 allergies 318, 354  
 alternative substrates 48, 182  
*Amanita* 1,3,23,344  
   *A. muscaria* 3  
 antibiotic media 101, 115  
 Aragekikurage 396  
*Armillaria* 32  
 Arora, D. 48, 329, 410  
 arthritis 352, 368  
 artist's conk 355  
 atmospheric sterilization 137, 171  
*Auricularia* 35, 395  
   *A. auricula* 18, 216, 396, 397, 400  
   *A. polytricha* 18, 205, 396, 397, 400  
 autoclaves 167-172

## B

- bacteria 84, 101, 137  
 bags 139-142  
 bananas 54  
 basidia 69, 71  
 Bear's Head 388  
 Beech Mushroom 248  
 Beug, M. viii,  
 biological efficiency 57-59  
 biological pasteurization 189, 190  
 bioremediation 14  
 Black Forest Mushroom 259-276  
 Black Poplar Mushroom 220  
 blood, effects upon 318, 367, 368, 378, 399  
 Brick Tops 242  
 Brooke-Webster, D. 192, 193  
 Buddha 1  
 Buna-shimeji 203, 246-253  
 Burgundy Mushroom 335  
 by-products 12, 13, 21, 41, 42, 47, 48, 56-58,  
 67, 73, 126, 146, 152, 169, 176, 181, 182, 189,  
 263, 283, 284  
 C  
 cancer 227, 234, 244, 251, 271, 281, 318, 353,  
 367, 368, 377, 378, 384, 392, 399  
 casing 209-210, 217  
 caves 470, 471  
 cereal straws 53  
 Chaga 353

Chang, S.T. 349  
Chanterelles 5-9  
cheilocystidia 73  
Chilton, J. 273  
Chinese Sclerotium 380  
Chorei-maitake 380  
clamp connections 67  
cloning 93  
coffee 54, 181, 317  
column culture 198-204  
contaminants 100, 101  
copper 6  
*Coprinus comatus* 23, 210, 224-228  
coremia 73, 112  
corncocks 54  
*Coriolus versicolor* 353  
*Costantinella cristata* 405, 411  
cropping 191-206  
culture slants 103-106  
cystidia 73  
**D**  
Dancing Mushroom 370  
decontamination mats 80, 81  
*Dendropolyporus umbellatus* 380  
designs 463, 464, 470  
DFA 90  
Dhingri Mushroom 321  
DNA 77, 283  
dog food agar 90  
donko 271

**E**

Ear Fungus 396  
Earth Maitake 380  
Elm Oyster 220  
endospores 84  
Enoki, Enokitake 229-235  
entropy 22

**F**

failure 62  
feed 56, 151, 284, 303, 318  
fermentation 348, 366  
filters 84, 462, 466  
flammulin 234  
*Flammulina velutipes* 32, 44, 106, 115, 126, 143, 152, 161, 164, 205, 206, 212, 229-235, 240, 256, 279, 427  
flax  
flies 453  
fodder 284, 303, 368  
*Fomitopsis offinalis* 352, 353  
formulas 90, 129, 162, 182  
freezing 105  
frogs 445  
fruitbody development 212, 217  
Fukuoka 41  
Fukurotake 344  
*Fuligo cristata* 23  
fungicides 132, 135  
**G**  
*Galerina* 23  
*G. autumnalis* 23, 32, 231

---

ganoderic acids 368

*Ganoderma* 353, 355

*G. applanatum* 352, 353, 356

*G. curtisii* 353, 357

*G. japonicum* 357

*G. lucidum* 32, 35, 44, 55, 113-115, 120, 123, 126, 138, 143, 152, 196, 205, 206, 210, 275, 352, 353, 355-369, 378, 421, 427

*G. oregonense* 50, 353, 356, 357

*G. sinense* 353, 357

*G. tsugae* 50, 353, 357, 359

Garden Giant Mushroom 335

*Gloephyllum* 14

glove boxes 93

Golden Mushroom 229, 285

Golden Oak Mushroom 259-275

Good Fortune Mushroom 356

grain spawn 85, 132-142

*Grifola frondosa* 370-379

*G. umbellata* 353, 380-385

grifolan 377

growing rooms 458, 459, 469, 471-480

Guzman, G. 327, 328

*Gymnopilus luteofolius* 112

*G. spectabilis* 38, 370

## H

Hedgehog 388

Heim, R. 328

Hen-of-the-Woods 370-379

*Heridium* 387

*H. abietis* 388

*H. coralloides* 387, 388

*H. erinaceus* 29, 35, 44, 109, 113-115, 120, 161, 178, 216, 387-394, 435

Hiratake 297

HIV/AIDS 271, 353, 367, 373, 384

Hog Tuber Mushroom 384

Hon-shimeji 246-253

hymenium 70

hyphal aggregates 111

*Hypholoma* 50, 236-245

*H. capnoides* 18, 23, 35, 44, 50, 109, 120, 237-241

*H. fasciculare* 23, 32, 237

*H. sublateritium* 18, 23, 35, 109, 113, 120, 152, 161, 239, 242-245

*Hypsizygus* 246

*H. marmoreus* 18, 203, 248, 252

*H. tessulatus* 18, 115, 153, 203, 205, 206, 246-253, 258, 432, 435-437

*H. ulmarius* 18, 115, 153, 206, 246-248, 252, 254-258

## I

incubation 176-178

Indian Oyster Mushroom 321

initiation 121, 213-216

inoculation

agar 93-101

bulk substrates 181-191

grain 129-142

liquid 142

sawdust 155-159

spore mass 8, 24-25, 143-146

straw 181-191

*Inonotus obliquus* 353

## K

Kikurage 396

King Stropharia 335

Kumotake 370

Kuritake 242-245

**L**

laboratory, 461-466

*Laetiporus sulphureus* 32, 44, 110, 113, 114, 353, 354

laminar flow benches 95, 96

landscaping 20-23

lentinan 271

*Lentinula* 259

*L. edodes* 11, 18, 36, 44, 107, 112, 115, 119, 120, 124-126, 130, 138, 143, 144, 152, 161, 163, 164, 173, 177, 178, 181, 182, 195, 196, 210, 215-217, 259-276, 420, 426, 427, 429, 432, 433, 435, 437-440, 479, P11-P14

*L. sajor-caju* 322

*Lentinus* 261

*Lepista nuda* 19, 113, 120

life cycle 64

light 217, 317, 318, 319

Lincoff, G. 306, 307, 384

Ling Chi, Ling Chih 45, 353, 355-369

Lion's Mane 388

liquid culture/inoculation 142, 143, 145-151

log culture 34-39, 358-359

*Lyophyllum* 246, 249, 252, 254

*L. shimeji* 246, 252

*L. ulmarius* 249, 254

**M**

Maitake 32, 34, 44, 370-379

malt extract agar 90

Mannentake 356

Maple Oyster Mushroom 292

marketing 429

Matsutake 5, 8

Mayans 367

McKenna, T. 327

MEA, MYA 90

media 90, 128, 130

megablock 206

metabolites 126

Miller, O.K. 292

Mo-er 396

Mokurage 396

molasses 391

Monkey Seat Mushroom 356

*Morchella* 29, 45, 107, 113, 119, 177, 216, 401-408, 421, 427, 434, 435, 438

*M. angusticeps* 26, 107, 111, 405, 408-418

*M. atrotomentosa* 409, 410

*M. crassipes* 404

*M. elata* 409

*M. esculenta* 407, 409, 415, 416

Mountain Echo Mushroom 248

Mountain Priest Mushroom 388

Mu-er 396

Muk Ngo 396

Mushroom of Immortality 356

mushroom life cycle 64

mushroom stones

mycelium 107-114

mycofiltration 15

mycomaniacs 543

mycopermaculture 40-46, 245, 260

mycorrhizae 5, 7

mycosphere 68

---

## N

*Naematoloma*

- N. capnoides* 237
- N. fasciculare* 237
- N. sublateritium* 242

Nameko 44, 277-283

Namerako Mushroom 279

natural culture 21, 36

nematodes 125

nutrition 125

## O

oatmeal malt yeast agar 90

OMYA 90

Ott, J. viii, 327

Ower, R. 405

*Oxyporus nobilissimus* 353

Oyster Mushrooms 283-326

## P

Paddy Straw Mushroom 343-350

Panaecea Polypore 368

paper 53

parasites 9

pasteurization 183-188

PDY, PDYA 90

peanuts 54

pelletized spawn 159

permaculture 40-46

Petersen, R.H. 313

*Phanerochaete chrysosporium* 14

Phase II 185-189

phenotype 93

*Pholiota* 276, 328

*P. aegerita* 220

*P. cylindracea* 220

*P. nameko* 35, 44, 112, 115, 119, 143, 161, 277-282

phosphorus 6

phototropism 120, 121

Pink Oyster Mushroom 297

pioppino 220

*Piptoporus betulinus* 21, 352, 353

*Pisolithus tinctorius* 8

*Pleurotus* 283, 284

*P. abalonus* 18, 111, 113, 292, 293

*P. citrinopileatus* 18, 54, 73, 74, 111, 113, 183, 283, 292-296

*P. columbinus* 314

*P. cornucopiae* 18, 258, 285

*P. cystidiosus* 18, 54, 73, 111, 113, 183, 283, 292-296

*P. djamor* 18, 54, 113-115, 143, 183, 202, 283, 297-303, 309

*P. elongatipes* 248

*P. eous* 297, 309

*P. eryngii* 143, 284, 304-308

*P. euosmus* 309-312

*P. flabellatus* 297, 300

*P. florida* 314

*P. floridanus* 314

*P. oputinae* 48

*P. ostreatoroseus* 297, 303

*P. ostreatus* 284, 313-320

*P. populinus* 321, 322

*P. pulmonarius* 143, 284, 313, 314, 321-325

*P. sajor-caju* 321-325

*P. salmoneo-stramineus* 297-303

*P. sapidus* 314

*P. tuber-regium* 66, 318, 320

*P. ulmarius* 254

plug spawn 39

poisonous 23, 24

- Pollock, S. 90  
polyculture 22, 23, 31  
Polypores 351-385  
*Polyporus* 352-355  
  *P. betulinus*  
  *P. frondosus* 370-379  
  *P. sulphureus* 32, 354  
  *P. umbellatus* 353, 380-385  
Poria cocos 404  
potato dextrose yeast agar 90  
primordia 68, 114, 208  
Przybylowicz, P. 39, 50  
psilocin 24, 327  
*Psilocybe* 45, 46, 50, 112, 327-334  
  *P. australiana* 334  
  *P. azurescens* 329, 333  
  *P. bohemica* 334  
  *P. cubensis* 18, 69, 109, 120, 204, 214  
  *P. cyanescens* 18, 23, 50, 109, 327-334  
  *P. cyanofibrillosa* 329, 332,  
  *P. mexicana* 66  
  *P. serbica* 329, 334  
  *P. subaeruginosa* 334  
  *P. tampanensis* 404  
psilocybin 327  
**R**  
refrigeration 105  
Reishi 45, 353-369  
rhizomorphs 49  
*Rhodotorula glutinis* 8  
rice bran 55  
Roberts, J. 378  
**S**  
*Saccharomyces cerevisiae* 142  
Saiwai-take 356  
Salmon Oyster Mushroom 297  
Salzman, E. 384  
San Antonio, J. 38, 50, 146  
saprophytes 5, 10  
Sarunouchitake 356  
sawdust spawn 35, 85, 155-159  
sclerotia 64, 66, 318, 380-385  
seed hulls 54  
senescence 8, 96, 106  
Senji 396  
sex 368  
Shaggy Manes 44, 224-228  
Shiitake 36, 44, 259-275  
Shimeji 246  
Shirotamogitake 246, 254  
Sinden, J. 26  
Singer, R. 328  
slants 103, 104  
Smith, A. 328  
Snow Peak Mushroom 229  
South Poplar Mushroom 220  
soybean 55  
spawn 62, 129-142  
spawn disc 38  
spawn generation 61, 127-153, 155-159  
species diversity 12  
species mosaics 22  
species sequencing 22, 44, 419-422  
spent straw 284, 303, 318  
Spiritual Mushroom 327, 356

- spore germination 100  
spore load 247, 318  
spore mass inoculation 8, 24, 25, 142-144  
spore prints 24, 96-100  
sporeless strains 283, 314  
Stametsian model 40, 41  
Stamets "P" value 106  
sterile technique 83  
sterilization 79, 133, 167-172  
stock cultures 103-106  
Stoller, B. 26, 27  
storage 124, 153, 154  
strain 62, 118  
strategies 84-87, 145, 142  
Strawberry Oyster Mushroom 297  
*Stropharia*  
  *S. rugoso-annulata* 11, 18, 22, 25, 42, 49,  
  50, 107, 109, 110, 112, 114, 119, 120, 124,  
  126, 138, 143, 183, 209, 239, 256, 284, 303,  
  335-342, 420, 421, 432, P31-P35  
  *S. ferrii* 336  
structure 56  
stumps 31, 33, 42  
substrate formulas 162-190  
sugar cane bagasse 54  
supplementation 162, 167  
super-pasteurization 137, 171  
Swordbelt Agrocybe 220  
**T**  
Tabang ngungut 297  
Takihiro Hiratake 297  
Tamogitake 313  
Tamo-motashi 248  
Tarragon Oyster Mushroom 309  
taxol 9  
Telluride 212  
thermogenesis 55, 152, 176  
toxins 13-15  
*Trametes versicolor* 353  
transplantation 24, 26  
tray culture 192  
Tree Ear 396  
Tree of Life Mushroom 356  
tree types 50-52  
trouble-shooting 443-453  
Truffles 5-7  
Tsuchi-maitake 380  
*Tuber*  
  *T. gibbosum* 6  
  *T. melanosporum* 6, 7  
**U**  
ulcers 392  
Umbrella Polypore 380  
**V**  
"V" inoculation method 35  
vectors of contamination 75  
Vilgalys, R. 313  
Volk, T. 405  
*Volvariella volvacea* 106, 119, 121, 154, 183,  
343-350, 420, 424  
**W**  
wall culture 195  
Wasson, R.G. 3, 4, 327

water, watering 213, 217

wedge inoculation 35, 38

Weil, A. 327, 353, 384, 390

wheat straw 48, 181-190

Wine Cap Mushroom 335

Wood Ear Mushroom 395-400

wood types 48-50

## Y

Yamabiko Hon-shimeji 248

Yamabushi-take 388

Yanagi-matsutake 220

yeast 55

## Z

Zadrazil, F. 58

Zi Zhi 357

Zhuzhuang-Tiantougu 220

Zhu Ling 380

zinc 6

---



## Photographic & Diagrammatic Credits

- Kristine M. Adam Figure 367  
 Rodney Barrett 181  
 Kit Scates Barnhart Figures 10, 19, 117, 177, 204  
 Alan Bessette Figures 333–335  
 Michael Beug Figure 297  
 David Bill Figures 28, 342  
 Davel Brooke-Webster Figures 154–157  
 Jeff Chilton Figure 315  
 Kandis Elliot Figure 362  
 Bill Freedman Figure 316  
 Peter Furst Figures 5–7, 397  
 Guy Gardiner Figure 321  
 Linda Greer Figures 14, 20–22, 26, 27, 31, 32, 37, 343, 381  
 Ann Gunter Figures 41, 61, 70, 119  
 Bob Harris Figures 231, 233, 234, 235, 395  
 Kathleen Harrison Figure 1  
 Jim Haseltine Figures 176, 221, 224, 252  
 Bob Johns Figures 161, 162  
 S.C. Jong Figure 268  
 Paul Lewis, Figures 322, 394  
 Gary Lincoff Figure 210, 259, 263  
 Hugues Massicotte Figures 8, 9  
 Gary Menser Figure 7  
 Orson Miller Figure 267  
 Minnesota Forest Resource Center Figures 238, 239  
 T. Motohashi Figure 216  
 Perry Muleazy Figures 364, 365  
 Takeshi Nakazawa Figures 206, 222, 287, 320, 339  
 S. Omoanghe Figure 43  
 Paul Przybylowicz Figure 237  
 Trace Salmon Figures 39, 136–138, 148, 151, 191, 369, 386–388  
 Mark Sanford Figures 62, 63, 71, 120, 121, 393  
 Ed Sliffe Figure 36  
 Cruz Stamets Figures 18, 147, 201  
 Paul Stamets Figures 2, 11, 13, 15, 17, 23, 29, 30, 34, 35, 38, 40, 42, 44–60, 64–69, 72–99, 101–114, 116, 118, 122–125, 127–135, 139–150, 152, 153, 163–175, 180, 182–190, 192–203, 205, 207–209, 211–215, 217–220, 223, 225–230, 232, 236, 240–244, 246–251, 253–258, 260–262, 264–266, 269, 270, 272–286, 288–296, 298–305, 307, 311, 317, 318, 319, 325, 326, 331, 332, 336–338, 340–342, 344–353, 355, 358, 361, 363, 366, 368, 370–376, 378–380, 382–385, 391, 392  
 Glenn Tamai Figures 159, 245  
 Satit Thaitatgoon Figures 100, 158, 160, 178, 179, 271, 306, 308, 309, 310, 312, 313, 327–330, 354, 377  
 Spencer Throckmorton Figure 8  
 Steve Vento Figure 126  
 Thomas Volk Figures 359, 360  
 F. Zadrazil Figure 33

## Color Plate Credits

- Alan Bessette Figures 52, 53  
 Julie Carris Inside Jacket  
 Lance Howell 16  
 Paul Lewis Figure 42  
 Gary Lincoff Figures 20, 21  
 Rich Lucas Figure 30  
 Takeshi Nakazawa Figures 6, 18, 46, 50  
 Paul Stamets Figures 1–5, 7–15, 19, 22–29, 31–35, 39, 43–46, 48, 49, 51, 54–58  
 Satit Thaitatgoon Figures 36–38, 40, 47





Figure 397. Ceramic sculpture depicting mycophiles dancing around a sacred mushroom from Colima, western Mexico circa 100 B.C.